

RC8 Provider for DENSO Robot RC8

Version 1.1.9

User's Guide

May 16, 2022

[Remarks]

[Revision History]

Version	Date	Content
1.1.0	2012-09-10	First edition.
1.1.1	2012-10-31	Added Hand object interface.
	2013-02-06	Motion option in CaoRobot::{Move, Rotate, Draw, Approach, Depart, DriveEx, DriveAEx, RotateH} method has been modified.
	2013-06-27	Added a postscript about @IfNotMember option.
	2013-07-09	Added description about log interface.
	2013-07-24	Added Synchronizing flag to KillAll, SuspendAll, and StepStopAll.
		Added CurJntEx, HighCurJntEx, DestJntEx, CurPosEx, HighCurPosEx, DestPosEx, CurTrnEx, HighCurTrnEx, and DestTrnEx
	2013-08-01	Added following arguments to Force Param <ul style="list-style-type: none"> • Control rate • Maximum translation speed • Maximum rotation speed Added following items <ul style="list-style-type: none"> • KillAllTsr, RunAllTsr • ForceValue • ForceWaitCondition • ForceChangeTable
	2013-12-06	Added DPS command
1.1.2	2014-02-24	Added Appendix C
	2014-03-05	Added SysInfo, RobInfo.
	2014-03-06	Added Non-Stop Motion Calculator
	2014-04-02	Added GetPublicValue and SetPublicValue
	2014-09-08	Added following items: SyncTimeStart, SyncTimeEnd, SyncMoveStart, SyncMoveEnd, SetBaseDef, GetBaseDef, SetHandIO, GetHandIO, StartServoLog, ClearServoLog, and StopServoLog
	2014-11-06	Added GetCtrlLogMaxTime, SetCtrlLogMaxTime, GetCtrlLogInterval, and SetCtrlLogInterval
1.1.3	2015-01-08	Added Event list Added Base* to the Robot class system variable Added DetectOn, DetectOff, and PluralServoData
1.1.3	2015-05-26	Added GenerateNonStopPath parameter

1.1.3	2015-07-30	Added AngularTrigger,GetCurErrorCount,GetCurErrorinfo
1.1.3	2017-04-27	Added VirtualFence, ExclusiveArea, SetExclusiveArea, ResetExclusiveArea, ExclusiveControlStatus
1.1.3	2017-04-27	Added the recovery of error to Appendix D.2. Error Codes; and did error corrections.
1.1.3	2017-05-22	Added GetAllSrvData, CurForceParam
1.1.3	2018-03-01	Modified GenerateNonStopPath command Modified Appendix D.1. Parameter
1.1.4	2018-09-18	Added GetLogCount, GetLogRecord
1.1.5	2019-02-26	Ver. 2.8.0 or higher • COBOTTA dedicated commands were added • Array access variables for variables and IO were added
1.1.5	2019-07-04	• Modified GetSrvData command return value • Modified GetSrvJntData command return value
1.1.6	2019-08-27	Ver. 2.8.0 or higher • COBOTTA Electric vacuum generator and K3 hand commands were added
1.1.6	2019-08-30	• Added lists of COBOTTA dedicated commands • Added the version information to lists of commands.
1.1.6	2020-03-06	Modified 3.1.1. Functions provided by RC8 provider
1.1.7	2020-05-18	Ver.2.11.0 or higher Added GetForceLogRecord, CurExtSpd, CurExtAcc, CurExtDec
1.1.7	2020-06-24	Added RC8A to compatible device.
1.1.7	2021-01-11	Added ManualResetPreparation for the COBOTTA-dedicated commands
1.1.7	2021-03-19	Modified GetAllSrvData command return value
1.1.8	2021-06-02	• Added system variables (@IO_ALLOC_MODE, @STATE, @ASP_MODE, @ERROR_CODE, @ERROR_DESCRIPTION, @LOCK) • Added GetDirectMode, GetMechaButtonState, and ClearMechaButtonState for the COBOTTA-dedicated commands
1.1.9	2022-01-22	Modified AddController method
	2022-05-16	Fixed typos in “5.3.3. Task class”

[Compatible device]

Model	Version	Notes
RC8		
RC8A		

[Operation check device]

Model	Version	Notes
RC8	1.2.4	

[Command]

Model	Version	Notes
RC8	1.3.6	Added Spline-related commands

Contents

1. Introduction	13
1.1. System requirements and versions assumed in this document.....	13
1.2. Information sources for your reference	13
2. Environment Setup for Application Development	15
2.1. Setup of PC development environment.....	15
2.1.1. Automatic installation of RC8 provider.....	15
2.1.2. Manual installation of RC8 provider.....	15
2.2. Setup of RC8 controller	15
2.2.1. Emergency stop device position	15
2.2.2. Preparation of hardware	15
2.2.3. Setup of system parameters.....	18
2.2.3.1. Setup using a teach pendant	19
2.2.3.2. Setup using a mini pendant.....	22
2.3. Operation check using CaoTester	26
2.3.1. Check of variable access.....	26
2.3.2. Check that the motor is ON	29
3. Basic Knowledge on RC8 Programming	32
3.1. Outline of RC8 provider	32
3.1.1. Functions provided by RC8 provider	32
3.1.2. System configuration of RC8 provider.....	33
3.1.2.1. Configuration of Cao engine and Cao provider	34
3.1.3. HRESULT and handling of errors	35
3.1.4. Handling of property definitions	35
3.1.5. Execution method and runtime binding	36
4. RC8 Programming Using the Provider	37
4.1. RC8 controller variable access.....	38
4.1.1. Connection	38
4.1.2. Variable read/write access.....	39
4.1.3. Disconnection.....	40
4.1.4. Sample program.....	41
4.2. Task control with RC8 controller.....	42
4.2.1. Connection	42
4.2.2. Start/stop of a task	42
4.2.3. Sample program.....	43
4.3. Robot control with RC8 controller.....	44
4.3.1. Connection	44

4.3.2. Getting and release of arm control authority	45
4.3.3. Start and stop of the motor.....	45
4.3.4. Move and stop of the robot	45
4.3.5. Sample program.....	45
5. Command Reference	48
5.1. List of commands.....	48
5.2. Methods and properties.....	49
5.2.1. CaoWorkspace::AddController method	49
5.2.1.1. When you establish multiple connections with RC8 controller	51
5.2.2. CaoController::AddFile method	52
5.2.3. CaoController::AddRobot method.....	53
5.2.4. CaoController::AddTask method.....	54
5.2.5. CaoController::AddVariable method	55
5.2.6. CaoController::AddExtension method	56
5.2.7. CaoController::get_Name property.....	57
5.2.8. CaoController::get_FileNames property	57
5.2.9. CaoController::get_TaskNames property	57
5.2.10. CaoController::get_VariableNames property.....	58
5.2.11. CaoController::Execute method.....	58
5.2.11.1. CaoController::Execute("ClearError") command	59
5.2.11.2. CaoController::Execute("GetErrorDescription") command	60
5.2.11.3. CaoController::Execute("KillAll") command	60
5.2.11.4. CaoController::Execute("KillAllTsr") command.....	60
5.2.11.5. CaoController::Execute("RunAllTsr") command.....	61
5.2.11.6. CaoController::Execute("SuspendAll") command.....	61
5.2.11.7. CaoController::Execute("StepStopAll") command.....	62
5.2.11.8. CaoController::Execute("ContinueStartAll") command	62
5.2.11.9. CaoController::Execute("GetErrorLogCount") command	63
5.2.11.10. CaoController::Execute("GetErrorLog") command	63
5.2.11.11. CaoController::Execute("GetOprLogCount") command.....	64
5.2.11.12. CaoController::Execute("GetOprLog") command	65
5.2.11.13. CaoController::Execute("GetPublicValue") command.....	66
5.2.11.14. CaoController::Execute("SetPublicValue") command	68
5.2.11.15. CaoController::Execute("SysState") command.....	70
5.2.11.16. CaoController::Execute("SysInfo") command	70
5.2.11.17. CaoController::Execute("SetAllDummyIO") command	72
5.2.11.18. CaoController::Execute("GetCurErrorCount") command.....	72

5.2.11.19. CaoController::Execute("GetCurErrorInfo") command	72
5.2.12. CaoController::Execute method (dedicated for COBOTTA).....	73
5.2.12.1. CaoController::Execute ("GetCCSConnection") command.....	75
5.2.12.2. CaoController::Execute("GetDirectMode") command	75
5.2.12.3. CaoController::Execute ("ManualResetPreparation") command.....	75
5.2.12.4. CaoController::Execute ("HandChuck") command	76
5.2.12.5. CaoController::Execute("HandUnChuck") command	77
5.2.12.6. CaoController::Execute("HandMoveA") command.....	77
5.2.12.7. CaoController::Execute("HandMoveR") command.....	77
5.2.12.8. CaoController::Execute("HandMoveH") command.....	78
5.2.12.9. CaoController::Execute("HandMoveAH") command	78
5.2.12.10. CaoController::Execute("HandMoveRH") command	79
5.2.12.11. CaoController::Execute("HandMoveZH") command.....	79
5.2.12.12. CaoController::Execute("HandStop") command.....	80
5.2.12.13. CaoController::Execute("HandBusyState") command.....	80
5.2.12.14. CaoController::Execute("HandHoldState") command	81
5.2.12.15. CaoController::Execute("HandInposState") command	81
5.2.12.16. CaoController::Execute("HandZonState") command.....	82
5.2.12.17. CaoController::Execute("HandCurPos") command	82
5.2.12.18. CaoController::Execute("HandMoveVH") command	82
5.2.12.19. CaoController::Execute("HandCurPressure") command.....	83
5.2.12.20. CaoController::Execute("HandCurLoad") command	83
5.2.12.21. CaoController::Execute("HandSetDetectThreshold") command.....	84
5.2.13. CaoFile::AddFile method	84
5.2.14. CaoFile::AddVariable method	84
5.2.15. CaoFile::get_VariableNames property.....	85
5.2.16. CaoFile::get_FileNames property	85
5.2.17. CaoFile::get_Size property	85
5.2.18. CaoFile::get_Value property	86
5.2.19. CaoFile::put_Value property	86
5.2.20. CaoRobot::Accelerate method.....	86
5.2.21. CaoRobot::AddVariable method	87
5.2.22. CaoRobot::get_VariableNames property.....	87
5.2.23. CaoRobot::Halt method	87
5.2.24. CaoRobot::Change method	88
5.2.25. CaoRobot::Drive method	88
5.2.26. CaoRobot::Move method.....	89

5.2.27. CaoRobot::Rotate method	92
5.2.28. CaoRobot::Speed method	94
5.2.29. CaoRobot::Execute method.....	95
5.2.29.1. CaoRobot::Execute("TMul") command.....	102
5.2.29.2. CaoRobot::Execute("TInv") command.....	102
5.2.29.3. CaoRobot::Execute("TNorm") command.....	103
5.2.29.4. CaoRobot::Execute("J2T") command.....	103
5.2.29.5. CaoRobot::Execute("T2J") command.....	104
5.2.29.6. CaoRobot::Execute("J2P") command.....	104
5.2.29.7. CaoRobot::Execute("P2J") command.....	105
5.2.29.8. CaoRobot::Execute("T2P") command	105
5.2.29.9. CaoRobot::Execute("P2T") command	106
5.2.29.10. CaoRobot::Execute("Dev") command.....	106
5.2.29.11. CaoRobot::Execute("DevH") command	107
5.2.29.12. CaoRobot::Execute("OutOfRange") command	107
5.2.29.13. CaoRobot::Execute("MPS") command	108
5.2.29.14. CaoRobot::Execute("RPM") command.....	108
5.2.29.15. CaoRobot::Execute("DPS") command.....	109
5.2.29.16. CaoRobot::Execute("CurPos") command.....	109
5.2.29.17. CaoRobot::Execute("DestPos") command	110
5.2.29.18. CaoRobot::Execute ("CurPosEx") command.....	110
5.2.29.19. CaoRobot::Execute("DestPosEx") command.....	111
5.2.29.20. CaoRobot::Execute("HighCurPosEx") command	111
5.2.29.21. CaoRobot::Execute("CurJnt") command	112
5.2.29.22. CaoRobot::Execute("DestJnt") command.....	112
5.2.29.23. CaoRobot::Execute("CurJntEx") command	113
5.2.29.24. CaoRobot::Execute("DestJntEx") command	113
5.2.29.25. CaoRobot::Execute("HighCurJntEx") command.....	114
5.2.29.26. CaoRobot::Execute("CurTrn") command.....	114
5.2.29.27. CaoRobot::Execute("DestTrn") command	115
5.2.29.28. CaoRobot::Execute("CurTrnEx") command.....	115
5.2.29.29. CaoRobot::Execute("DestTrnEx") command.....	116
5.2.29.30. CaoRobot::Execute("HighCurTrnEx") command	116
5.2.29.31. CaoRobot::Execute("CurFig") command	117
5.2.29.32. CaoRobot::Execute("CurSpd") command.....	117
5.2.29.33. CaoRobot::Execute("CurAcc") command	117
5.2.29.34. CaoRobot::Execute("CurDec") command.....	118

5.2.29.35. CaoRobot::Execute("CurJSpd") command	118
5.2.29.36. CaoRobot::Execute("CurJAcc") command	118
5.2.29.37. CaoRobot::Execute("CurJDec") command	119
5.2.29.38. CaoRobot::Execute("CurExtSpd") command.....	119
5.2.29.39. CaoRobot::Execute("CurExtAcc") command.....	119
5.2.29.40. CaoRobot::Execute("CurExtDec") command	120
5.2.29.41. CaoRobot::Execute("StartLog") command	120
5.2.29.42. CaoRobot::Execute("StopLog") command.....	120
5.2.29.43. CaoRobot::Execute("ClearLog") command	121
5.2.29.44. CaoRobot::Execute("Motor") command.....	121
5.2.29.45. CaoRobot::Execute("ExtSpeed") command	122
5.2.29.46. CaoRobot::Execute("TakeArm") command.....	122
5.2.29.47. CaoRobot::Execute("GiveArm") command.....	123
5.2.29.48. CaoRobot::Execute("Draw") command.....	124
5.2.29.49. CaoRobot::Execute("Approach") command	125
5.2.29.50. CaoRobot::Execute("Depart") command	126
5.2.29.51. CaoRobot::Execute("DriveEx") command	127
5.2.29.52. CaoRobot::Execute("DriveAEx") command.....	128
5.2.29.53. CaoRobot::Execute("RotateH") command.....	129
5.2.29.54. CaoRobot::Execute("Arrive") command.....	129
5.2.29.55. CaoRobot::Execute("MotionSkip") command	130
5.2.29.56. CaoRobot::Execute("MotionComplete") command.....	130
5.2.29.57. CaoRobot::Execute("CurTool") command	131
5.2.29.58. CaoRobot::Execute("GetToolDef") command.....	131
5.2.29.59. CaoRobot::Execute("SetToolDef") command	132
5.2.29.60. CaoRobot::Execute("CurWork") command.....	132
5.2.29.61. CaoRobot::Execute("GetWorkDef") command	132
5.2.29.62. CaoRobot::Execute("SetWorkDef") command	133
5.2.29.63. CaoRobot::Execute("WorkAttribute") command	133
5.2.29.64. CaoRobot::Execute("GetAreaDef") command.....	134
5.2.29.65. CaoRobot::Execute("SetAreaDef") command	134
5.2.29.66. CaoRobot::Execute("SetArea") command.....	135
5.2.29.67. CaoRobot::Execute("ResetArea") command.....	135
5.2.29.68. CaoRobot::Execute("AreaSize") command	136
5.2.29.69. CaoRobot::Execute("GetAreaEnabled") command	136
5.2.29.70. CaoRobot::Execute("SetAreaEnabled") command.....	136
5.2.29.71. CaoRobot::Execute("AddPathPoint") command.....	137

5.2.29.72. CaoRobot::Execute("ClrPathPoint") command.....	137
5.2.29.73. CaoRobot::Execute("GetPathPoint") command	138
5.2.29.74. CaoRobot::Execute("LoadPathPoint") command	138
5.2.29.75. CaoRobot::Execute("GetPathPointCount ") command.....	139
5.2.29.76. CaoRobot::Execute("GetRobotTypeName") command.....	139
5.2.29.77. CaoRobot::Execute("ArchMove") command.....	140
5.2.29.78. CaoRobot::Execute("CrtMotionAllow") command.....	140
5.2.29.79. CaoRobot::Execute("EncMotionAllow") command	141
5.2.29.80. CaoRobot::Execute("EncMotionAllowJnt") command	141
5.2.29.81. CaoRobot::Execute("ErAlw") command.....	142
5.2.29.82. CaoRobot::Execute("ForceCtrl") command	142
5.2.29.83. CaoRobot::Execute("ForceParam") command	143
5.2.29.84. CaoRobot::Execute("ForceValue") command.....	144
5.2.29.85. CaoRobot::Execute("ForceWaitCondition") command	145
5.2.29.86. CaoRobot::Execute("ForceSensor") command	146
5.2.29.87. CaoRobot::Execute("ForceChangeTable") command	146
5.2.29.88. CaoRobot::Execute("GetSrvData") command	147
5.2.29.89. CaoRobot::Execute("GetSrvJntData") command	147
5.2.29.90. CaoRobot::Execute("GrvCtrl") command.....	148
5.2.29.91. CaoRobot::Execute("CurLmt") command	148
5.2.29.92. CaoRobot::Execute("Zforce") command.....	149
5.2.29.93. CaoRobot::Execute("GrvOffset") command.....	149
5.2.29.94. CaoRobot::Execute("HighPathAccuracy") command	150
5.2.29.95. CaoRobot::Execute("MotionTimeout") command	150
5.2.29.96. CaoRobot::Execute("SingularAvoid") command.....	151
5.2.29.97. CaoRobot::Execute("SpeedMode") command.....	151
5.2.29.98. CaoRobot::Execute("PayLoad") command.....	152
5.2.29.99. CaoRobot::Execute("GenerateNonStopPath ") command	152
5.2.29.100. CaoRobot::Execute("RobInfo") command	153
5.2.29.101. CaoRobot::Execute("SyncTimeStart") command	153
5.2.29.102. CaoRobot::Execute("SyncTimeEnd") command	154
5.2.29.103. CaoRobot::Execute("SyncMoveStart") command.....	154
5.2.29.104. CaoRobot::Execute("SyncMoveEnd") command.....	155
5.2.29.105. CaoRobot::Execute("SetBaseDef") command.....	155
5.2.29.106. CaoRobot::Execute("GetBaseDef") command	156
5.2.29.107. CaoRobot::Execute("SetHandIO") command	156
5.2.29.108. CaoRobot::Execute("GetHandIO") command.....	156

5.2.29.109. CaoRobot::Execute("StartServoLog") command	157
5.2.29.110. CaoRobot::Execute("ClearServoLog") command	157
5.2.29.111. CaoRobot::Execute("StopServoLog") command.....	157
5.2.29.112. CaoRobot::Execute("GetCtrlLogMaxTime") command.....	157
5.2.29.113. CaoRobot::Execute("SetCtrlLogMaxTime") command	158
5.2.29.114. CaoRobot::Execute("GetCtrlLogInterval") command.....	158
5.2.29.115. CaoRobot::Execute("SetCtrlLogInterval ") command	158
5.2.29.116. CaoRobot::Execute("DetectOn ") command.....	159
5.2.29.117. CaoRobot::Execute("DetectOff ") command.....	159
5.2.29.118. CaoRobot::Execute("GetPluralServoData ") command.....	160
5.2.29.119. CaoRobot::Execute("AngularTrigger ") command	160
5.2.29.120. CaoRobot::Execute("VirtualFence") command.....	161
5.2.29.121. CaoRobot::Execute("ExclusiveArea") command	161
5.2.29.122. CaoRobot::Execute("SetExclusiveArea") command	162
5.2.29.123. CaoRobot::Execute("ResetExclusiveArea") command	162
5.2.29.124. CaoRobot::Execute("ExclusiveControlStatus") command.....	162
5.2.29.125. CaoRobot::Execute("GetAllSrvData") command	163
5.2.29.126. CaoRobot::Execute("CurForceParam") command	164
5.2.29.127. CaoRobot::Execute("GetLogCount") command	165
5.2.29.128. CaoRobot::Execute("GetLogRecord") command	165
5.2.29.129. CaoRobot::Execute("GetForceLogRecord") command	166
5.2.30. CaoRobot::Execute method (dedicated for COBOTTA)	166
5.2.30.1. CaoRobot::Execute("AutoCal") command	167
5.2.30.2. CaoRobot::Execute("MotionPreparation") command	168
5.2.30.3. CaoRobot::Execute("GetMotionPreparationState") command	168
5.2.30.4. CaoRobot::Execute("GetMechaButtonState ") command	169
5.2.30.5. CaoRobot::Execute("ClearMechaButtonState") command.....	170
5.2.31. CaoTask::AddVariable method	170
5.2.32. CaoTask::get_VariableNames property	170
5.2.33. CaoTask::Start method.....	170
5.2.34. CaoTask::Stop method.....	170
5.2.35. CaoTask::Execute method.....	171
5.2.35.1. CaoTask::Execute("GetStatus") command	172
5.2.35.2. CaoTask::Execute("GetThreadPriority") command.....	172
5.2.35.3. CaoTask::Execute("SetThreadPriority") command	172
5.2.36. CaoVariable::get_Value property	173
5.2.37. CaoVariable::put_Value property	173

5.2.38. CaoExtension::Execute method	173
5.2.38.1. Hand object - CaoExtension::Execute("Chuck") command.....	175
5.2.38.2. Hand object - CaoExtension::Execute("UnChuck") command	176
5.2.38.3. Hand object - CaoExtension::Execute("Motor") command.....	176
5.2.38.4. Hand object - CaoExtension::Execute("Org") command	176
5.2.38.5. Hand object - CaoExtension::Execute("MoveP") command.....	177
5.2.38.6. Hand object - CaoExtension::Execute("MoveA") command.....	177
5.2.38.7. Hand object - CaoExtension::Execute("MoveR") command.....	178
5.2.38.8. Hand object - CaoExtension::Execute("MoveAH") command	178
5.2.38.9. Hand object - CaoExtension::Execute("MoveRH") command.....	178
5.2.38.10. Hand object - CaoExtension::Execute("MoveH") command	179
5.2.38.11. Hand object - CaoExtension::Execute("MoveZH") command.....	179
5.2.38.12. Hand object - CaoExtension::Execute("Stop") command.....	180
5.2.38.13. Hand object - CaoExtension::Execute("CurPos") command.....	180
5.2.38.14. Hand object - CaoExtension::Execute("GetPoint") command.....	181
5.2.38.15. Hand object - CaoExtension::Execute("get_EmgState") command	181
5.2.38.16. Hand object - CaoExtension::Execute("get_ZonState") command	182
5.2.38.17. Hand object - CaoExtension::Execute("get_OrgState") command.....	182
5.2.38.18. Hand object - CaoExtension::Execute("get_HoldState") command	182
5.2.38.19. Hand object - CaoExtension::Execute("get_InposState") command.....	183
5.2.38.20. Hand object - CaoExtension::Execute("get_Error") command.....	183
5.2.38.21. Hand object - CaoExtension::Execute("get_BusyState") command.....	184
5.2.38.22. Hand object - CaoExtension::Execute("get_MotorState") command	184
5.2.38.23. K3Hand object - CaoExtension::Execute("Motor") command	184
5.2.38.24. K3Hand object - CaoExtension::Execute("Speed") command	185
5.2.38.25. K3Hand object - CaoExtension::Execute("MoveJ") command.....	185
5.2.38.26. K3Hand object - CaoExtension::Execute("BusyState") command	186
5.2.38.27. K3Hand object - CaoExtension::Execute("CurPos") command	186
5.2.38.28. K3Hand object - CaoExtension::Execute("DestPos") command.....	186
5.2.38.29. K3Hand object - CaoExtension::Execute("GetParam") command.....	187
5.2.38.30. K3Hand object - CaoExtension::Execute("SetParam") command	187
5.2.38.31. K3Hand object - CaoExtension::Execute("GetPoint") command	188
5.2.38.32. K3Hand object - CaoExtension::Execute("SetPoint") command.....	188
5.2.38.33. K3Hand object - CaoExtension::Execute("SavePoint") command.....	188
5.3. Variable list.....	189
5.3.1. Controller class	189
5.3.2. Robot class	194

5.3.3. Task class.....	196
5.3.4. File class	198
5.4. Event list	199
Appendix A. CaoController Object Creation	201
Appendix B. POSEDATA Type Definition.....	203
Appendix C. Simultaneous Command Issuance to RC8 controller	209
Appendix D. Non-Stop Motion Calculator - Trajectory Generator Command for Non Stop Inspection	211

1. Introduction

This document describes external specifications of the Cao provider for RC8 controller of the Denso robot (including VRC1) compliant to ORiN Ver. 2 specifications. In this document, Cao provider for RC8 is called RC8 provider.

This document describes the RC8 provider specifications on connection procedures, variables, I/O access, file manipulation, task control, robot control, end-effector control and original enhancement.

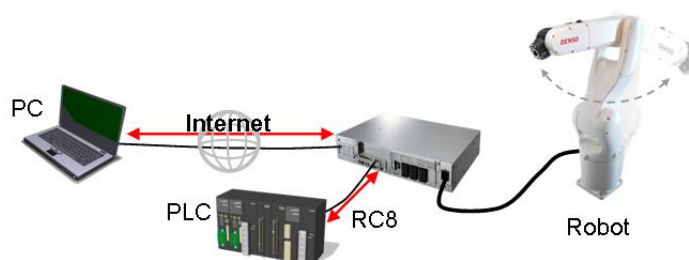

1.1. System requirements and versions assumed in this document

As the system requirements, the client PC is assumed to run on Windows and the target robot controller is assumed to be RC8 or later.

The required development environment on the PC is a programming environment that supports Component Object Model (COM).

1.2. Information sources for your reference

Although the programming examples in this document are written in Visual Basic 6.0, development is possible using various programming languages such as C++, Java, .NET, LabVIEW, and Delphi. For details about usages, refer to the "ORiN 2 Programming Guide".

"ORiN2 Programming Guide" is provided as the following file in the ORiN2 SDK installation folder.

- ORiN2\CAO\Doc\ORiN2_ProgrammersGuide_<lang>.pdf

* Read the <lang> part as characters that represent the language used in each environment.

¹ VRC (Virtual Robot Controller) is manufactured by DENSO WAVE INCORPORATED. To use the VRC, you need to prepare VRC license separately.

This guide describes the basic knowledge and technology of ORiN2, COM, and DCOM that are required to develop applications by using the provider with examples.

Also, please refer to the following documents if required.

b-CAP Provider User's Guide

- ORiN2\CAO\ProviderLib\b-CAP\Doc\b-CAP_ProvGuide_<lang>.pdf

NetwoRC Provider User's Guide (Provider for RC7 Controller)

- ORiN2\CAO\ProviderLib\DENSO\NetwoRC\Doc\NetwoRC_ProvGuide_<lang>.pdf.

2. Environment Setup for Application Development

2.1. Setup of PC development environment

2.1.1. Automatic installation of RC8 provider

With ORiN2 SDK Ver 2.1.9 or later, RC8 provider is set up by an installer.

If ORiN2 SDK Ver 2.1.9 or later is installed, the operation environment (runtime) for connecting to the RC8 robot controller (hereinafter referred to as the robot controller) is ready.

To set up a development environment, prepare a programming environment that supports Component Object Model (COM), such as Microsoft Visual Studio 6.0, 2003/2005/2008/2010 and LabVIEW.

2.1.2. Manual installation of RC8 provider

To set up RC8 provider without using the installer, registry need to be manually registered according to the table below.

Table 2-1 RC8 provider

File name	CaoProvRC8.dll
ProgID	CaoProv.DENSO.RC8
Registry registration	Regsvr32 CaoProvRC8.dll
Remove registry registration	Regsvr32 /u CaoProvRC8.dll

To use the Cao Engine module, you need to register a legitimate license key for each PC. Refer to "License registration" section of "ORiN2 SDK User's Guide".

2.2. Setup of RC8 controller

2.2.1. Emergency stop device position

A robot emergency stop switch should be prepared and set up near a robot operator before operating the robot, so that the switch can immediately stop the robot motion in an emergency situation.

- (1) The emergency stop switch should be red-colored.
- (2) After the emergency stop switch is activated, the switch should not return to normal (robot operating) position automatically or by other operator's careless action.
- (3) A robot emergency stop switch should be set up separately from the power switch.

2.2.2. Preparation of hardware

The following shows the basic hardware configurations that can be used for the robot controller clients.

When designing equipment, consider the system configuration for the software required by the customer and prepare hardware accordingly.

(1) PC-based robot system

- Configuration with one RC8 unit

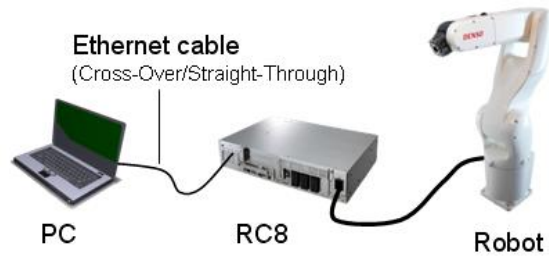

- Configuration with more than one RC8 unit

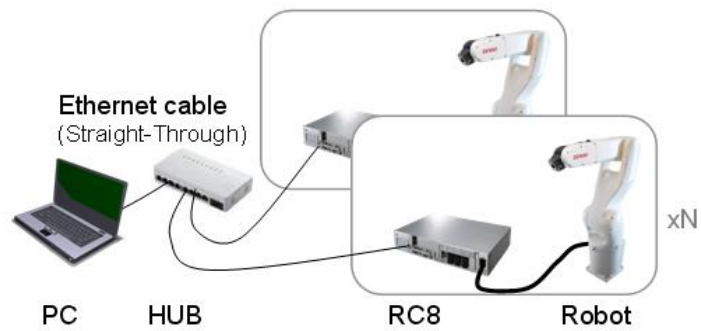

(2) RC8-based robot system

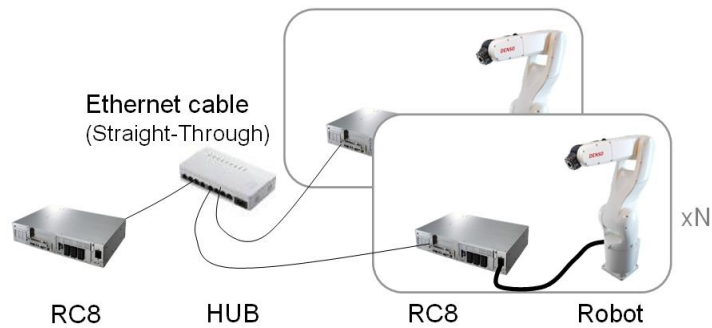

Table 2-2 Configurations of robot systems

Hardware		Software			
Client	Connection type	OS	Programming language	Dependent module	Remarks
(1) PC-based	Ethernet (TCP/IP)	Windows	C,C++,C#,VB,VB A, Java,LabVIEW Delphi, Python, Ruby,... (Environment that supports DCOM technology)	ORiN2 SDK (Cao, RC8/ b-CAP/VRC providers)	- Using ORiN2 technology, all APIs supported by RC8 are available for use. - ORiN2 SDK is required for the client PC.
		Linux (others)	C, C++ (Environment that supports socket communications)	Socket library	- All APIs supported by RC8 are available for use because b-CAP protocol is supported using the socket communications technology.
(2) RC8- based	Ethernet, I/O	RC8-dependent Windows	PacScript (VBA-based)	Standard equipment of ORiN2 SDK (Cao and RC8/b-CAP/VRC providers)	- With the standard equipment functions, all APIs supported by RC8 are available for use.

2.2.3. Setup of system parameters

Before using the RC8 provider, the robot controller to be controlled must be set up.

Either a teach pendant (TP) or mini pendant (MiniTP) is required to set up the system parameters. The systems parameters that need to be set up are (1) communication permission and (2) activation authority.

A communication permission is a control authority to write or read data to or from the robot controller. Communication device cannot write or read data to or from the robot controller unless it obtain this permission. You need to assign a writing permission to the device to use when you write variable data or control a robot.

An activation authority is a control authority that is necessary for starting the robot controller’s program tasks (program execution), turning ON motors, and controlling robot (motion command). Communication device cannot perform these operation unless it obtains this authority. Either (1) TP, (2) I/O, (3) Ethernet, or (4) Any can be set. Setting "Any" gives activation authority regardless of the communication routing. When setting "Any," execute exclusive processing between communication devices to prevent collisions between the client PCs and PLCs.

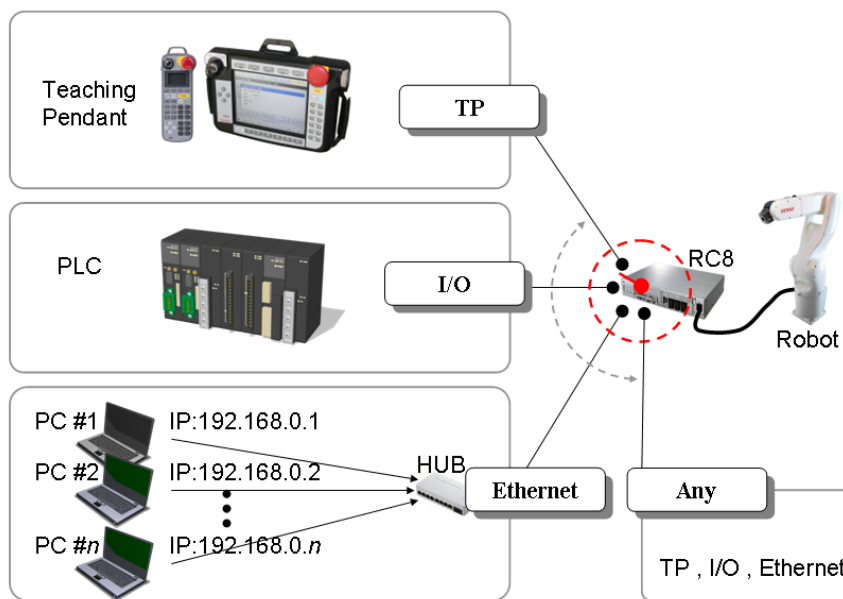

Figure 2-1 Setup of devices with activation authority

When using Ethernet as the connection method, the IP addresses of client PCs must be set. When this setting is selected, the robot controller allows only specific client PCs to activate a program task or control the robot.

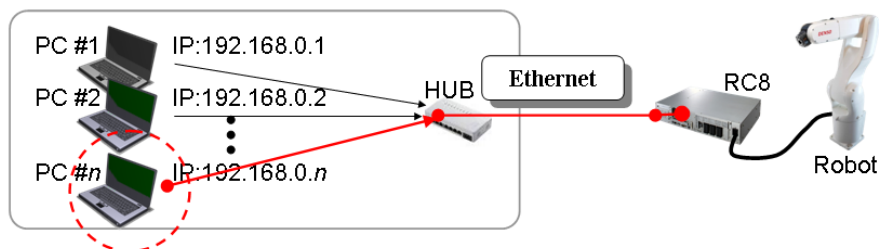

Figure 2-2 Setup of clients with activation authority

The following sections describe the setup methods using each of these settings.

2.2.3.1. Setup using a teach pendant

Set the IP address of a robot controller using a teach pendant according to the following procedure.

- (1) **Set** the robot controller **to the Manual mode**.



(2) **Set the activation authority** of the robot controller.

To use Ethernet, select the teach pendant's [F6 Setup] menu -> [F5 Communication and Token] -> [F1 Executable Token] and set the activation authority to Ethernet.

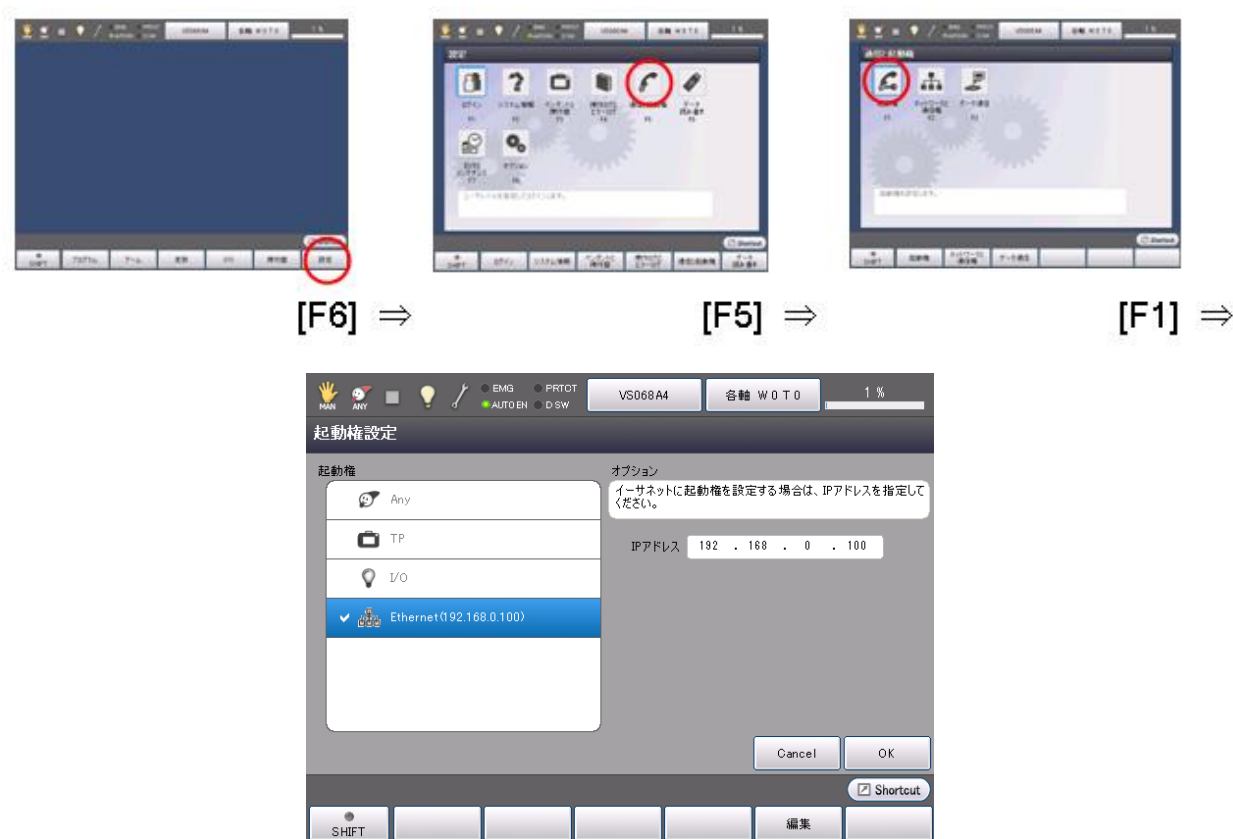

Figure 2-3 Setting of activation authority

Press [F5 Edit]. Set the IP address of the client that assigns activation authority to the robot controller.

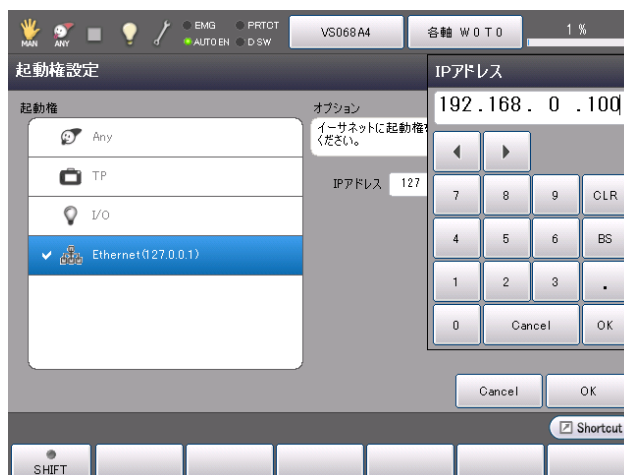

Figure 2-4 Setting of IP addresses of clients

- (3) Set the network and communication permissions of the robot controller.

To use Ethernet, select the teach pendant's [F6 Setup] menu -> [F5 Communication and Token] -> [F2 Network and Permission] and set the read/write permissions to Ethernet.



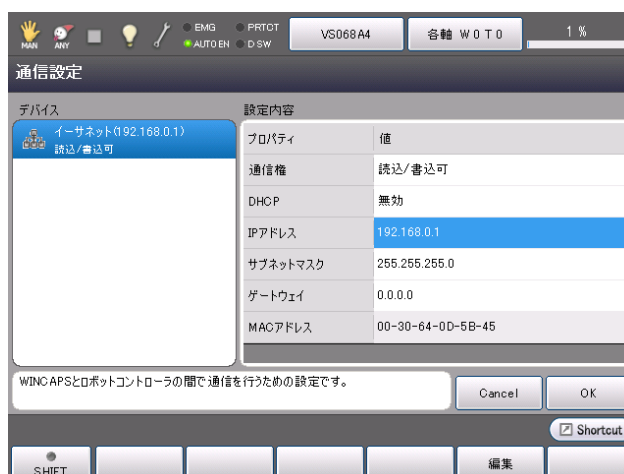

Figure 2-5 Communication settings

Press [F5 Edit]. Set IP addresses and subnet masks of the robot controllers. Set the gateway address if required.

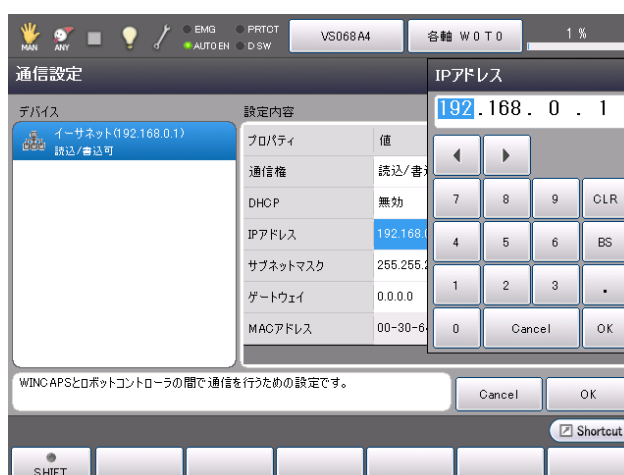

Figure 2-6 Setting of IP addresses of robot controllers

2.2.3.2. Setup using a mini pendant

Set the IP address of a robot controller using a mini pendant according to the following procedure.

- (1) **Set** the robot controller **to the Manual mode**.



- (2) **Set the activation authority** of the robot controller.

Press [COM] to display the [COM Setting] window shown below which lists communications settings for the robot controller.

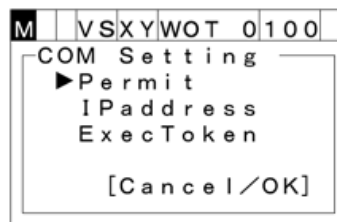

Figure 2-7 List of communications settings

Select "Exec Token" with the up and down cursor keys, and then press [OK] to display the [Exec Token] window shown below which lists activation authority settings.

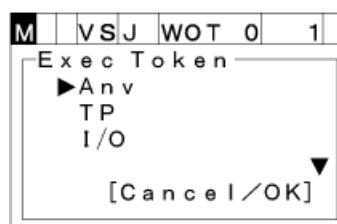

Figure 2-8 List of activation authority settings

Select "Ether" with the up and down cursor keys, and then press [OK]. The [Client IP] window is displayed as shown below. Set the IP address of the client that assigns activation authority to the robot controller.

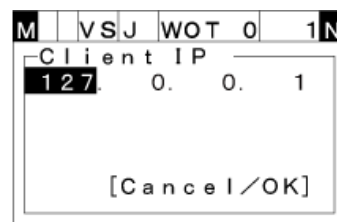

Figure 2-9 Setting of IP addresses of clients

Press [OK] to confirm the change.

Press [Cancel] to cancel the change.

- (3) **Set the communication permission** of the robot controller.

Press [COM] to display the [COM Setting] window shown below which lists communications settings for the robot controller.

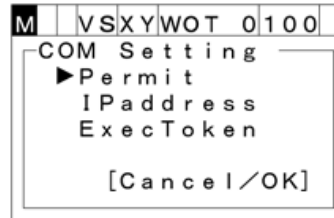

Figure 2-10 List of communications settings

Select "Permit" with the up and down cursor keys, and then press [OK] to display the [Permission] window which lists port options as shown below.

(Off): Not available, (R): Read only, (RW): Read/write available

Press [Cancel] to exit the communications setting.

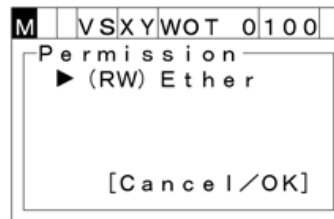

Figure 2-11 List of port options

Select "Ether" and press [OK]. The [Permit-Ether] window is displayed as shown below which lists communication options.

Press [Cancel] to exit the communications setting.

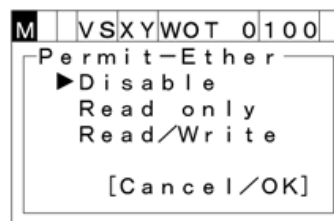

Figure 2-12 List of communication options

Using the up and down cursor keys, select one from "Disable," "Read only," and "Read/write". Press [OK] to change the communication permission.

Press [Cancel] to cancel the change of the communication permission.

- (4) **Set the network** of the robot controller.

Press [COM] to display the [COM Setting] window shown below which lists communications settings.

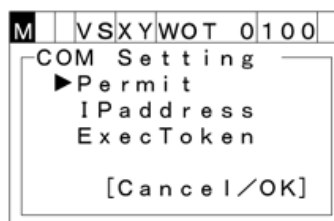

Figure 2-13 List of communications settings

Using the up and down cursor keys, select "IP address" and press [OK] to display the [IP address] setting window as shown below.

Press [Cancel] to exit the communications setting.

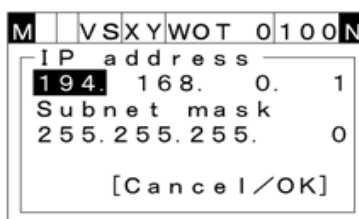

Figure 2-14 IP address setting screen

Select an item using the up/down/left/right cursor keys. The value can be changed by using the numeric entry keys.

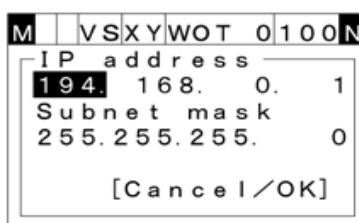

Figure 2-15 Change of IP addresses

Press [OK] to confirm the change.

Press [Cancel] to cancel the change.

2.3. Operation check using CaoTester

Before running a developed client application, check that the RC8 robot controller to be controlled has been set up correctly using CaoTester, an ORiN2 SDK standard tool.

2.3.1. Check of variable access

Perform the variable access operation using CaoTester and check that the client PC has a basic connection with the target robot controller according to the procedure shown below. If this operation cannot be correctly performed, the client PC installation environment or the network environment and settings of the target robot controller may fail and you will have to perform the setup again.

- (1) Activate CaoTester.

To activate CaoTester, select [ORiN2\CAO\Tools\CaoTester\Bin\CaoTester.exe] in the ORiN2 SDK installation folder.

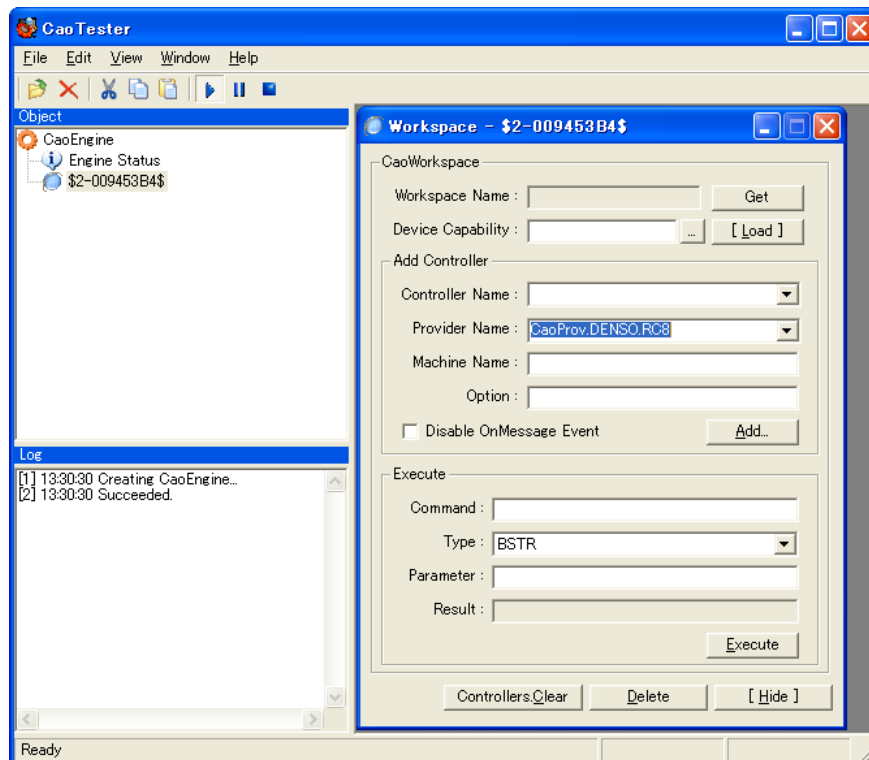

Figure 2-16 Initial window of CaoTester

(2) Select the [Workspace] window and set parameters in [Add Controller].

For the purpose of explanation, the target controller is assumed to have an IP address of 192.168.0.1.

Read the settings as those in your actual environment.

Controller Name : RC8
Provider Name : CaoProv.DENSO.RC8
Machine Name : <Blank>
Option : Server=192.168.0.1 * IP address of the target controller

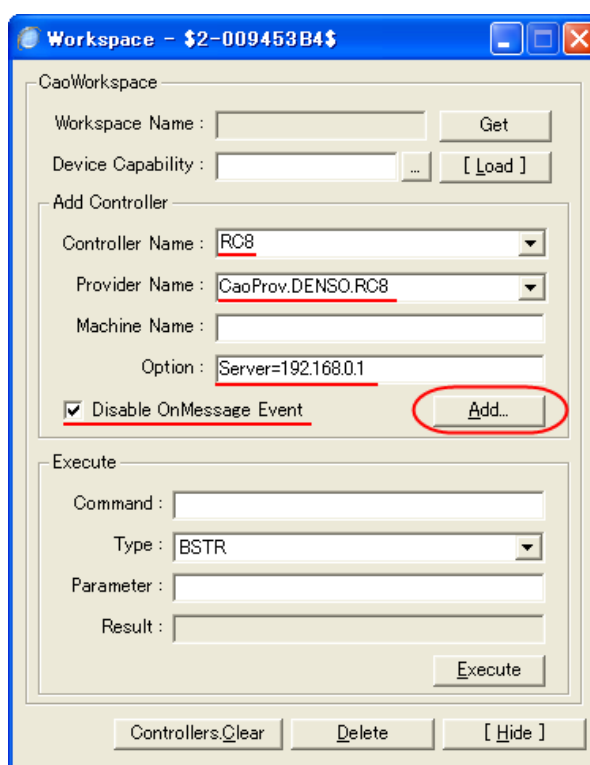

Figure 2-17 [Workspace] window

- (3) Press the [Add] button in the [Workspace] window to display the [CaoController] window.

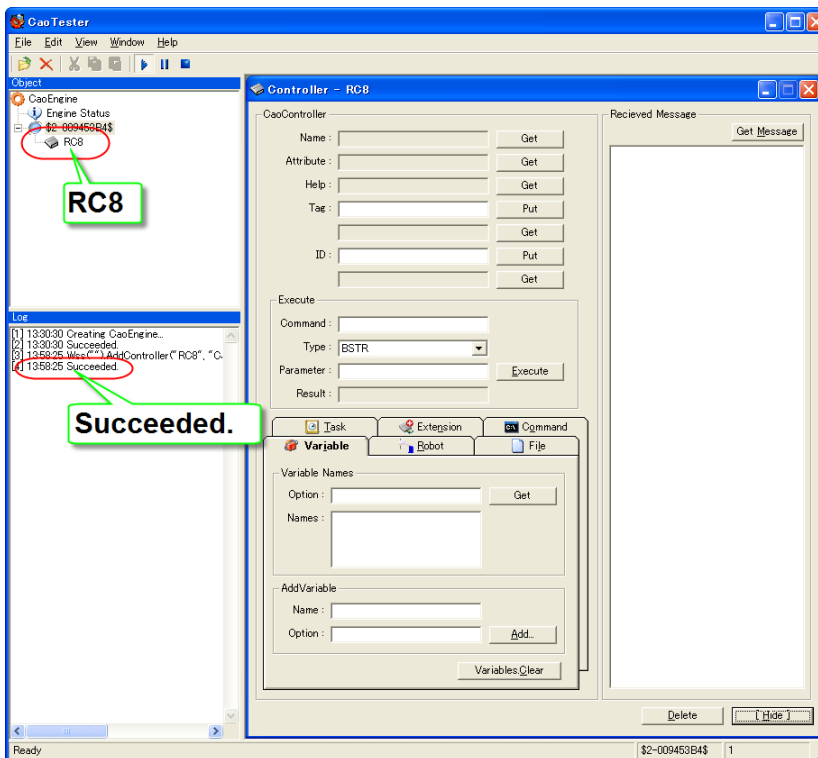

Figure 2-18 [CaoTester] window while creating [Controller] window

- (4) In the [Controller] window, select a [Variable] tab and create a [Variable] window for I1 variable in [AddVariable].

Name : I1
 Option : <Blank>

In [AddVariable], set the parameters shown above and press the [Add..] button.

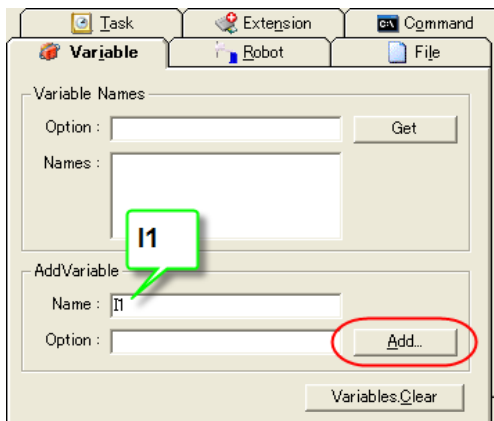

Figure 2-19 [Variable] tab settings

- (5) Access the variable. On the [Variable] window, select [Value] textbox.
Press the [Get] and [Put] buttons to access the value of the target controller.

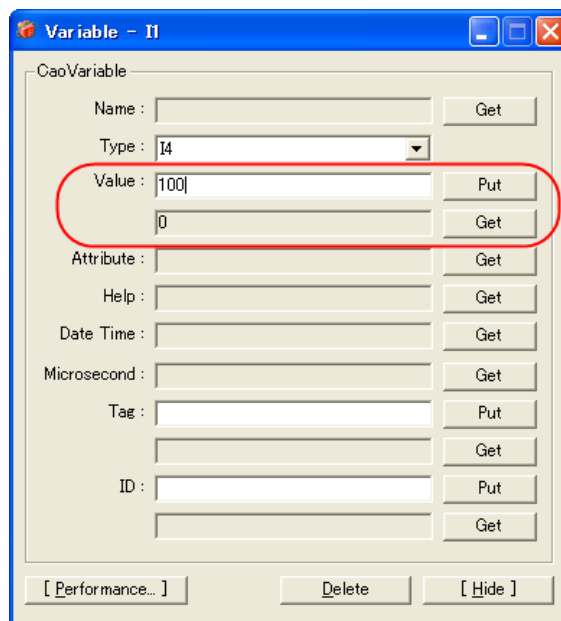

Figure 2-20 [Value] setting in [Variable] window

2.3.2. Check that the motor is ON

Turn ON and OFF the motor power using CaoTester to check that the client PC can control the motor power with the target robot controller, according to the procedure shown below. If this operation cannot be correctly performed, the activation authority over the target robot controller may not be correctly set on the client PC. In that case, check the activation authority setting again.

- (1) **Set** the robot controller **to the Auto mode**.



(2) Select the [Controller] window of CaoTester. Select a [Robot] tab, and create a [Robot] window.

Name : Arm0
 Option : <Blank>

In [AddRobot], set the parameters shown above and press the [Add..] button.

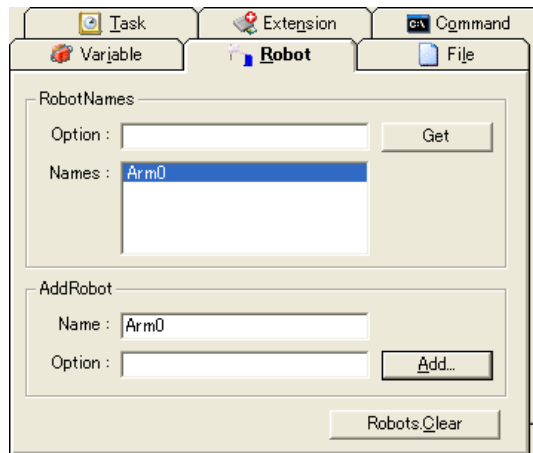

Figure 2-21 [Robot] tab settings

(3) In the [Robot] window, access the [Variable] tab and create a [Variable] window for @SERVO_ON in [AddVariable].

Name : @SERVO_ON
 Option : <Blank>

In [AddVariable], set the parameters shown above and press the [Add..] button.

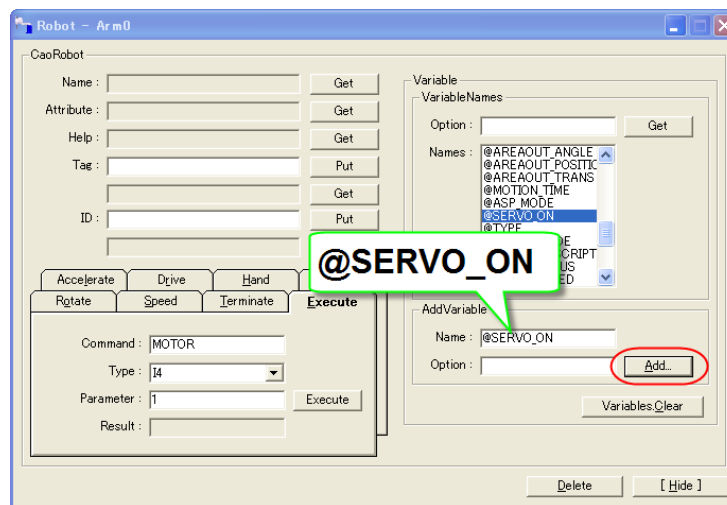

Figure 2-22 [Robot] window settings

- (4) Turn ON or OFF the motor power in [Value] in the [Variable] window.

Press the [Get] and [Put] buttons to turn ON (1) and OFF (0) the motor power of the target controller.

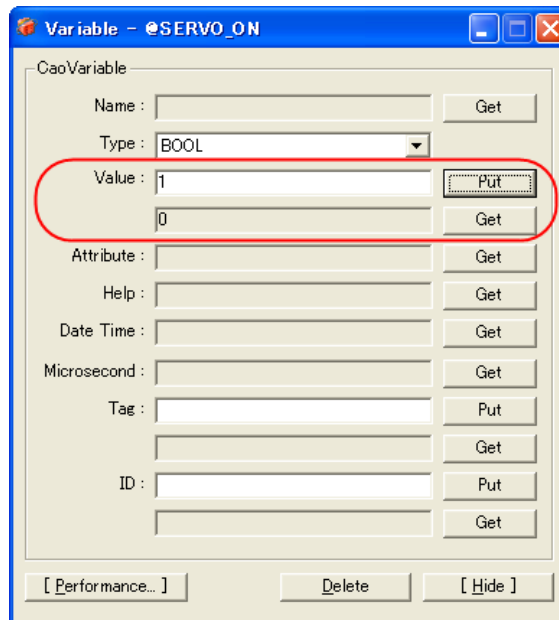

Figure 2-23 [Value] setting in [Variable] window

3. Basic Knowledge on RC8 Programming

3.1. Outline of RC8 provider

3.1.1. Functions provided by RC8 provider

The RC8 provider provides a wide range of ORiN2 compliant-APIs so that it can invoke all functions that are provided to external devices from the robot controller. The following table shows the outline of functions provided by the RC8 provider. For the details, refer to "5. Command Reference".

Table 3-1 Outline of RC8 provider functions

Function name	Category	Remarks
Event notification	CaoController	Can receive error notifications and status changes of the controller as OnMessage event asynchronously.
Variables access	CaoVariable	Can read/write I/O, global variables, and system parameters. Can also acquire information and statuses of a wide range of controller resources.
File manipulation	CaoFile	Can acquire information on and manipulate files and folders.
Task control	CaoTask	Can control the status acquisition, activation, and stop of tasks to be executed. Also can perform task-to-task communications using message queues of tasks.
Robot control	CaoRobot	Can control robots using turn ON/OFF of motor power, operation speeds/operation commands of robots, and TOOL/WORK/AREA settings, etc.
Expansion Board	CaoExtension	Can set and acquire parameters of the electric gripper, acquire status, and control motion commands.

3.1.2. System configuration of RC8 provider

The RC8 provider is a core module independent of the hardware of the robot controller. The RC8 provider establishes the compatibility between the simulation and the RC8 robot controller; this will solve the inconsistency of the robot motion between programs created by the simulation and programs created by the RC8 robot controller.

The following shows the system configuration for connecting a PC and an RC8 robot controller.

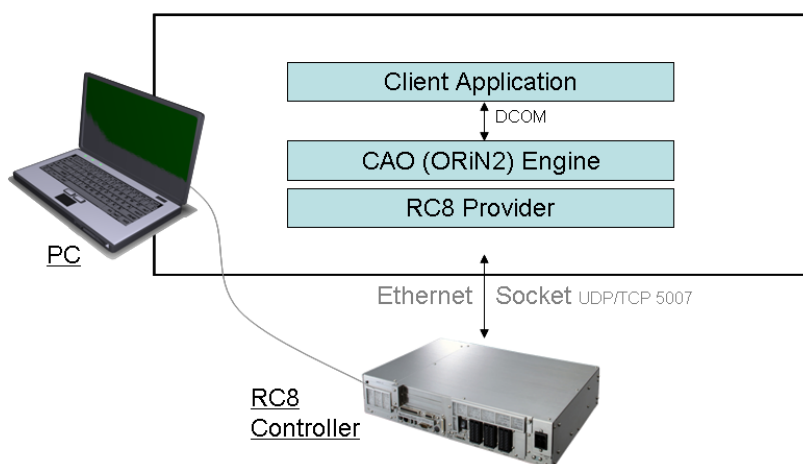

Figure 3-1 System configuration of PC and RC8

This connection route is determined according to the connection parameter that is specified when Client Application connects to the RC8 provider (AddController). If you assign IP address ("Server=...") of the robot controller to the RC8 provider, it will connect to the robot controller; if you assign a project file ("wpj=...") of WINCAPS3 to the RC8 provider, it will connect to the VRC.

3.1.2.1. Configuration of Cao engine and Cao provider

Cao providers such as the RC8 provider are plug-ins of the Cao engine of ORiN2. Therefore, understanding of class configuration of the Cao engine is required to create a client application.

The following figure shows the class configuration of the Cao engine and the Cao provider.

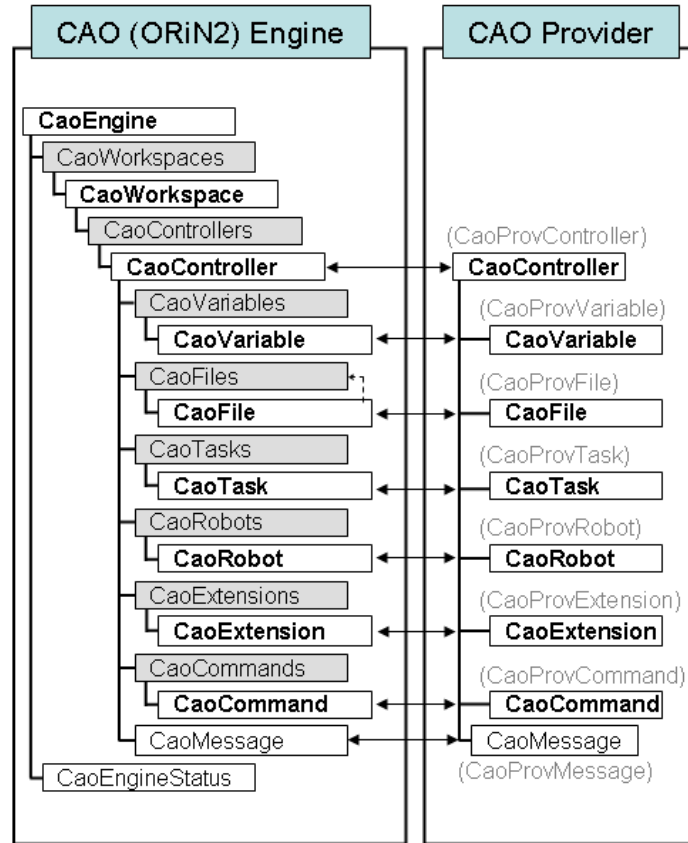

Figure 3-2 Configuration of Cao engine and provider

The class configuration of the Cao engine is a model of resources owned by general devices including robot controllers. A client application, by accessing the classes provided by the Cao engine, can indirectly access the devices to be connected.

3.1.3. HRESULT and handling of errors

If a value of HRESULT that represents a response of the methods and properties of classes of the Cao provider is 0 or higher, it means that the processing has been successfully completed. On the other hand, a negative value represents that the call failed.

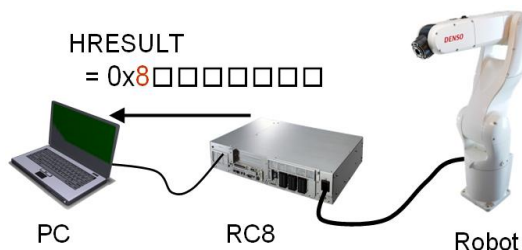

Figure 3-3 Error in call from PC

If the error of HRESULT is 0x8□□□□□□□□, look up the error in the table of error codes in the manual provided with the robot controller.

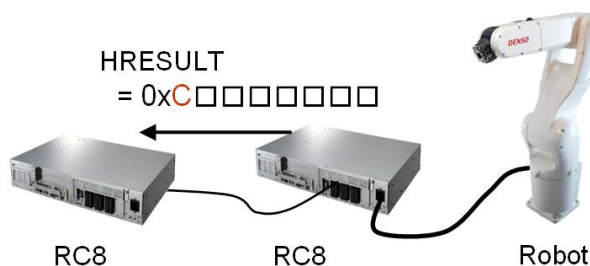

Figure 3-4 Error in call from RC8

If the error of HRESULT is 0xC□□□□□□□□, read 0xC as 0x8 and look up the error in the table of error codes in the manual provided with the robot controller.

3.1.4. Handling of property definitions

To explain the property specifications of each class of the Cao provider, the following formats are used throughout this manual.

Property acquisition <Variable to be substituted> = Obj.PropertyName

Handled as <Variable to be substituted> = Obj.get_Property()

get_PropertyName Acquisition of the value of <PropertyName> property

Property setting Obj.PropertyName = <Setting value>

Handled as Obj.put_Property (<Setting value>).

put_PropertyName Setting of the value of <PropertyName> property

3.1.5. Execution method and runtime binding

If a method not defined in the target class is called by using the runtime binding function, the Execute method is automatically called according to the following specifications:

```
vntRet = Obj.CommandName( Param1, Param2, ... )
```

↓

```
vntRet = Obj.Execute("CommandName", Array(Param1, Param2, ... ) )
```

1. The command name is passed as a BSTR string to the first argument.
2. All the parameters are passed as a VARIANT array to the second argument.

To realize these specifications, the Execute method of each class of the Cao provider is defined as follows:

Syntax [`<vntRet:VARIANT> =] Execute(<bstrCmd:BSTR > [,<vntParam:VARIANT>])`

bstrCmd	:	[in]	Command name, BSTR type string
vntParam	:	[in]	Parameter, VARIANT type array (or singular)
vntRet		[out]	Return value, VARIANT type

The arguments of the Execute method specify a command as a BSTR and a parameter as a VARIANT array.

4. RC8 Programming Using the Provider

To control robots with RC8 provider, communication between an ORiN installed PC and the robot controller should be established with Ethernet. Some commands also require the robot controller setup. For details of setup, refer to "2 Environment Setup for Application Development" and for details of commands, refer to "5 Command Reference".



Figure 4-1 Robot connection

The developed program uses RC8 provider to communicate with the robot controller, by generating a socket (UDP/TCP).

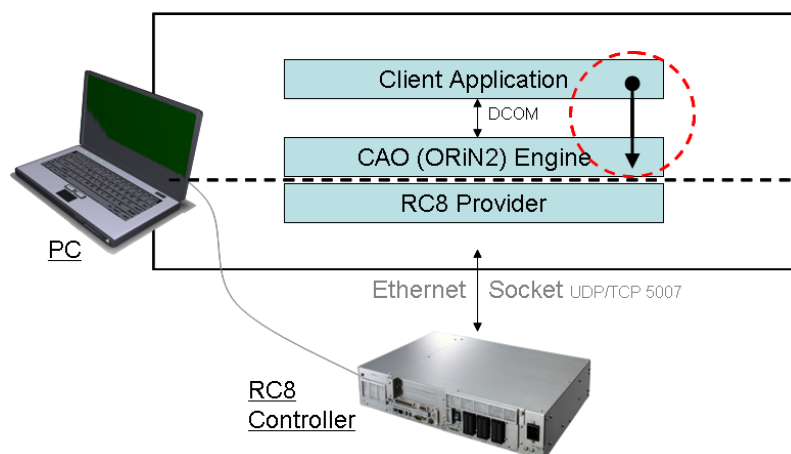

Figure 4-2 Outline of programming

RC8 provider establishes communication between the PC and the robot controller by the following procedure:

- Create CaoEngine
- Create CaoWorkspace
- Create CaoController

After the communication is established, variables in the controller will be accessed by creating a CaoVariable object, and robot motions will be initiated by creating a CaoRobot object. Examples in the following section explain the procedure of robot programming.

4.1. RC8 controller variable access

Figure 4-3 shows the procedure to access variables.

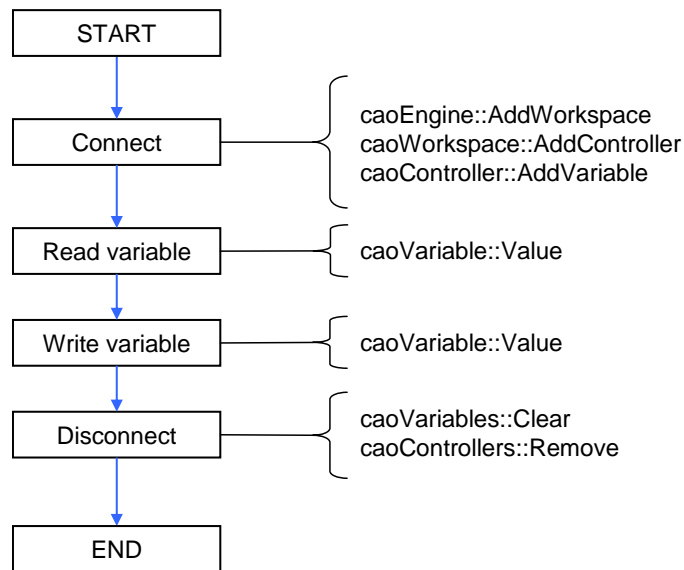

Figure 4-3 Variable access

4.1.1. Connection

Following is the procedure to establish connection to the robot controller.

- (1) Create variables to store objects. CaoEngine object, CaoWorkspace object, and CaoController object are required to establish communication to the robot controller. CaoWorkspace object does not need to prepare a variable if CaoController object is acquired from CaoWorkspaces. CaoVariable object is also necessary to access variables. Following is an example code in VB6.

```

-----
Dim g_eng as CaoEngine           ' CaoEngine object variable
Dim g_wrks as caoWorkspace      ' CaoWorkspace object variable
Dim g_ctrl as CaoController     ' CaoController object variable
Dim g_val as CaoVariable        ' CaoVariable object variable
-----
  
```

- (2) Create a CaoEngine object. CaoEngine object is created with New keyword.

```

-----
Set g_eng = New CaoEngine       ' CaoEngine object creation
-----
  
```

- (3) Acquire or create a CaoWorkspace object. When created, CaoEngine object automatically creates one Caoworkspaces object and one Caoworkspace object. The next sample program uses the automatically created workspace. Following is an example code for creating a new CaoWorkspace object.

```
Set g_wrks = g_eng.Addworkspace("NewWrks", "")
```

- (4) Create a CaoController object. To create a CaoController object, specify the provider name and its parameters. RC8 provider specifies the destination controller IP address as an option. Following is an example code.

```
Set g_ctrl = g_wrks.AddController("RC8", "CaoProv.DENSO.RC8", "", "Server=192.168.0.1")
```

- (5) Create a CaoVariable object for a variable that you intend to connect. Following is an example code for accessing the 10th element of P-type variable.

```
Set g_val = g_ctrl.AddVariable("P10", "")
```

4.1.2. Variable read/write access

To read and write the connected variable value, use Value property of CaoVariable object. To read and write value, another variable with the suitable type for the connected variable should be prepared. Following is an example code.

```
Dim vntPotision as Variant  
vntPotision = g_val.Value  
g_val.Value = Array(50, 50, 50, 0, 0, 0, -1)
```

4.1.3. Disconnection

To disconnect from the controller, delete not only the created object itself, but also delete the object from a collection class that manages the object. Following is an example code.

```
-----  
g_ctrl.Variables.Clear                ' Delete all objects from CaoVariables  
Set g_val = Nothing                   ' Delete CaoVariable  
g_wrks.Controllers.Remove g_ctrl.Index ' Delete CaoController from CaoControllers  
Set g_ctrl = Nothing                  ' Delete CaoCtonroller  
g_eng.Workspaces.Remove g_wrks.Index  ' Delete CaoWorkspace from CaoWorkspaces  
Set g_wrks = Nothing                  ' Delete CaoWorkspace  
Set g_eng = Nothing                   ' Delete CaoEngine  
-----
```

4.1.4. Sample program

Following is an example program written in VB6. The sample program uses the automatically created workspace and reads/writes the variable IO150 (the 150th I/O variable). IP should be set to the value for the target controller. This sample program uses following value.

IP:192.168.0.1

List 4-1 Variable.frm

```
Dim g_eng As CaoEngine
Dim g_ctrl As CaoController
Dim g_val As CaoVariable

Private Sub Command1_Click()
    ' Read variable
    Text1.Text = g_val.Value
End Sub

Private Sub Command2_Click()
    ' Write variable
    g_val.Value = CBool(Text2.Text)
End Sub

Private Sub Form_Load()
    Set g_eng = New CaoEngine

    ' Connect RC: IP setting depends on your RC setting.
    Set g_ctrl = g_eng.Workspaces(0).AddController("RC8", "CaoProv.DENSO.RC8", "",
"Server=192.168.0.1")

    ' Variable name "IO150"
    Set g_val = g_ctrl.AddVariable("IO150", "")

End Sub

Private Sub Form_Unload(Cancel As Integer)
    ' Delete variable object
    g_ctrl.Variables.Clear
    Set g_val = Nothing

    ' Delete controller object
    g_eng.Workspaces(0).Controllers.Remove g_ctrl.Index
    Set g_ctrl = Nothing

    ' Delete CaoEngine
    Set g_eng = Nothing
End Sub
```

4.2. Task control with RC8 controller

To perform task control, perform the processing described in Figure 4-4. To run a task, the controller must be in AUTO mode. Furthermore, the activation authority of the controller must be set to the IP of an ORiN installed PC. For more details, refer to "2.2.3 Setup of system parameters".

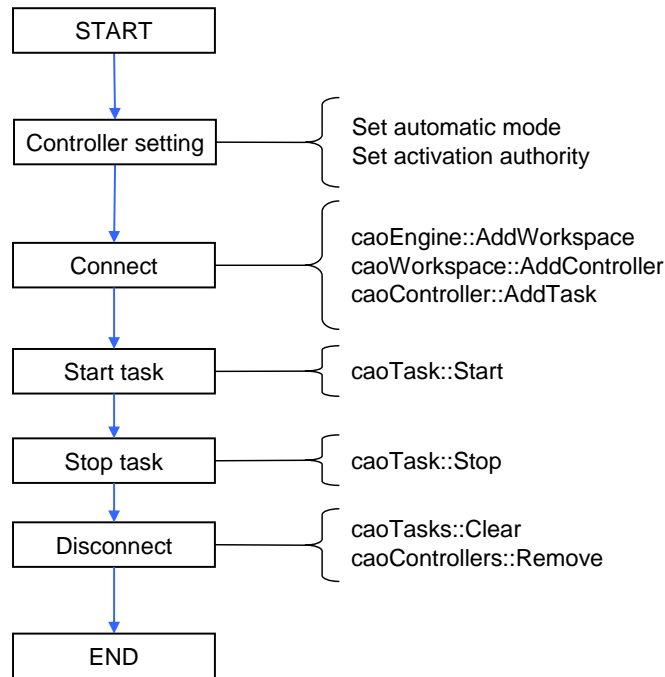

Figure 4-4 Task control flow

4.2.1. Connection

For details about the procedure for creating a CaoController object, refer to "4.1.1 Connection". To control a task, create a CaoTask object. Following is an example code for creating a task object.

```

-----
Dim g_task as CaoTask      ' Variable that stores a CaoTask object
Set g_task = g_ctrl.AddTask("PRO01", "")
-----
  
```

4.2.2. Start/stop of a task

To start or stop a task, use Start method and Stop method of CaoTask objects. Following is an example of continuous execution and cycle stop of a task.

```

-----
g_task.Start 2           ' Continuous execution
g_task.Stop 3           ' Cycle stop
-----
  
```

4.2.3. Sample program

The sample program uses the automatically created workspace and controls the task "PRO01" (continuous execution and cycle stop).

List 4-2 Task.frm

```
Dim g_eng As CaoEngine
Dim g_ctrl As CaoController
Dim g_task As CaoTask

Private Sub Command1_Click()
    ' Start task
    g_task.Start 2
End Sub

Private Sub Command2_Click()
    ' Stop task
    g_task.Stop 3
End Sub

Private Sub Form_Load()
    Set g_eng = New CaoEngine

    ' Connect RC: IP setting depends on your RC setting.
    Set g_ctrl = g_eng.Workspaces(0).AddController("RC8", "caoProv.DENSO.RC8", "",
"Server=192.168.0.1")

    ' Task name "PR01"
    Set g_task = g_ctrl.AddTask("PRO1", "")
End Sub

Private Sub Form_Unload(Cancel As Integer)
    g_ctrl.Tasks.Clear
    Set g_task = Nothing

    g_eng.Workspaces(0).Controllers.Remove g_ctrl.Index
    Set g_ctrl = Nothing

    Set g_eng = Nothing
End Sub
```

4.3. Robot control with RC8 controller

To control a robot, the controller must be set to AUTO mode.

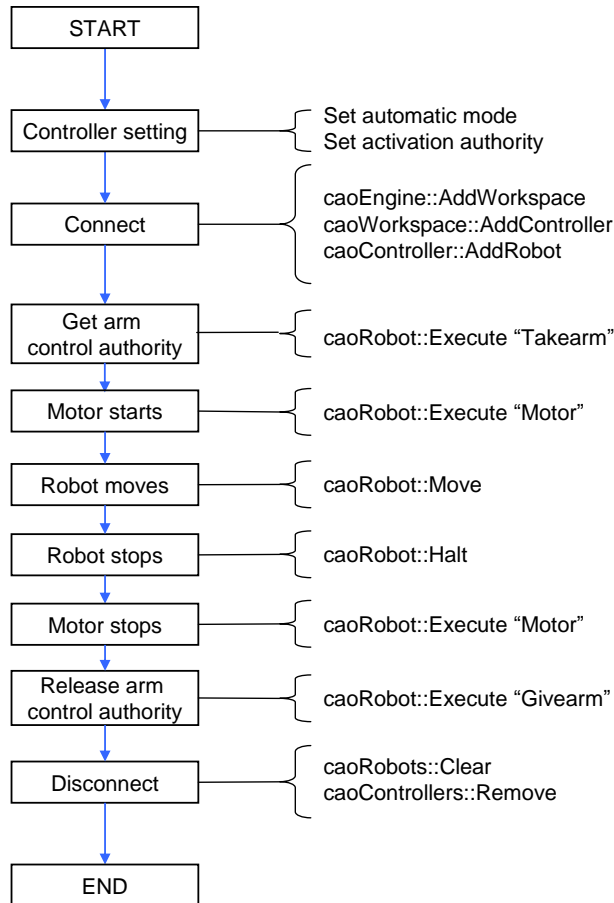

Figure 4-5 Robot control flow

4.3.1. Connection

For details about the procedure for creating a CaoController object, refer to "4.1.1 Connection". To run the robot, create a CaoRobot object. Following is an example code.

```

-----
Dim g_robot as CaoRobot                                     ' Variable that stores a CaoRobot object
Set g_robot = g_ctrl.AddRobot("Arm", "")
-----
  
```

4.3.2. Getting and release of arm control authority

To control robots, a device must obtain the arm control authority of the robot. Also, it must release the arm control authority before disconnecting from the controller. Following is an example code.

```
-----
g_robot.Execute "Takearm"           ' Get arm control authority
':
g_robot.Execute "Givearm"          ' Release arm control authority
-----
```

4.3.3. Start and stop of the motor

To control a robot, the robot motor must be running. Following is an example code for starting and stopping the motor using the RC8 provider. For further details, refer to "5.2.27.25 CaoRobot::Execute("Motor") command".

```
-----
g_robot.Execute "Motor", Array(1, 0) ' Start motor
':
g_robot.Execute "Motor", Array(0, 0) ' Stop motor
-----
```

4.3.4. Move and stop of the robot

CaoRobot::Move method moves the robot. Refer to "5.2.24 CaoRobot::Move method" for details of Move. By adding NEXT option to Move, CaoRobot::Halt method can stop the robot motion while it is moving.

```
-----
g_robot.Move 1,"P(400, 300, 200, 180, 0, 180, 5)","Next" ' Move robot
':
g_robot.Halt                                           ' Stop robot
-----
```

4.3.5. Sample program

The sample program uses the automatically created workspace and moves the robot to a position stored in P10 (10th element of P-type variable) and then moves it to the position stored in P11 (11th element of P-type variable). By adding NEXT option to Move, CaoRobot::Halt method can stop the robot motion while it is moving.

List 4-3

Robot.frm

```
Dim g_eng As CaoEngine
Dim g_ctrl As CaoController
Dim g_robot As CaoRobot
Dim g_robotVar As CaoVariable
Dim g_haltFlag As Boolean

Private Sub Command1_Click()
' Start motor if arm is stationary
If g_robotVar.Value = False Then
g_robot.Execute "Motor", Array(1, 0)
```

```
End If
End Sub

Private Sub Command2_Click()
' Stop motor if arm is stationary
If g_robotVar.Value = False Then
    g_robot.Execute "Motor", Array(0, 0)
End If
End Sub

Private Sub Command3_Click()
' Stop robot
g_robot.Halt

' Record robot stop
g_haltFlag = True
End Sub

Private Sub Command4_Click()
' Do not run new operation instruction if arm is running
If g_robotVar.Value = True Then
    Exit Sub
End If

g_haltFlag = False

' Run robot
g_robot.Move 1, "@P P10", "NEXT"

' Do not start next motion until previous motion is completed
Do Until g_robotVar.Value = False
    DoEvents
Loop

' Do not start next motion if robot has stopped
If g_haltFlag = True Then
    Exit Sub
End If

' Run robot
g_robot.Move 1, "@P P11", "NEXT"
End Sub

Private Sub Form_Load()
    Set g_eng = New CaoEngine

' Connect RC: IP setting depends on your RC setting.
Set g_ctrl = g_eng.Workspaces(0).AddController("RC8", "caoProv.DENSO.RC8", "",
"Server=192.168.0.1")

' Create CaoRobot object
Set g_robot = g_ctrl.AddRobot("Arm")

' Argument used to check arm running status
Set g_robotVar = g_robot.AddVariable("@BUSY_STATUS")

' Get arm control authority
g_robot.Execute "Takearm"

' Start motor
Command1_Click
End Sub

Private Sub Form_Unload(Cancel As Integer)
' Stop motor
Command2_Click
```

```
' Release arm control authority
g_robot.Execute "Givearm"

g_robot.Variables.Clear
Set g_robotVar = Nothing
g_ctrl.Robots.Clear
Set g_robot = Nothing
g_eng.Workspaces(0).Controllers.Remove g_ctrl.Index
Set g_ctrl = Nothing
Set g_eng = Nothing
End Sub
```



5. Command Reference

5.1. List of commands

Table 5-1 List of commands

Category	Method/property	Function	
CaoWorkspace			
	Addcontroller	Connect communication to the RC.	P.49
CaoController			
	AddFile	Connect to a file or folder (PAC, system file).	P.52
	AddRobot	Connect the robot.	P.53
	AddTask	Connect the task (PAC).	P.54
	AddVariable	Connect the user/system variable.	P.55
	get_Name	Get the controller name.	P.57
	get_FileNames	Get a list of file names.	P.57
	get_TaskNames	Get a list of tasks (PAC).	P.58
	get_VariableNames	Get a list of user/system variables.	P.58
	Execute	Execute a command of the controller class.	P.58
CaoFile			
	AddFile	Connect a PAC file.	P.70
	AddVariable	Connect a system variable of files.	P.84
	get_VariableNames	Get a list of system variable names.	P.85
	get_FileNames	Get a list of files.	P.85
	get_Size	Get the size of a file.	P.85
	get_Value	Get the value of a file.	P.86
	put_Value	Rewrite the value of a file.	P.86
CaoRobot			
	Accelerate	Set the internal acceleration and deceleration ratio of the robot.	P.86
	AddVariable	Connect a system variable.	P.87
	get_VariableNames	Get a list of system variable names.	P.87
	Halt	Stop the robot in asynchronous motion.	P.87

Change	Change the tool/user coordinate system of the robot.	P.88
Drive	This method is not supported directly in this provider.	P.88
Move	Robot moves.	P.89
Rotate	Rotate around the specified axis.	P.89
Speed	Set the internal movement speed of the robot.	P.94
Execute	Execute a command of the robot.	P.95

CaoTask

AddVariable	Connect a system variable of the robot.	P.166
get_VariableNames	Get a list of system variable names.	P.170
Start	Start the PAC program.	P.170
Stop	Stop the PAC program.	P.170
Execute	Execute a command of the task class.	P.170

CaoVariable

get_Value	Get a value.	P.173
put_Value	Set a value.	P.173

5.2. Methods and properties

5.2.1. CaoWorkspace::AddController method

RC8 provider establishes the connection to the target controller by referring to the parameters that have been passed at the AddController method execution.

The option strings specify the communication method, connection parameters and timeout period. Options are delimited by ",".

Syntax AddController(<bstrCtrlName:BSTR>,<bstrProvName:BSTR>,<bstrPcName:BSTR >

[,<bstrOption:BSTR>])

bstrCtrlName	: [in]	Controller name Specify a unique arbitrary string for each connection. <u>* An error (0x80000205) occurs if the same name is specified from a different application or another PC.</u> If an empty string ("") is specified, the Cao engine automatically assigns a unique controller name.
bstrProvName	: [in]	Provider name (Fixed to "CaoProv.DENSO.RC8")
bstrPcName	: [in]	Provider execution machine name Specify an empty string ("") for the same machine.
bstrOption	: [in]	Option character string = "<Option 1>, <Option 2>,..."

Following is a list of option string items.

Table 5-2 Option character string of CaoWorkspace::AddController

Option	Explanation
Server=<IP address>	Specify the IP address of the RC8 controller to be connected. Example: "Server=192.168.0.1"
Timeout=<Time>	Specify the communication timeout period in ms. It is 3000 ms by default. This option is enabled only when the Server option is specified.
Interval=<Time>	Specify an interval for getting a message from the connected controller in ms. It is 100 ms by default. This option is enabled only when the Server option is specified.
InvokeTimeout=<Time>	Specify the command invoke timeout period in ms. A timeout error occurs if the command processing takes longer than the specified time. It is 180000 ms by default. This option is enabled only when the Server option is specified.
WPJ={<Project file>}	To perform simulation, specify a full path of a "*.wpj" file of WINCAPS3 for a project file. To connect to the latest virtual controller that have been activated, specify "(asterisk)" for a project file. If the project file name is identical with the name of the virtual controller that has been activated, connect to that controller simultaneously. It will be "(asterisk)" if it is omitted. Example: "WPJ= {C:\ Program Files\WINCAPS3\Test\Test.wpj}" "WPJ= {"
Message=<event notice>	Notify event occurrences. (Refer to 5.4. Event List) To inform an event, set TRUE. Events will not informed when FALSE is selected. It will be TRUE if it is omitted. If the notify event is not required, it is recommended to specify False for this option.

If "@IfNotMember" is specified to an option string, an existing object corresponding to the controller name will be returned. The object of the specified name is newly made when there is no object of the same name.

Specifying an empty string ("") for the name, the @IfNotMember option will be ignored.

Example Create CaoController

```

Private caoEng As CaoEngine           ' Engine object
Private caoWs As CaoWorkspace         ' WorkSpace object
Private caoCtrl As CaoController      ' Controller object

Set caoEng = New CaoEngine
Set caoWS = caoEng.CaoWorkspaces.Item(0)
Set caoCtrl = CaoWS.AddController("rc8","CaoProv.DENSO.RC8",",",",Server=192.168.0.1,Timeout=1000")
    
```

5.2.1.1. When you establish multiple connections with RC8 controller

When the RC8 controller connects with devices through RC8 provider, clients (PCs) and a server (RC8 controller) communicates with b-CAP protocol in each connection (by AddController unit). Note that the controller name, which is the first argument of CaoWorkspace::AddController, needs to be the unique value. A duplicate controller name causes connection failure.

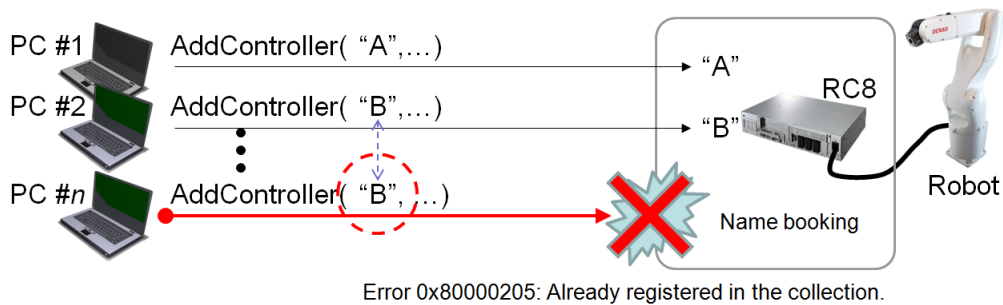

These controller names should be handled so that these do not duplicate among clients. If it is impossible, you can request the system side to issue a unique name by means of entering empty string ("") to a controller name. This automatically assigned name can be obtained by CaoController::Name property.

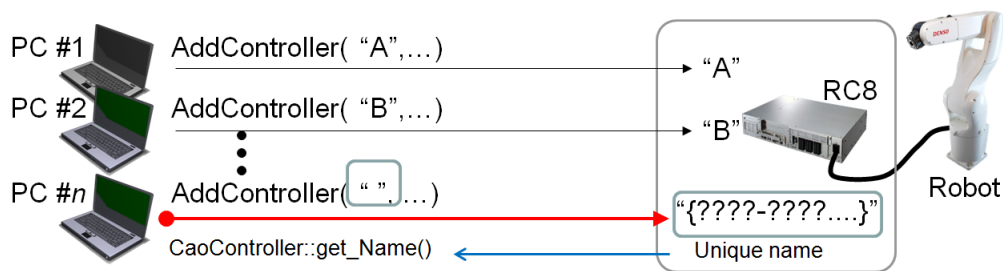

5.2.2. CaoController::AddFile method

The argument of the AddFile method of the CaoController class specifies the file name (BSTR type). The specified "File name" is a PAC program name, system reserved file name, or directory name. You can specify a directory by specifying only file path for the argument. If the path is not specified, files in the project root, which is the default directory, are specified.

Following shows the argument specification of AddFile.

Syntax AddFile(<bstrName:BSTR > [,<bstrOption:BSTR>])

bstrName : [in] File/directory name

bstrOption : [in] Option character string

Specify a directory name with a '\' symbol added to the end of it.

The option uses the following character strings.

Table 5-3 Option character string of CaoController::AddFile

Option	Meaning
@Create[=<0 to 2>]	0: bstrName is not created. An error is returned if bstrName does not exist (default). 1: bstrName is created. The existing bstrName is acquired if it already exists. 2: bstrName is created. An error is returned if the specified bstrName exists.

The table below shows a list of files.

Table 5-4 File implementation status list

	ORiN2 file name	Form	Explanation
1	*.PCS	text	PacScript source
2	*.H	text	PacScript header
3	*.PNS	text	Operation panel source

[Attention]

The CaoFile object does not support simultaneous access to a file.

Be sure to implement an exclusive file access control routine in the application.

Example Get the content of a Pro1.pcs file.

```
-----
Dim caoFI As CaoFile
Dim strText As String
```

```
Set caoFl = caoCtrl.AddFile("pro1.pcs", " ") ' Specify pro1.pcs
strText = caoFl.Value
```

5.2.3. CaoController::AddRobot method

A CaoRobot object is retrieved by calling the AddRobot method. The argument of the AddRobot method of the CaoController class specifies the robot name (BSTR type). "Robot name" specified here is any string and there is no restriction for naming. For example, you can specify AddRobot ("Robot1").

Syntax AddRobot(<bstrName:BSTR > [,<bstrOption:BSTR>])

- bstrName : [in] Robot name
- bstrOption : [in] Option character string
- ID=<Robot number>

By default, ID=0. The following IDs are available.

ID number	Robot type	Remarks
0	Master	-
1	Slave robot (the first slave robot)	Use this ID for cooperative control function only.

Example

```
Dim CaoRob as CaoRobot
Set Rob = caoCtrl.AddRobot("Robot0", "ID=0" ) 'Specify Robot0
```



Example for Cooperative control function

```
Dim MasterRobot as CaoRobot
Dim SlaveRobot as CaoRobot
Set MasterRobot = caoCtrl.AddRobot("Robot0", "ID=0" ) 'Specify Robot0
Set SlaveRobot = caoCtrl.AddRobot("Robot1", "ID=1" ) 'Use this command when slave robot is used
' in the coordinate function

MasterRobot.Move 1, "J0"
SlaveRobot.Move 1, "J1"
```

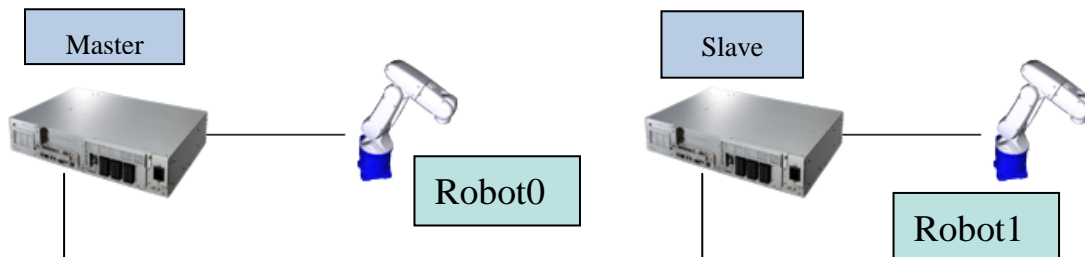

5.2.4. CaoController::AddTask method

The argument of the AddTask method of the CaoController class specifies the task name (BSTR type). "Task name" specified here specifies a PAC program name. For instance, the CaoTask object is retrieved in the expression like AddTask("pro1").

Syntax AddTask(<bstrName:BSTR > [,<bstrOption:BSTR>])

bstrName	:	[in]	Task name
bstrOption	:	[in]	Option character string (not used)

Example

```
-----  
Dim caoTsk as CaoTask  
Set caoTsk = caoCtrl.AddTask("Pro1", " ") ' Specify Pro1  
-----
```

5.2.5. CaoController::AddVariable method

The AddVariable method of this CaoController class is a method for the access to the variable. In the RC8 provider, both the user variable and the system variable can be specified for the variable name.

User variables support the following variables, i.e., RC8 controller global variables (I, F, V, P, J, D, T, S) and I/O.

The following shows the argument specifications of AddVariable.

Syntax AddVariable(<bstrName:BSTR > [,<bstrOption:BSTR>])

bstrName : [in] Variable name "<Variable name>[<Number>]"

bstrOption : [in] Option character string "<Option>"

<Variable identifier> : I, F, V, P, J, D, T, S or IO, IOB, IOW, IOD, IOF. The characters are not case-sensitive (uppercase and lowercase have the same meaning).

The I/O values are processed as follows: IO in Bits, IOB in Bytes, IOW in Words, IOD in Double Words (Long), and IOF in Float (Single).

<Number> : Variable's number specified by the identifier or "*" or "*_<Numeric value>"

The number is specified by a decimal number.

The specification of "*" is handled as the initial value of 0. The variable's number can be retrieved and changed by 'ID' property of the variable object. Specify the numeric value in *_<Numeric value> as a decimal number. Wild card for variables of the same type (*): This is an identification number that enables to specify multiple definitions, and the value has no special meaning.

"[" and "]" can be omitted.

Example 1	"i0","I[0]"	...	Specify the 0th I type variable.
Example 2	"IO128","io[128]"	...	Specify the 128th I/O variable.
Example 3	"I*","IO[*]"	...	Specify a wild card.
Example 4	"I*_1","I*_2","I*_3"	...	Specify multiple wild cards (I type variables).

When you specify a system variable, add "@" at the beginning of the variable name. All variables without "@" at the beginning of names are treated as user variables.

Refer to "5.3 Variable list" about the system variables implemented in the RC8 provider.

Example Access to the 128th I/O variable

```
Dim caoVar as CaoVariable
Set caoVar = caoCtrl.AddVariable("IO128", " ") ' Specify I/O128
caoVar.value = 1
MsgBox caoVar.Value
```

```
Dim caoVar as CaoVariable
Set caoVar = caoCtrl.AddVariable("IO*", " ") ' Specify IO* and the index in ID
caoVar.ID = 128
caoVar.value = 1
MsgBox caoVar.Value
```

5.2.6. CaoController::AddExtension method

The argument of the AddExtension method of the CaoController class specifies the extended function name (BSTR type).

Syntax <caoExt:CaoExtension object> = AddExtension (<bstrName:BSTR> [,<bstrOption:BSTR>])

bstrName : [in] Extended function name
 bstrOption : [in] Option character string (not used)
 Return value : [out] CaoExtension class object

Following is a list of available extended functions.

Table 5-5 CaoWorkspace::AddExtension extended function name list

Extended function name	Explanation
Hand<n> ²	Object for electric gripper <n> ³

Example:

```
Dim caoExt as CaoExtension
Set caoExt = caoCtrl.AddExtension( "Hand0") ' Get Hand0 object
```

² <n> specifies a board number (0 to 7).

³ Before using an electric gripper object, it is necessary to install an optional electric gripper control board and make initial settings. For details about making initial settings, refer to "Settings of the Electric Gripper" in "DENSO ROBOT USER MANUALS Controller Model:RC8 Series."

5.2.7. CaoController::get_Name property

Get the controller name specified in the AddController method of the CaoWorkspace class.

Example Display the automatically assigned controller name.

```
-----
Private caoEng As CaoEngine           ' Engine object
Private caoWs As CaoWorkspace         ' WorkSpace object
Private caoCtrl As CaoController      ' Controller object

Set caoEng = New CaoEngine
Set caoWS = caoEng.CaoWorkspaces.Item(0)
Set caoCtrl = CaoWS.AddController(" ", "CaoProv.DENSO.RC8", " ", "Server=192.168.0.1")

Debug.Print caoCtrl. Name
-----
```

5.2.8. CaoController::get_FileNames property

Get a list of file names that can be specified by the AddFile method.

Example List the file names that are below the root folder.

```
-----
Dim In%, lb%, ub%
Dim var As variant

var = caoCtrl.FileNames

lb = LBound( var )
ub = UBound( var )
For In = lb To ub
    Debug.Print Str( In ) &"=" & var( In )
Next
-----
```

5.2.9. CaoController::get_TaskNames property

Get a list of task names that can be specified by the AddTask method.

Example List task names.

```
-----
Dim In%, lb%, ub%
Dim var As variant

var = caoCtrl.TaskNames

lb = LBound( var )
ub = UBound( var )
For In = lb To ub
    Debug.print Str( In ) &"=" & var( In )
Next
-----
```

5.2.10. CaoController::get_VariableNames property

Get a list of variable names and system variable names that can be specified by the AddVariable method.

5.2.11. CaoController::Execute method

Execute a provider-specific extended command belonging to the CaoController class.

For about arguments, specify a command as a BSTR and a parameter as a VARIANT array.

Syntax [`<vntRet:VARIANT> =] Execute(<bstrCmd:BSTR > [,<vntParam:VARIANT>])`

<code>bstrCmd</code>	:	[in]	Command name
<code>vntParam</code>	:	[in]	Parameter
<code>vntRet</code>		[out]	Return value

If a method not defined in this class is called by using the runtime binding function, the Execute method is automatically called according to the following specifications:

```
vntRet = Obj.CommandName( Param1, Param2, ... )
```

↓

```
vntRet = Obj.Execute("CommandName", Array(Param1, Param2, ... ) )
```

1. The command name is passed as a BSTR string to the first argument.
2. All the parameters are passed as a VARIANT array to the second argument.

Example

```
Dim vRes as Variant
vRes = caoCtrl.Execute("ClearError" ) ' Clear error of controller
vRes = caoCtrl.ClearError()
```

The list shows available commands.

Table 5-6 List of commands of CaoController::Execute method

Category	Command name	Function	Support Version	
Error processing	ClearError	Reset an error.	1.0.0	P.59
	GetErrorDescription	Get an error string.	1.0.0	P.60

	GetCurErrorCount	Get the number of errors currently occurred.	1.0.0	P.72
	GetCurErrorInfo	Get the information of currently issued error.	1.0.0	P.72
Task control				
	KillAll	Terminate all tasks.	1.0.0	P.60
	SuspendAll	Suspend all tasks.	1.0.0	P.61
	StepStopAll	Step-stop all tasks	1.0.0	P.62
	ContinueStartAll	Continue-start all tasks.	1.0.0	P.62
	KillAllTsr	Initialized stop of all the supervisory tasks under execution.	1.0.0	P.60
	RunAllTsr	Run supervisory tasks specified by Mode.	1.0.0	P.61
Log				
	GetErrorLogCount	Get count of error log.	1.0.0	P.63
	GetErrorLog	Get data of the error.	1.0.0	P.63
	GetOprLogCount	Get count of operation log.	1.0.0	P.64
	GetOprLog	Get data of the operation.	1.0.0	P.65
Variable access				
	GetPublicValue	Read a Public variable value.	1.7.14	P.66
	SetPublicValue	Write a Public variable value.	1.7.14	P.68
Misc.				
	SysState	Get controller status.	1.4.2	P.70
	SysInfo	Get the system information of the controller.	1.7.11	P.70
	SetAllDummyIO	Set the I/Os to dummy I/Os.	1.6.5	P.72

5.2.11.1. CaoController::Execute("ClearError") command

Clear an error that occurs in the controller.

Syntax ClearError ()

Argument : None
Return value : None

Example

```
-----  
caoCtrl.Execute "ClearError"  
-----
```

5.2.11.2. CaoController::Execute("GetErrorDescription") command

Get the description of an error with the specified error code.

Syntax GetErrorDescription (<IErrCode>)

<IErrCode> : [in] Error code (VT_I4)
Return value : Error description (VT_BSTR)

Example

```
-----
Dim strDescription As String
strDescription = caoCtrl.Execute("GetErrorDescription" , &H83500003 )
-----
```

5.2.11.3. CaoController::Execute("KillAll") command

Perform initialized stop of all the running tasks.

Syntax KillAll ()

Argument : [in] Synchronizing flag(VT_I4)
0: Exit processing without waiting the stop of robots or program.
1: Exit processing after robots or program has stopped.
If the argument is omitted, 0 is assumed to be specified.
Return value : None

All the tasks are sent into an initialized stop status. However, supervisory tasks do not stop.

Example

```
-----
caoCtrl.Execute"KillAll"
-----
```

5.2.11.4. CaoController::Execute("KillAllTsr") command

Perform initialized stop of all the supervisory tasks under execution

Syntax KillAllTsr ([<ISync>])

Argument : [in] Synchronizing flag(VT_I4)
0: Exit processing without waiting the stop of supervisory tasks.
1: Exit processing after supervisory tasks has stopped.
If the argument is omitted, 0 is assumed to be specified.
Return value : None

Example

```
caoCtrl.Execute"KillAllTsr"
```

5.2.11.5. CaoController::Execute("RunAllTsr") command

Run supervisory tasks specified by Mode

Syntax RunAllTsr ([<Mode>])

Argument : [in] Mode (VT_I4)
 0: Run supervisory tasks in the root
 1: Run all the supervisory tasks
 If the argument is omitted, 0 is assumed to be specified.

Return value : None

Example

```
caoCtrl.Execute"RunAllTsr"
```

5.2.11.6. CaoController::Execute("SuspendAll") command

Suspend all the running tasks.

Syntax SuspendAll ()

Argument : [in] Synchronizing flag(VT_I4)
 0: Exit processing without waiting the stop of robots or program.
 1: Exit processing after robots or program has stopped.
 If the argument is omitted, 0 is assumed to be specified.

Return value : None

All the tasks are sent into suspended status. However, supervisory tasks do not stop.

Example

```
caoCtrl.Execute"SuspendAll"
```

5.2.11.7. CaoController::Execute("StepStopAll") command

Perform step stop of all the running tasks.

Syntax StepStopAll ()

Argument : [in] Synchronizing flag(VT_I4)
0: Exit processing without waiting the stop of robots or program.
1: Exit processing after robots or program has stopped.
If the argument is omitted, 0 is assumed to be specified.

Return value : None

Supervisory tasks do not stop.

If Synchronizing flag is 1, StepStopAll command exits the processing when the program stops before the step-stop has achieved.

Example

```
-----  
caoCtrl.Execute"StepStopAll"  
-----
```

5.2.11.8. CaoController::Execute("ContinueStartAll") command

Start all the running tasks which are being suspended.

Syntax ContinueStartAll ()

Argument : None
Return value : None

Example

```
-----  
caoCtrl.Execute"ContinueStartAll"  
-----
```

5.2.11.9. CaoController::Execute("GetErrorLogCount") command

Get count of error log.

Syntax GetErrorLogCount ()

Argument : None
Return value : Count (VT_I4)

Example

```
-----
Dim IErrCnt As Long
IErrCnt = caoCtrl.Execute("GetErrorLogCount")
-----
```

5.2.11.10. CaoController::Execute("GetErrorLog") command

Get data of the error.

Syntax GetErrorLog (<IIndex>)

<IIndex> : Index number (VT_I4) 0 to <Count>-1
Return value : Details (VT_VARIANT[VT_VARIANT|VT_ARRAY:15 elements])
[0]:Error Code (VT_I4)
[1]:Year (VT_I4)
[2]:Month (VT_I4)
[3]:Day of week (VT_I4)
[4]:Day (VT_I4)
[5]:Hour (VT_I4)
[6]:Minute (VT_I4)
[7]:Second (VT_I4)
[8]:Milliseconds (VT_I4)
[9]: Tick count of the controller [ms] (VT_I4)
[10]:Program Name (VT_BSTR)
[11]:Line Number (VT_I4)
[12]:Error Description (VT_BSTR)
[13]:Original Error Code (VT_I4)
[14]:Client ID (VT_I4)
-1:Unknown
0:System

1:TP
2:IO
3:PC
4:PAC
5:COM2
6:COM3
7:COM4

Example

```
Dim IErrCnt As Long
IErrCnt = caoCtrl.Execute("GetErrorLogCount")
Dim i As Long
For i=0 To IErrCnt-1
    vDat = caoCtrl.Execute("GetErrorLog", i)
    ' Hex(vDat(0)) Error Code
    ' vDat(12) Error Description
    ' :
Next
```

5.2.11.11. CaoController::Execute("GetOprLogCount") command

Get count of operation log.

Syntax GetOprLogCount ()

Argument	:	None
Return value	:	Count (VT_I4)

Example

```
Dim IOprCnt As Long
IOprCnt = caoCtrl.Execute("GetOprLogCount")
```

5.2.11.12. CaoController::Execute("GetOprLog") command

Get data of the operation.

Syntax GetOprLog (<IIndex>)

<IIndex>	:	Index number (VT_I4) 0 to <Count>-1
Return value	:	Details (VT_VARIANT[VT_VARIANT VT_ARRAY:12 elements])
		[0]:Error Code (VT_I4)
		[1]:Year (VT_I4)
		[2]:Month (VT_I4)
		[3]:Day of week (VT_I4)
		[4]:Day (VT_I4)
		[5]:Hour (VT_I4)
		[6]:Minute (VT_I4)
		[7]:Second (VT_I4)
		[8]:Milliseconds (VT_I4)
		[9]: Tick count of the controller [ms] (VT_I4)
		[10]:Client ID (VT_I4)
		-1:Unknown
		0:System
		1:TP
		2:IO
		3:PC
		4:PAC
		5:COM2
		6:COM3
		7:COM4
		[11]:Operation description (VT_BSTR)

Example

```

Dim IOprCnt As Long
IOprCnt = caoCtrl.Execute("GetOprLogCount")
Dim i As Long
For i=0 To IOprCnt-1
    vDat = caoCtrl.Execute("GetOprLog", i)
    ' Hex(vDat(0)) Operation code
    ' vDat(11) Operation description
    ' :
Next

```

5.2.11.13. CaoController::Execute("GetPublicValue") command

Read a Public variable value.

Syntax GetPublicValue (<bstrTask> , <bstrName>[, <lIndex1>, <lIndex2>, ...])

<bstrTask>	:	Task name (VT_BSTR)
<bstrName>	:	Variable name (VT_BSTR)
<lIndex(n)>	:	Index numbers for each dimension (VT_I4)
<lIndex(n+1)>	:	Assume that "Public pbIArrays(1,2,3) As Long" is specified.
...	:	Specifying (bstrTask, bstrName, 1, 2, 2) will read one element of pbIArrays(1, 2, 2). If this item is omitted when the target is one dimensional array, the array will be read as a batch.
Return value	:	Values of Public variable

Read a Public variable value in the specified task.

If a Public variable is an array, specifying index number of each dimension will read a value in the specified array.

If an index number is omitted when a Public variable is one-dimensional array, whole elements in the array will be read as a batch.

V type: Read as a F-type (VT_R4) array with three elements.

[0]X, [1]Y, [2]Z

P type: Read as a F-type (VT_R4) array with seven elements.

[0]X, [1]Y, [2]Z, [3]Rx, [4]Ry, [5]Rz, [6]Fig

J type: Read as a F-type (VT_R4) array with eight elements.

[0]J1, [1]J2, [2]J3, [3]J4, [4]J5, [5]J6, [6]J7, [7]J8

T type: Read as a F-type (VT_R4) array with ten elements.

[0]X, [1]Y, [2]Z, [3]Ox, [4]Oy, [5]Oz, [6]Ax, [7]Ay, [8]Az, [9]Fig

[Attention]

A batch reading of a Public variable with two or more dimensional arrays is not supported.

If a batch reading is carried out for a multi-dimensional array, only the elements in one-dimensional array will be read as a batch.

V-, P-, J-, and T-type can be read only when a target Public variable is a Scala variable.

Example

PacScript – Pro1.pcs

```
Public pbIValue As Long
Public pbIArrays(1, 2, 3) As Long
Public pbIArray(2) As Long
Public pbPValue As Position
```

```
Sub Main
```

```
End Sub
```

VisualBasic – Reading Variable

```
Dim vParam As Variant
Dim iVal As Long

vParam = Array("Pro1", "pbIValue")
iVal = caoCtrl.Execute("GetPublicValue", vParam)
```

VisualBasic – Reading one element of array

```
Dim vParam As Variant
Dim iVal As Long

vParam = Array("Pro1", "pbIArrays", 1, 2, 2)
iVal = caoCtrl.Execute("GetPublicValue", vParam)
```

VisualBasic – Reading one dimensional array as a batch

```
Dim vParam As Variant
Dim vArray As Variant

vParam = Array("Pro1", "pbIArray")
vArray = caoCtrl.Execute("GetPublicValue", vParam)
```

VisualBasic – Reading P-type variable

```
Dim vParam As Variant
Dim vVal As Variant

vParam = Array("Pro1", "pbPValue")
vVal = caoCtrl.Execute("GetPublicValue", vParam)
```

5.2.11.14. CaoController::Execute("SetPublicValue") command

Write a Public variable value.

Syntax	SetPublicValue (<vValue>, <bstrTask> , <bstrName>[, <IIndex1>, <IIndex2>, ...])
	<vValue> : Value of Public variable to be written (given value)
	<bstrTask> : Task name (VT_BSTR)
	<bstrName> : Variable name (VT_BSTR)
	<IIndex(n)> : Index number for each dimension (VT_I4)
	<IIndex(n+1)> Assume that "Public pbIArrays(1,2,3) As Long" is specified.
	... Specifying(vValue, bstrTask, bstrName, 1, 2, 2) will write one
	element of pbIArrays(1, 2, 2). If this item is omitted when the target
	is one dimensional array, the array will be written as a batch.
	Return value : None

Write a Public variable value in the specified task.

If a Public variable is an array, specifying index number of each dimension will write a value in the specified array.

If an index number is omitted when a Public variable is one-dimensional array, whole elements in the array will be written as a batch.

V type: Write as a F-type (VT_R4) array with three elements.

[0]X, [1]Y, [2]Z

P type: Write as a F-type (VT_R4) array with seven elements

[0]X, [1]Y, [2]Z, [3]Rx, [4]Ry, [5]Rz, [6]Fig

J type: Write as a F-type (VT_R4) array with eight elements

[0]J1, [1]J2, [2]J3, [3]J4, [4]J5, [5]J6, [6]J7, [7]J8

T type: Write as a F-type (VT_R4) array with ten elements.

[0]X, [1]Y, [2]Z, [3]Ox, [4]Oy, [5]Oz, [6]Ax, [7]Ay, [8]Az, [9]Fig

[Attention]

A batch writing of a Public variable with two or more dimensional arrays is not supported.

If a batch writing is carried out for a multi-dimensional array, an error occurs.

A batch writing of a Public variable with one-dimensional array is available only when the number of elements and the element type are the same in the source array and the destination array.

V-, P-, J-, and T-type can be written only when a target Public variable is a Scala variable.

Example

PacScript – Pro1.pcs

```
Public pblValue As Long
Public pblArrays(1, 2, 3) As Long
Public pblArray(2) As Long
Public pbPValue As Position
```

```
Sub Main
```

```
End Sub
```

VisualBasic – Writing Variable

```
Dim iVal As Long
Dim vParam As Variant

iVal = 1234
vParam = Array(iVal, "Pro1", "pblValue")
caoCtrl.Execute "SetPublicValue", vParam
```

VisualBasic – Writing one element of array

```
Dim iVal As Long
Dim vParam As Variant

iVal = 1234
vParam = Array(iVal, "Pro1", "pblArrays", 1, 2, 2)
caoCtrl.Execute "SetPublicValue", vParam
```

VisualBasic – Writing one dimensional array as a batch

```
Dim i As Long
Dim iArray(2) As Long
Dim vParam As Variant

For i = 0 To 2
    iArray(i) = i
Next i
vParam = Array(iArray, "Pro1", "pblArray")
caoCtrl.Execute "SetPublicValue", vParam
```

VisualBasic – Writing P-type variable

```
Dim fVals(6) As Single
Dim vParam As Variant

fVals(0) = 1.0
fVals(1) = 2.0
fVals(2) = 3.0
fVals(3) = 1.0
fVals(4) = 2.0
```

```
fVals(5) = 3.0
fVals(6) = -1
vParam = Array(fVals, "Pro1", "pbPValue")
caoCtrl.Execute "SetPublicValue", vParam
```

5.2.11.15. CaoController::Execute("SysState") command

Return the controller status.

This command corresponds to SYSSTATE instruction of PacScript language.

Syntax SysState ()

Argument : None
Return value : Controller status (VT_I4)

Example

```
Dim state as long
State = caoCtrl.Execute("SysState")
```

5.2.11.16. CaoController::Execute("SysInfo") command

Return the system information of the controller

This corresponds to the SysInfo command of PacScript.

Syntax SysInfo (<IIndex>)

<IIndex > : Index number (VT_I4)
Return value : [out] System information of the controller

Index number	System information	Data type
0	Manufacturing number (serial number of the controller)	String type
1	MAC address of built-in network card in the controller	String type
2	Pendant connection state 0: Not connected 1: Teach pendant is connected 2: Mini-pendant is connected	Integer type
3	Global variables information The numbers from 0 to 7 correspond to the variable types as shown below. 0: I type 1: F type	Integer type array

	2: D type 3: V type 4: P type 5: J type 6: T type 7: S type	
4	CPU information 0: Not identified (Virtual environment) 2: ATOM 5: i7	Integer type
5	Login user level 1000: Operator 2000: Programmer 3000: Maintainer 3001 or more: Reserved for System	Integer type
6	Supervisory tasks status -1: Running 0: Not running	Integer type
7	TP panel display -1: Displayed 0: Not displayed	Integer type
8	Total operation (min.)	Integer type
9	Total running (min.)	Integer type
10	Cumulative operation (min.)	Integer type
11	Cumulative running (min.)	Integer type
12	Operation (min.)	Integer type
13	Running (min.)	Integer type
14	Motor-ON count	Integer type
15	Encoder battery maintenance date -1: Maintenance date has passed 0: Maintenance date has not arrived yet	Integer type
16	Controller battery maintenance date -1: Maintenance date has passed 0: Maintenance date has not arrived yet	Integer type

Example

```
Dim sysinfo as long
sysinfo = caoCtrl.Execute("SysInfo",0)
```

5.2.11.17. CaoController::Execute("SetAllDummyIO") command

Set the I/Os to dummy I/Os.

Syntax SetAllDummyIO (<IMode>)

<IMode> : Number (VT_I4)

Return value : none

Index number	Robot information
0	Reset all dummy IOs
1	Set user IOs to dummy IOs
2	Set system IOs to dummy IOs
3	Set both user and system IOs to dummy IOs

Example

```
g_caoCtrl.Execute "SetAllDummyIO", 0 'Reset all dummy IOs
```

5.2.11.18. CaoController::Execute("GetCurErrorCount") command

Return the number of errors currently occurred. The number of error will be 0 if error is cleared.

Syntax GetCurErrorCount ()

Argument : none

Return value : [out] The number of errors being occurred [VT_I4]

Example

```
Dim ErrCount as long
ErrCount = caoCtrl.Execute("GetCurErrorCount")
```

5.2.11.19. CaoController::Execute("GetCurErrorInfo") command

Return the information of currently issued error. Number zero (0) in Index represents the latest error.

Syntax GetCurErrorInfo (<IIndex>)

- < lIndex> : Index number
- Return value : [out] Information of the currently issued error.
 - 1: Error code (VT_I4)
 - 2: Error message (VT_BSTR)
 - 3: Sub code (VT_I4)
 - 4: File ID + line number (VT_I4)
 - 5: Program name (VT_BSTR)
 - 6: Line number (VT_I4)
 - 7: File ID (VT_I4)

A return value 4 consists of (((file ID << 20) & 0xFFFF0000) | (line number & 0x000FFFFF)).

Example

```
Dim Errinfo as Variant
Errinfo = caoCtrl.Execute("GetCurErrorInfo",0)
```

5.2.12. CaoController::Execute method (dedicated for COBOTTA)

Executes the extension command unique to the provider, which belongs to CaoController class.
The list shows available commands.

Table 5-7 List of commands of CaoController::Execute method (dedicated for COBOTTA)

Category	Command name	Function	Support Version
Robot			
Status/Value			
Obtainment			
	GetCCSConnection	Get the connection condition of the wireless tablet.	2.8.0 P.75
	GetDirectMode	Get the direct mode state.	2.8.0 P.75
Robot			
Others			
	ManualResetPreparation	Confirm safety-related command (MotionPreapration, ErrorReset) sending.	2.8.0 P.75
Electric Gripper			

Motion				
HandChuck	Perform the workpiece gripping movement.	2.8.0	P.76	
HandUnChuck	Move from the gripping state to the specified position.	2.8.0	P.77	
HandMoveA	Move the fingers to an absolute position.	2.8.0	P.77	
HandMoveR	Move the fingers to a relative position.	2.8.0	P.77	
HandMoveH	Perform the gripping motion, while traveling at a constant speed.	2.8.0	P.78	
HandMoveAH	Perform the absolute position gripping motion with acceleration/deceleration.	2.8.0	P.78	
HandMoveRH	Perform the relative position gripping motion with acceleration/deceleration.	2.8.0	P.79	
HandMoveZH	Perform the gripping motion, while traveling at a constant speed with zoning.	2.8.0	P.79	
HandStop	Stop the gripper motion.	2.8.0	P.80	
HandMoveVH	Start suction or blower operation of an electric vacuum generator.	2.8.0	P.82	
Electric Gripper				
Status/Value	Obtainment			
HandBusyState	Get the gripper's busy status.	2.8.0	P.80	
HandHoldState	Get the gripping status of the gripper.	2.8.0	P.81	
HandInposState	Get whether the fingers of the gripper are at the target position.	2.8.0	P.81	
HandZonState	Get the status on whether the fingers of the gripper are within the setting range.	2.8.0	P.82	
HandCurPos	Get the current position of the fingers of the gripper.	2.8.0	P.82	
HandCurPressure	Get the pressure sensor value of electric vacuum generator.	2.8.0	P.83	
HandCurLoad	Get the load ratio of electric vacuum generator.	2.8.0	P.83	
HandSetDetectThreshold	Set the threshold value for the suction detection of an electric vacuum generator.	2.8.0	P.84	

5.2.12.1. CaoController::Execute ("GetCCSConnection") command

Returns the connection condition of the wireless tablet.

Format GetCCSConnection()

Argument : None
 Return value : [out] Connection condition of the wireless tablet (VT_I4)
 1: Connecting to the wireless tablet
 0: Not connecting to the wireless tablet

Example

```
Dim IVal As Long
IVal = caoCtrl.Execute("GetCCSConnection")
```

5.2.12.2. CaoController::Execute("GetDirectMode") command

Get the direct mode state.

Format GetDirectMode()

Argument : None
 Return value : [out] The direct mode state
 0. Other than direct mode
 2. Direct mode

Example

```
Dim IMode As Long
IMode = caoCtrl.Execute("GetDirectMode")
```

5.2.12.3. CaoController::Execute ("ManualResetPreparation") command

When you control your COBOTTA by any means other than RC8 provider (such as to control your COBOTTA directly from b-CAP), before sending safety-related commands (e.g; motion preparation, error reset) from the control means, send this command to confirm if the safety-related command is intentionally sent.

If you don't send this command beforehand, "83500372" error will occur.

Table 5-8 Comamnds that require ManualResetPreparation sending beforehand

Command	Function	

MotionPreparation	To automatically execute Motion preparation.	P.168
ClearError	To reset an error	P.59
@ERROR_CODE	To obtain and set an error code. This must be sent before setting 0 (ErrorReset).	P.189

Format ManualResetPreparation

Argument : None

Return value : None

Example

'Clear the emergency stop and protective stop

'Sending confirmation before error clear

```
caoRobot.Execute "ManualResetPreparation"
```

'Reset an error

```
caoCtrl.Execute "ClearError"
```

'If motion preparation has not been completed, do it.

```
Dim vbState
```

```
vbState = caoRobot.Execute("GetMotionPreparationState")
```

```
If vbState <> True Then
```

```
    'Sending confirmation before executing Motion Preparation
```

```
    caoRobot.Execute "ManualResetPreparation"
```

```
    caoRobot.Execute "MotionPreparation"
```

```
End If
```

5.2.12.4. CaoController::Execute ("HandChuck") command

This is a command for the COBOTTA end-effector. This command performs the workpiece gripping movement according to the specified point data setting. When an electric vacuum generator is used, this command starts suction operation according to the specified point data setting.

Format HandChuck <IPointNo:LONG> [, <bstrNext:BSTR> or <bstrDetectOn:BSTR >]

<IPointNo> : [in] Point number

<bstrNext:BSTR> : [in] NEXT: Asynchronous execution option (Only for gripper)
 <bstrDetectOn:BSTR> : [in] DetectOn: Detect gripping option (Only for gripper)

Example

```
caoCtrl.Execute("HandChuck",Array(0, "Next"))
```

5.2.12.5. CaoController::Execute("HandUnChuck") command

This is a command for the COBOTTA end-effector. This command moves from the gripping state to the specified position according to the specified point data mode. When an electric vacuum generator is used, this command starts blower operation or stops the operation according to the specified point data mode.

Format HandUnChuck <lPointNo:LONG> [, <bstrNext:BSTR>]

<lPointNo> : [in] Point number
 <bstrNext:BSTR> : [in] NEXT: Asynchronous execution option (Only for gripper)

Example

```
caoCtrl.Execute "HandUnChuck", Array(1, "Next")
```

5.2.12.6. CaoController::Execute("HandMoveA") command

This is a command for the COBOTTA end-effector. This command moves the fingers to an absolute position. This command is only for gripper.

Format HandMoveA <dblPos:DOUBLE>, <sngSpeed:SINGLE > [, <bstrNext:BSTR>]

<dblPos> : [in] Finger position after the move (mm)
 <sngSpeed> : [in] Target speed (%)
 <bstrNext:BSTR> : [in] NEXT: Asynchronous execution option

使用例

```
caoCtrl.Execute "HandMoveA", Array(29.5, 100)
```

5.2.12.7. CaoController::Execute("HandMoveR") command

This is a command for the COBOTTA end-effector. This command moves the fingers to a relative position.

This command is only for gripper.



HandMoveR <dblPos:DOUBLE>, <sngSpeed:SINGLE > [, <bstrNext:BSTR>]

<dblPos> : [in] Travel distance from the current finger position (mm)

<sngSpeed> : [in] Target speed (%)

<bstrNext:BSTR> : [in] NEXT: Asynchronous execution option



```
caoCtrl.Execute "HandMoveR", Array(-5.5, 100)
```

5.2.12.8. CaoController::Execute("HandMoveH") command

This is a command for the COBOTTA end-effector. This command performs the gripping motion, while traveling at a constant speed. This command is only for gripper.



HandMoveH <dblForce:DOUBLE>, <bDirection:BOOL >
[, <bstrNext:BSTR> or <bstrDetectOn:BSTR >]

<dblForce> : [in] Force (N)

<bDirection> : [in] Motion direction

True: Closing direction

False: Opening direction

<bstrNext:BSTR> : [in] NEXT: Asynchronous execution option

<bstrDetectOn:BSTR> : [in] DetectOn: Detect gripping option

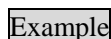

```
caoCtrl.Execute "HandMoveH", Array(20, True, "Next")
caoCtrl.Execute "HandMoveA", Array(30, 100)
caoCtrl.Execute "HandMoveH", Array(20, True, "DetectOn")
```

5.2.12.9. CaoController::Execute("HandMoveAH") command

This is a command for the COBOTTA end-effector. This command performs the absolute position gripping motion with acceleration/deceleration. This command is only for gripper.



HandMoveAH <dblPos:DOUBLE>, <sngSpeed:SINGLE >,
<dblForce:DOUBLE>[, <bstrNext:BSTR> or <bstrDetectOn:BSTR >]

<dblPos>	:	[in] Position to move to the gripping motion (mm)
<sngSpeed>	:	[in] Target speed (%)
<dblForce>	:	[in] Force (N)
<bstrNext:BSTRT>	:	[in] NEXT: Asynchronous execution option
<bstrDetectOn:BSTRT>	:	[in] DetectOn: Detect gripping option

Example

```
caoCtrl.Execute "HandMoveAH", Array(25, 100, 20, "Next")
```

5.2.12.10. CaoController::Execute("HandMoveRH") command

This is a command for the COBOTTA end-effector. This command performs the relative position gripping motion with acceleration/deceleration. This command is only for gripper.

Format HandMoveRH <dblPos:DOUBLE>, < sngSpeed:SINGLE >,
<dblForce:DOUBLE>[, < bstrNext:BSTRT> or < bstrDetectOn:BSTRT >]

<dblPos>	:	[in] Travel distance from the current finger position to the position moving to the gripping motion (mm)
<sngSpeed>	:	[in] Target speed (%)
<dblForce>	:	[in] Force (N)
<bstrNext:BSTRT>	:	[in] NEXT: Asynchronous execution option
<bstrDetectOn:BSTRT>	:	[in] DetectOn: Detect gripping option

Format

```
caoCtrl.Execute "HandMoveAH", Array(-10, 100, 20, "Next")
```

5.2.12.11. CaoController::Execute("HandMoveZH") command

This is a command for the COBOTTA end-effector. This command performs the gripping motion, while traveling at a constant speed with zoning. This command is only for gripper.

Format HandMoveZH <dblZonPos1:DOUBLE>, < dblZonPos2:DOUBLE >,
<dblForce:DOUBLE>, <bDirection:BOOL >
[, < bstrNext:BSTRT> or < bstrDetectOn:BSTRT >]

<dblZonPos1>	:	[in] ZON area 1
--------------	---	-----------------

<dblZonPos2>	:	[in] ZON area 2
<dblForce>	:	[in] Force (N)
<bDirection>	:	[in] Motion direction
		True: Closing direction
		False: Opening direction
<bstrNext:BSTR>	:	[in]NEXT: Asynchronous execution option
<bstrDetectOn:BSTR>	:	[in] DetectOn: Detect gripping option

Example

```
caoCtrl.Execute "HandMoveZH", Array(9.5, 10.5, 20, True, "Next")
```

5.2.12.12. CaoController::Execute("HandStop") command

This is a command for the COBOTTA end-effector. This command stops the gripper motion. When this command is executed while an electric gripper is moving, the gripper's motion decelerates and stops in that position. When an electric vacuum generator is used, it stops suction or blower operation of an electric vacuum generator.

Format HandStop

Example

```
caoCtrl.Execute "HandStop"
```

5.2.12.13. CaoController::Execute("HandBusyState") command

This is a command for the COBOTTA end-effector. This command returns the COBOTTA end-effector's busy status.

Format HandBusyState

戻り値	:	[out] Motion state (VT_BOOL)
		True: In motion
		False: Not in motion Command state

Example

```
Dim vntBusy as Variant
vntBusy = caoCtrl.Execute("HandBusyState")
If vntBusy = True Then
```

```
caoCtrl.Execute "HandStop"
End If
```

5.2.12.14. CaoController::Execute("HandHoldState") command

This is a command for the COBOTTA end-effector. This command returns the gripping status of the gripper. If an electric vacuum generator is used, this command returns the suction state of a workpiece.

Format HandHoldState

Return value : [out] Gripping status (VT_BOOL)
 True: Gripping
 False: Not gripping

Example

```
Dim vntHold As Variant, vntBusy As Variant
vntHold = False
vntBusy = True

caoCtrl.Execute "HandMoveH", Array(20, True, "Next")
Do
  vntHold = caoCtrl.Execute("HandHoldState")
  vntBusy = caoCtrl.Execute("HandBusyState")
  Sleep(100)
Loop Until (vntHold = True) Or (vntBusy = False)

caoCtrl.Execute "HandStop"
```

5.2.12.15. CaoController::Execute("HandInposState") command

This is a command for the COBOTTA end-effector. This command returns whether the fingers of the gripper are at the target position. This command is only for gripper.

Format HandInposState

Return value : [out] Target state (VT_BOOL)
 True: At the target position
 False: Not at the target position

Example

```
Dim vntInpos as Variant

caoCtrl.Execute "HandMoveA", Array(29.5, 100, "Next")
Do
  Sleep(100)
```

```
vntInpos = caoCtrl.Execute("HandInposState")
Loop Until vntInpos = True
```

5.2.12.16. CaoController::Execute("HandZonState") command

This is a command for the COBOTTA end-effector. This command returns the status on whether the fingers of the gripper are within the setting range. This command is only for gripper.

Format HandZonState

戻り値 : [out] Zone state (VT_BOOL)
 True: Within the range
 False: Out of the range

Example

```
caoCtrl.Execute "HandMoveZH", Array(9.5, 10.5, 20, True)

Dim vntZon as Variant
vntZon = caoCtrl.Execute("HandZonState")
```

5.2.12.17. CaoController::Execute("HandCurPos") command

This is a command for the COBOTTA end-effector. This command returns the current position of the fingers of the gripper. This command is only for gripper.

Format HandCurPos

Return value : [out] Current position (VT_R8)

Example

```
Dim dblPos As Double
dblPos = caoCtrl.Execute("HandCurPos")
```

5.2.12.18. CaoController::Execute("HandMoveVH") command

This is a command for the COBOTTA end-effector. To start suction or blower operation of an electric vacuum generator.

Format HandMoveVH(<sngPower :SINGLE>,<bDirection:BOOL>[, <dThreshold:DOUBLE>])

< sngPower > : [in] Suction pressure [40 to 100] [%]

<bDirection>	:	[in] Motion direction True: Suction direction False: Blower direction
< dThreshold >	:	[in] Suction detection threshold value [kPa] Option. Specify the threshold value to determine if a workpiece is gripped with a vacuum generator

Example

```
caoCtrl.Execute "HandMoveVH", Array(100, True)
```

5.2.12.19. CaoController::Execute("HandCurPressure") command

This is a command for the COBOTTA end-effector. This command returns the pressure sensor value of electric vacuum generator.

Format HandCurPressure

Return value : [out] Current pressure sensor value (VT_R8)

Example

```
Dim dbIPos As Double
dbIPos = caoCtrl.Execute("HandCurPressure")
```

5.2.12.20. CaoController::Execute("HandCurLoad") command

This is a command for the COBOTTA end-effector. This command returns the load ratio of electric vacuum generator.

Format HandCurLoad

Return value : [out] Current load ratio (VT_R8)

Example

```
Dim dbILoad as Double
dbILoad = caoCtrl.Execute("HandCurLoad")
```

5.2.12.21. CaoController::Execute("HandSetDetectThreshold") command

This is a command for the COBOTTA end-effector. This command set the threshold value for the suction detection of an electric vacuum generator.

Format HandSetDetectThreshold(<dThreshold :DOUBLE>)

< dThreshold > : [in] Suction detection threshold value [kPa]

Specify the threshold value to determine if a workpiece is gripped with a vacuum generator

Example

```
caoCtrl.Execute "HandSetDetectThreshold", -10
```

5.2.13. CaoFile::AddFile method

Create a file object in the same way as 5.2.2. The file path corresponding to the created CaoFile object is "<Path of the parent object>/<File name specified in AddFile>".

Example Display the size of Pro1.pcs file in the User folder.

```
Dim caoFIDir As CaoFile
Set caoFIDir = caoCtrl.AddFile("User\", " " ) ' Specify User folder
Dim caoFI As CaoFile
Set caoFI = caoFIDir.AddFile("Pro1.pcs" ) ' Specify User\Pro1.pcs file

Debug.Print caoFI.Size
```

5.2.14. CaoFile::AddVariable method

The argument of the AddVariable method of the CaoFile class specifies the system variable name.

Refer to Table 5-19 for the list of implemented system variables.

Example Get the CRC of the Pro1.pcs file.

```
Dim caoFI As CaoFile
Set caoFI = caoCtrl.AddFile("ro1.pcs")

Dim caoCrc As CaoVariable
Set caoCrc = caoFI.AddVariable("CRC")

Debug.Print caoCrc.Value ' Display CRC of Pro1.pcs
```

5.2.15. CaoFile::get_VariableNames property

Get a list of variable names and system variable names that can be specified by the AddVariable method.

5.2.16. CaoFile::get_FileNames property

This can be executed only when the path corresponding to the object is a directory.

Executing it gets a list of file names in the directory.

5.2.17. CaoFile::get_Size property

Get the size of the file corresponding to the object

Example Get the size of the Pro1.pcs file.

```
-----  
Dim caoFI As CaoFile  
Set caoFI = caoCtrl.AddFile("ro1.pcs")  
  
Debug.Print caoFI.Size ' Display size of Pro1.pcs  
-----
```

5.2.18. CaoFile::get_Value property

Get the contents of the file corresponding to the object.

Example Get the contents of Pro1.pcs file.

```
-----
Dim caoFl As CaoFile
Set caoFl = caoCtrl.AddFile ("Pro1.pcs")

Debug.Print caoFl.Value ' Display contents of Pro1.pcs
-----
```

5.2.19. CaoFile::put_Value property

Set the contents of the file corresponding to the object.

5.2.20. CaoRobot::Accelerate method

Set the internal acceleration and deceleration ratio of the robot.

This method corresponds to ACCEL and JACCEL instructions of PacScript language.

This method is not available when a license key of b-CAP Slave is added and the robot is controlled by a client as a b-CAP SlaveMode.

The following shows the argument specifications of Accelerate.

Syntax Accelerate <lAxis:LONG >, <fAccel:FLOAT> [,<fDecel:FLOAT>]

lAxis	:	[in]	Axis number -1: Tool accel (ACCEL), 0: All axes (JACCEL)
fAccel	:	[in]	Acceleration (-1: keep current setting)
fDecel	:	[in]	Deceleration (-1: keep current setting)

Example

```
-----
Accelerate 0, 50.0, -1 ' Acceleration = 50%, deceleration = no change
Accelerate 0, -1, 60.0 ' Acceleration = no change, deceleration = 60%
-----
```

5.2.21. CaoRobot::AddVariable method

The argument of the AddVariable method of the CaoRobot class specifies the system variable name.

Refer to Table 5-17 for the list of implemented system variables.

Example Refer to the current robot position (P type).

```
-----  
Dim caoRob As CaoRobot  
Set caoRob = caoCtrl.AddRobot("Arm0")  
  
Dim caoCurPos As CaoVariable  
Set caoCurPos = caoRob.AddVariable("@CURRENT_POSITION")  
  
Dim vVal As Variant  
vVal = caoCurPos.Value  
MsgBox vVal(0) & "," & vVal(1) & "," & vVal(2) ' Display X, Y, and Z  
-----
```

5.2.22. CaoRobot::get_VariableNames property

Get a list of variable names and system variable names that can be specified by the AddVariable method.

5.2.23. CaoRobot::Halt method

Stop the robot motion.

A runtime error occurs if a task in the RC8 controller has robot control authority (when Takearm has been executed). Use the CaoTask::Stop method to control the stop of a task.

5.2.24. CaoRobot::Change method

Change the tool/user coordinate system of the robot.

This method corresponds to CHANGETOOL and CHANGEWORK instructions of PacScript language.

This method is not available when a license key of b-CAP Slave is added and the robot is controlled by a client as a b-CAP SlaveMode.

The following shows the argument specifications of Change.

Syntax Change <bstrName:BSTR>

bstrName : [in] For CHANGETOOL= "Tool<Number>"
For CHANGEWORK= "Work<Number>"

<Number> : Numerical value expressed by decimal number (default: 0)

Example

```
-----  
Dim caoRob As CaoRobot  
Set caoRob = caoCtrl.AddRobot("Arm0")  
  
caoRob.Execute"TakeArm", Array(0, 0)  
  
caoRob.Change"Tool1"      ' Change to Tool1  
caoRob.Change"Work1"     ' Change to Work1  
caoRob.Move 1,"P10"  
  
caoRob.Execute"GiveArm"  
-----
```

5.2.25. CaoRobot::Drive method

This method is not supported directly in this provider.

Instead, use "DriveEx" or "DriveAEx" command of CaoRobot::Execute that can operate two or more axes all at once.

5.2.26. CaoRobot::Move method

Move the robot to the specified coordinates. This method corresponds to MOVE instruction of PacScript language. The following shows the argument specifications of Move.

Syntax Move <lComp:LONG >, <vntPose:POSEDATA> [, <vntPose:POSEDATA>...] [, <bstrOpt:BSTR>]

lComp	:	[in]	Interpolation 1:MOVE P,... , 2:MOVE L,... , 3:MOVE C,... , 4:MOVE S,...
vntPose	:	[in]	Pose data (POSEDATA type)
bstrOpt	:	[in]	Motion option [SPEED=n][,ACCEL=n][,DECEL=n][,TIME=n][,NEXT] SPEED (S): Specify the movement speed. The meaning is the same as the SPEED statement. ACCEL: Specify the acceleration. The meaning is the same as the ACCEL statement. DECEL: Specify the deceleration. The meaning is the same as the DECEL statement. TIME: Specify the time to activate the motion. NEXT: Asynchronous execution option.

Refer to " Appendix B. POSEDATA Type Definition" for the POSEDATA type.

The form and the meaning when the character string is specified by the POSEDATA type are as follows.

In case of VT_BSTR type (string)

- If Comp = 1, 2
" [<@pass start displacement>] <Pose> [<Extended-joints>]"
ex. "P1", "@P T100", "@E J520"
- If Comp = 3
"<Pose 1>, [<@pass start displacement>] <Pose 2> [<Extended-joints>]"
- *** Pose 1 and Pose 2 need to be the same variable type. *** ***
ex. "P1,@E P2", "T100,@P T101"
- If Comp = 4
" [<@pass start displacement>] <Free curve trajectory number> [<Extended-joints>]"
ex. "1", "@P 20", "@E 5"

- <Free curve trajectory number> : A decimal number (spline curve number 1 to 20)
- <Pose> : "<Variable type><Variable number>" or "[<Variable type>] (<Element 1>,<Element 2>,...)"
- <Variable type> : One of characters 'P', 'T' and 'J'
 'P' is assumed to be specified if the variable type is omitted in the specification of an element (raw value).
- <Number> : A decimal number
- <Element n> : An element of either of variable types 'P', 'T', and 'J'

P type = P(<x>,<y>,<z>,<rx>,<ry>,<rz>,<fig>)

J type = J(<j1>,<j2>,<j3>,<j4>,<j5>,<j6>,<j7>,<j8>)

T type = T(<x>,<y>,<z>,<ox>,<oy>,<oz>,<ax>,<ay>,<az>,<fig>)

[Note] For 4-axis robot, T element of P type variable corresponds to <rz>. <rx> and <ry> are not used.

- <@pass start displacement> : "@0", "@P", "@E ", " "@< Value >" or "@A<Value>"

- <Extended-joints> : The syntax of an extended-joints option is shown below.⁴
 (Specify the extended-joints option after a pose data and a blank.)

"EX((<JointNumber1>, <RelativeDistance1>)[,
 (<JointNumber2>,<RelativeDistance2>)...])

or

"EX((<JointNumber1>, <AxisCoordinates1>)[,
 (<JointNumber2>,<AxisCoordinates2>)...])

Example 1	Move 1,"@P P1" ,"NEXT"	‘ MOVE P, @P P1, NEXT
Example 2	Move 3,"P1,@E P2"	‘ MOVE C, P1,@E P2
Example 3	Move 2,"@0 P(307.1856,-157.8244,107.0714,160,0,0,1)"	‘ MOVE L,@0 P(307.1856,-157.8244,107.0714,160,0,0,1)
Example 4	Move 4,"@E 2"	‘ MOVE S, @E 2
Example 5	Move 1,"@P P10 EX((7, 30.5))" ,"NEXT"	‘ MOVE P, @P P10 EX((7,30.5)), NEXT

⁴ To use the extended joint option, define extended joint related settings (e.g. arm group definition) on the controller, and use TakeArm command to select an arm group for controlled extended joint.

Example 6 Move 2,"@E P20 EXA((7, 30.8), (8, 90.5)) 'MOVE L, @E P20 EXA((7, 30.8), (8, 90.5))"

Example 7 Move 1,"P1,@A[50] P2" ' MOVE P, P1,@A[50] P2

This method is not available when a license key of b-CAP Slave is added and the robot is controlled by a client as a b-CAP SlaveMode.

The following table shows the PacScript MOVE commands supported by Move method.

Table 5-9 List of Move commands

Division	PAC command	Move method
MOVE P,...	MOVE P, P<n1> MOVE P, @P P<n1> MOVE P, @E P<n1> MOVE P, T<n1> MOVE P, @P T<n1> MOVE P, @E T<n1> MOVE P, J<n1> MOVE P, @P J<n1> MOVE P, @E J<n1>	Move 1,"P<n1>" Move 1,"@P P<n1>" Move 1,"@E P<n1>" Move 1,"T<n1>" Move 1,"@P T<n1>" Move 1,"@E T<n1>" Move 1,"J<n1>" Move 1,"@P J<n1>" Move 1,"@E J<n1>"
MOVE L,...	MOVE L, P<n1> MOVE L, @P P<n1> MOVE L, @E P<n1> MOVE L, T<n1> MOVE L, @P T<n1> MOVE L, @E T<n1> MOVE L, J<n1> MOVE L, @P J<n1> MOVE L, @E J<n1>	Move 2,"P<n1>" Move 2,"@P P<n1>" Move 2,"@E P<n1>" Move 2,"T<n1>" Move 2,"@P T<n1>" Move 2,"@E T<n1>" Move 2,"J<n1>" Move 2,"@P J<n1>" Move 2,"@E J<n1>"
MOVE C,...	MOVE C, P<n1>, P<n2> MOVE C, P<n1>, @P P<n2> MOVE C, P<n1>, @E P<n2> MOVE C, T<n1>, T<n2> MOVE C, T<n1>, @P T<n2> MOVE C, T<n1>, @E T<n2> MOVE C, J<n1>, J<n2> MOVE C, J<n1>, @P J<n2> MOVE C, J<n1>, @E J<n2>	Move 3,"P<n1>, P<n2>" Move 3,"P<n1>, @P P<n2>" Move 3,"P<n1>, @E P<n2>" Move 3,"T<n1>, T<n2>" Move 3,"T<n1>, @P T<n2>" Move 3,"T<n1>, @E T<n2>" Move 3,"J<n1>, J<n2>" Move 3,"J<n1>, @P J<n2>" Move 3,"J<n1>, @E J<n2>"

MOVE S,...	MOVE S, <i>n1</i> MOVE S, @P <i>n1</i> MOVE S, @E <i>n1</i>	Move 4, " <i>n1</i> " Move 4, "@P <i>n1</i> " Move 4, "@E <i>n1</i> "
Extended-joints	MOVE P, P< <i>n1</i> > EX((<i>j1</i> , <i>v1</i>)) MOVE P, P< <i>n1</i> > EX((<i>j1</i> , <i>v1</i>),(<i>j2</i> , <i>v2</i>)) MOVE P, P< <i>n1</i> > EXA((<i>j1</i> , <i>v1</i>)) MOVE P, P< <i>n1</i> > EXA((<i>j1</i> , <i>v1</i>),(<i>j2</i> , <i>v2</i>))	Move 1,"P< <i>n1</i> > EX((<i>j1</i> , <i>v1</i>)") Move 1,"P< <i>n1</i> > EX((<i>j1</i> , <i>v1</i>),(<i>j2</i> , <i>v2</i>))" Move 1,"P< <i>n1</i> > EXA((<i>j1</i> , <i>v1</i>)") Move 1,"P< <i>n1</i> > EXA((<i>j1</i> , <i>v1</i>),(<i>j2</i> , <i>v2</i>))"
Misc.	MOVE P, P< <i>n1</i> > +(x,y,z,rx,ry,rz) MOVE P, P< <i>n1</i> > +(x,y,z,rx,ry,rz)H	Move 1, DEV (" <i>n1</i> ", "P(x,y,z,rx,ry,rz)") Move 1, DEVH (" <i>n1</i> ", "P(x,y,z,rx,ry,rz)") <u>*Refer to CaoRobot::Execute for DEV and DEVH.</u>

<*n1*>, <*n2*> : Integers 0 to 65535 or "(<Element 1>, <Element 2>, ...)"

5.2.27. CaoRobot::Rotate method

Rotate the robot around the specified axis.

This method corresponds to ROTATE instruction of PacScript language.

This method is not available when a license key of b-CAP Slave is added and the robot is controlled by a client as a b-CAP SlaveMode.

The following shows the argument specifications of Rotate.

Syntax Rotate <vntRotSuf:POSEDATA>, <fDeg:FLOAT>, <vntPivot:POSEDATA>, <bstrOpt:BSTR>

vntRotSuf : [in] Rotation surface

fDeg : [in] Angle (deg)

vntPivot : [in] Rotation center

bstrOpt [in] Pass

[@0][@P][@E][@ <Value>]

Rotary option

[,Pose=*n*]

Pose=1: The posture changes along with rotation.

Pose=2: The posture at the current position (start point) is maintained and rotation motion is performed for the track only.

Motion option

[,SPEED=*n*][,ACCEL=*n*][,DECEL=*n*][,TIME=*n*][,NEXT]

SPEED (S): Specify the movement speed. The meaning is the same as the SPEED statement.

ACCEL: Specify the acceleration. The meaning is the same as the ACCEL statement.

DECEL: Specify the deceleration. The meaning is the same as the DECEL statement.

TIME: Specify the time to activate the motion.

NEXT: Asynchronous execution option.

Refer to "Appendix B. POSEDATA Type Definition" for the POSEDATA type. The form and the meaning when the character string is specified by the POSEDATA type are as follows.

In case of VT_BSTR type (string)

- vntRotSuf: [in] rotation surface
 "V<n1>,V<n2>,V<n3>" or "XY", "YZ", "ZX", "XYH", "YZH", "ZXH"
 or "V(<x>,<y>,<z>),V(...),V(...)"
 ex."V100,V101,V102"
 However, "XY", "YZ", "ZX", "XYH", "YZH", and "ZXH" are supported only by VT_BSTR.
- vntPivot: [in] rotation center
 "V<n4>" or "V(<x>,<y>,<z>)"
 ex."V103"

Example 1 Rotate"V1,V2,V3", 45.8,"V4","@E" ‘ ROTATE V1,V2,V3, @E 45.8, V4

Example 2 Rotate"V(0,0,1),V(0,1,0),V(0,0,0)", 30.0,"V(0,0,0)","@E,pose=1,NEXT"

Example 3 Rotate"XY", 90.0,"V(0,0,0)","@P"

Example 4 Rotate"XYH", -45.0,"V(250,0,0)","@150"

Rotation surface is determined by three points of V type variables in base coordinates. For arguments of vntRotSuf, specify three V type variables in BSTR (string) type variable separated by comma, space or tab.

Rotation center point vntPivot is specified by a V type variable expressed in BSTR(string) type.

5.2.28. CaoRobot::Speed method

Set the internal movement speed of the robot.

This method corresponds to SPEED and JSPEED instructions of PacScript language.

Actual speed is calculated by multiplying the external speed by the internal speed.

About the external movement speed of the robot, use "ExtSpeed" command of CaoRobot::Execute.

This method is not available when a license key of b-CAP Slave is added and the robot is controlled by a client as a b-CAP SlaveMode.

The following shows the argument specifications of Speed.

Syntax Speed <lAxis:LONG >, <fSpeed:FLOAT>

lAxis	:	[in]	Axis number	-1: Effective to Tool axis (SPEED), 0: Effective to all axes (JSPEED)
fSpeed	:	[in]	speed	

Example

```

Dim caoRob As CaoRobot
Set caoRob = caoCtrl.AddRobot("Arm0")

caoRob.Execute"TakeArm", Array(0, 0)

caoRob.Speed -1, 85           ' Internal speed of 85%
caoRob.Execute"ExtSpeed", 50 ' External speed 50%, Actual speed 85*50 = 42.5%

caoRob.Execute"GiveArm"

```

Internal speed can be changed temporarily per unit, by using SPEED option of the robot motion command, such as Move, Rotate, Drive and Draw. However, the internal speed will be reset to the value specified by CaoRobot::Speed after the motion completes. Normally, internal speed is initialized to 100% by TakeArm command of CaoRobot::Execute.

5.2.29. CaoRobot::Execute method

The "Execute method" defines peculiar operation commands to the robot that is not supported by the CaoRobot class, and offers the function to implement them.

Syntax [`<vntRet:VARIANT> =] Execute(<bstrCmd:BSTR > [,<vntParam:VARIANT>])`

```

bstrCmd      : [in]   Command
vntParam     : [in]   Parameter
vntRet       [out]   Return value

```

If a method not defined in this class is called using the runtime binding function, the Execute method is automatically called according to the following specifications.

```
vntRet = Obj.CommandName( Param1, Param2, ... )
```

↓

```
vntRet = Obj.Execute("CommandName", Array(Param1, Param2, ... ) )
```

1. The command name is passed as a BSTR string to the first argument.
2. All the parameters are passed as a VARIANT array to the second argument.

The list shows available commands.

Table 5-10 List of commands of CaoRobot::Execute method

Category	Command name	Function	Support Version	
Operation				
	TMul	Calculate the product of two homogeneous transformation type data.	1.0.0	P.102
	TInv	Calculate the inverse matrix of homogeneous transformation type data.	1.0.0	P.102
	TNorm	Calculate the inverse matrix of homogeneous transformation type data.	1.0.0	P.103
	J2T	Transform J type data to T type data.	1.0.0	P.103
	T2J	Transform T type data to J type data.	1.0.0	P.104
	J2P	Transform J type data to P type data.	1.0.0	P.104
	P2J	Transform P type data to J type data.	1.0.0	P.105
	T2P	Transform T type data to P type data.	1.0.0	P.105

P2T	Transform P type data to T type data.	1.0.0	P.106
Dev	Calculate the offset in the base coordinates.	1.0.0	P.106
DevH	Calculate the offset in the tool coordinates.	1.0.0	P.107
OutRange	Judge whether the motion range is exceeded.	1.0.0	P.107
MPS	Calculate the value of the SPEED command from data in Mps.	1.0.0	P.108
RPM	Calculate the value of the SPEED command from data in rpm.	1.0.0	P.108
DPS	Calculate the value of SPEED command from deg/s unit	1.7.2	P.109

Positioning

CurPos	Get the current position as P type data.	1.0.0	P.109
DestPos	Get the target position as P type data.	1.0.0	P.110
CurJnt	Get the current position as J type data.	1.0.0	P.112
DestJnt	Get the target position as J type data.	1.0.0	P.112
CurTrn	Get the current position as T type data.	1.0.0	P.114
DestTrn	Get the target position as T type data.	1.0.0	P.115
CurFig	Get the current posture Fig value.	1.0.0	P.117
CurPosEx	Get the current position data by P type data with time stamp.	1.4.9	P.110
DestPosEx	Get the target position data with time stamp as P type data.	1.4.9	P.111
HighCurPosEx	Get the current position data in real time with time stamp as P type data.	1.4.9	P.111
CurJntEx	Get the current position data by J type data with time stamp.	1.4.9	P.113
DestJntEx	Get the target position data with time stamp as J type data.	1.4.9	P.113
HighCurJntEx	Get the current position data in real time with time stamp as J type data.	1.4.9	P.114
CurTrnEx	Get the current position data by T type data with time stamp.	1.4.9	P.115
DestTrnEx	Get the target position data with time stamp as T type data.	1.4.9	P.116

HighCurTrnEx	Get the current position data in real time with time stamp as T type data.	1.4.9	P.116
Speed			
SpeedMode	Change the optimal speed setting function.	1.3.0	P.151
CurSpd	Return an internal speed setting value.	1.5.1	P.117
CurAcc	Return an internal acceleration setting value.	1.5.1	P.117
CurDec	Return an internal deceleration setting value.	1.5.1	P.118
CurJSpd	Return internal axis speed.	1.5.1	P.118
CurJAcc	Return internal axis acceleration.	1.5.1	P.118
CurJDec	Return internal axis deceleration.	1.5.1	P.119
Log			
StartLog	Start log recording.	1.0.0	P.120
StopLog	Stop log recording.	1.0.0	P.120
ClearLog	Clear log data.	1.0.0	P.121
StartServoLog	Start servo logging.	1.9.4	P.157
ClearServoLog	Delete obtained servo log data.	1.9.4	P.157
StopServoLog	Stop servo logging.	1.9.4	P.157
GetCtrlLogMaxTime	Get the duration of control logging.	1.0.0	P.157
SetCtrlLogMaxTime	Set the duration of control logging.	1.0.0	P.158
GetCtrlLogInterval	Get the interval of control logs.	1.0.0	P.158
SetCtrlLogInterval	Set the interval of control logs.	1.0.0	P.158
GetLogCount	Get count of control log.	1.0.0	P.165
GetLogRecord	Get data of control log.	1.0.0	P.165
Robot operation			
Motor	Turn ON/OFF the motor.	1.0.0	P.121
ExtSpeed	Set the external speed.	1.0.0	P.122
TakeArm	Request to get control authority.	1.0.0	P.122
GiveArm	Request to release control authority.	1.0.0	P.123
Draw	Execute the relative movement specified in the work coordinate system.	1.0.0	P.124
Approach	Execute the absolute movement specified in the tool coordinate system.	1.0.0	P.125

Depart	Execute the relative movement specified in the tool coordinate system.	1.0.0	P.126
DriveEx	Execute the relative motion of each axis.	1.0.0	P.127
DriveAEx	Execute the absolute motion of each axis.	1.0.0	P.128
RotateH	Execute rotary motion by taking an approach vector as an axis.	1.0.0	P.129
Arrive	Wait for the robot to reach the defined motion ratio.	1.0.0	P.129
MotionSkip	Abort the robot motion in progress.	1.0.0	P.130
MotionComplete	Judge whether the robot motion is complete.	1.0.0	P.130
ArchMove	Perform an arch motion.	1.4.2	P.140
Tool			
CurTool	Get the current tool number.	1.0.0	P.131
GetToolDef	Get the tool definition specified by the tool number.	1.0.0	P.131
SetToolDef	Set the tool definition.	1.0.0	P.132
Work			
CurWork	Get the current work number.	1.0.0	P.132
GetWorkDef	Get the work definition specified by the work number.	1.0.0	P.132
SetWorkDef	Set the work definition.	1.0.0	P.133
WorkAttribute	Get work attribute specified by a work number.	1.7.11	P.133
Base			
SetBaseDef	Specify the base definition.	1.7.16	P.155
GetBaseDef	Obtain the base definition.	1.7.16	P.156
Area			
GetAreaDef	Get the area definition specified by the area number.	1.0.0	P.134
SetAreaDef	Set the area parameter.	1.0.0	P.134
SetArea	Enable the area check.	1.0.0	P.135
ResetArea	Disable the area check.	1.0.0	P.135
AreaSize	Return the size (each side length) of a check area as the vector type.	1.0.0	P.136
GetAreaEnabled	Get the area enabled or disabled status.	1.0.0	P.136

	SetAreaEnabled	Set the area enabled or disabled status.	1.0.0	P.136
Spline				
	AddPathPoint	Add a path point to the path data.	1.3.1	P.137
	ClrPathPoint	Clear the whole path points.	1.3.1	P.137
	GetPathPoint	Get a path point to the path data.	1.3.1	P.138
	LoadPathPoint	Load a path data.	1.3.1	P.138
	GetPathPointCount	Get the number of path points.	1.3.1	P.139
Force Control				
	ForceCtrl	Enable/Disable the force control function.	1.3.1	P.142
	ForceParam	Set parameters for force control function.	1.4.2	P.143
	ForceValue	Get values of force control specified by arguments.	1.5.1	P.144
	ForceWaitCondition	Wait until the condition specified by the force control is satisfied.	1.6.0	P.145
	ForceSensor	Control the force sensor.	1.5.1	P.146
	ForceChangeTable	Change the force control table which is currently controlled.	1.6.3	P.146
	CurForceParam	Obtain current parameters for force control function (compliance function).	2.0.10	P.164
Cooperative Control Function				
	SyncTimeStart	Declare that multiple robots start and stop their motion simultaneously.	1.7.13	P.153
	SyncTimeEnd	Start the synchronous motion with multiple robots.	1.7.13	P.154
	SyncMoveStart	Declare that multiple robots will work together to complete a task.	1.7.13	P.154
	SyncMoveEnd	Start the cooperative motion with multiple robots.	1.7.13	P.155
	SetHandIO	Set I/O number, values, and range of Hand I/O.	1.8.10	P.156
	GetHandIO	Obtain IO number, range, and values of HandI/O.	1.8.10	P.156

Exclusive Control of Robots				
	ExclusiveArea	Create or change an exclusive area.	1.11.1	P.161
	SetExclusiveArea	Enable the exclusive area.	1.11.1	P.162
	ResetExclusiveArea	Disable the exclusive area.	1.11.1	P.162
	ExclusiveControlStatus	Obtain the exclusive control status.	1.11.1	P.162
Accuracy				
	CrtMotionAllow	Change the stop precision settings.(@C)	1.3.3	P.140
	EncMotionAllow	Change the "Allowable angle in stop state" of robot axis.(@E)	1.3.3	P.141
	EncMotionAllowJnt	Change the "Allowable angle in stop state" of other than robots' axis.(@E)	1.4.2	P.141
	HighPathAccuracy	Switch "True/False" of the high tracing control function.	1.3.7	P.150
Status/Value Obtainment				
	GetSrvData	Get servo internal data of the robot axis.	1.0.0	P.147
	GetSrvJntData	Get servo internal data of the other than robots' axis.	1.0.0	P.147
	GetAllSrvData	Obtain servo internal data at one time.	2.3.0	P.163
	RobInfo	Return the robot information.	1.7.11	P.153
Settings of Functions and Conditions				
	GrvCtrl	Switch "True/False" of Gravity Compensation Control Function.	1.0.0	P.148
	GrvOffset	Configure "True/False" of dead weight correction function.	1.0.0	P.149
	MotionTimeout	Change a timeout setting value of the motion instruction.	1.4.2	P.150
	ErAlw	Configure the deviation tolerance function.	1.0.0	P.142
	PayLoad	Change the setting value of internal load conditions.	1.0.0	P.152

	SingularAvoid	Enable or disable singularity avoidance function.	1.3.1	P.151
Current Limit				
	CurLmt	Configure the current limiting function.	1.0.0	P.148
	Zforce	Specify the thrust force for current limiting function.	1.4.2	P.149
Coordination with Position, Motion and I/O				
	DetectOn	Enable Detect function.	1.3.0	P.159
	DetectOff	Disable the Detect function and then store the data.	1.3.0	P.159
	AngularTrigger	Switch ON/OFF the specified IO whenever a robot moves by a specified angle or distance.	1.4.1	P.160
Virtual Fence				
	VirtualFence	Start or stop monitoring the virtual fence.	1.12.0	P.161
Misc.				
	GetRobotTypeName	Get the robot type.L.	1.0.0	P.139
	GetPluralServoData	Obtain multiple servo data at one time.	1.10.1	P.160
	GenerateNonStopPath	This command is exclusive to "the Non-stop motion calculator option."	1.6.2	P.152

The arguments of the Execute method of the CaoRobot class specify a command number + parameter as a VARIANT array.

Example

```

-----
Dim vRes as Variant
vRes = caoRob.Execute("GetJntData",Array(1, 6)) ' Current motor speed of 6 axes [rpm]
caoRob.Execute("ExtSpeed",Array(50.0, 25.0, 25.0)
               ' External speed = 50%, acceleration = 25%, deceleration = 25%
caoRob.Execute"APPROACH", Array(1,"P11","@P 100","NEXT") 'APPROACH P,P11,@P 100, NEXT
-----

```

5.2.29.1. CaoRobot::Execute("TMul") command

Calculate the product of two homogeneous transformation type data.

Syntax TMul (<Tn1>, <Tn2>)

<Tn1>	:	[in] T type (POSEDATA)
<Tn2>	:	[in] T type (POSEDATA)
Return value	:	Product of <Tn1> and <Tn2> (VT_VARIANT[VT_R8 VT_ARRAY:10 element])

Example

```

Dim vResult As Variant

vResult = caoRob.Execute("TMul", Array("T10","T20" ) ) ' Calculate by specifying the T type index

vResult = caoRob.Execute("TMul", Array("T(400,500,400, 1,0,0, 0,1,0, 5)", _
"(T( 100,0,0, 1,0,0, 0,1,0, -1)" ) ) ' Calculate by specifying the T type element directly

```

5.2.29.2. CaoRobot::Execute("TInv") command

Calculate the inverse matrix of T (homogeneous transformation) type data.

Syntax TInv(<Tn1>)

<Tn1>	:	[in] T type (POSEDATA)
Return value	:	Inverse matrix of <Tn1> (VT_VARIANT[VT_R8 VT_ARRAY:10 element])

Example

```

Dim vResult As Variant
vResult = caoRob.Execute("TInv", "T10" ) ' Inverse matrix of T10
vResult = caoRob.Execute("TInv", "T(400,500,400, 1,0,0, 0,1,0, 5)" )
' Calculate by specifying the T type element directly

```

5.2.29.3. CaoRobot::Execute("TNorm") command

Normalize T (homogeneous transformation) type data.

Syntax TNorm(<Tn1>)

<Tn1> : [in] T type (POSEDATA)
 Return value : Normalization of <Tn1>
 (VT_VARIANT[VT_R8|VT_ARRAY:10 element])

Example

```
-----
Dim vResult As Variant

vResult = caoRob.Execute("TNorm", "T10" ) ' Normalization of T10

vResult = caoRob.Execute("TNorm", "T(400,500,400, 1,0,0, 0,1,0, 5)" )
' Calculate by specifying the T type element directly
-----
```

5.2.29.4. CaoRobot::Execute("J2T") command

Transform J type data to T type data.

Syntax J2T (<Jn1>)

<Jn1> : [in] J type (POSEDATA)
 Return value : T type
 (VT_VARIANT[VT_R8|VT_ARRAY:10 element])

Example

```
-----
Dim vResult As Variant

vResult = caoRob.Execute("J2T", "J10" ) ' Transform J10 value to T type data

vResult = caoRob.Execute("J2T", "J(90,90,90, 0,0,0)" )
' Transform by specifying the J type element directly
-----
```

5.2.29.5. CaoRobot::Execute("T2J") command

Transform T type data to J type data.

Syntax T2J (<Tn1>)

<Tn1> : [in] T type (POSEDATA)
 Return value : J type
 (VT_VARIANT[VT_R8|VT_ARRAY:8 element])

Example

```
-----
Dim vResult As Variant

vResult = caoRob.Execute("T2J", "T10" ) ' Transform T10 value to J type data

vResult = caoRob.Execute("T2J", "T(400,400,500, 1,0,0, 0,1,0, 5)" )
' Transform by specifying the T type element directly
-----
```

5.2.29.6. CaoRobot::Execute("J2P") command

Transform J type data to P type data.

Syntax J2P (<Jn1>)

<Jn1> : [in] J type (POSEDATA)
 Return value : P type
 (VT_VARIANT[VT_R8|VT_ARRAY:7 element])

Example

```
-----
Dim vResult As Variant

vResult = caoRob.Execute("J2P", "J10" ) ' Transform J10 value to P type data

vResult = caoRob.Execute("J2P", "J(90,90,90, 0,0,0)" )
' Transform by specifying the J type element directly
-----
```

5.2.29.7. CaoRobot::Execute("P2J") command

Transform P type data to J type data.

Syntax P2J (<Pn1>)

<Pn1> : [in] P type (POSEDATA)
 Return value : J type
 (VT_VARIANT[VT_R8|VT_ARRAY:8 element])

Example

```
-----
Dim vResult As Variant

vResult = caoRob.Execute("P2J", "P10" ) ' Transform P10 value to J type data

vResult = caoRob.Execute("P2J", "P(400,400,500, 180,0,180, 5)" )
' Transform by specifying the P type element directly
-----
```

5.2.29.8. CaoRobot::Execute("T2P") command

Transform T type data to P type data.

Syntax T2P (<Tn1>)

<Tn1> : [in] T type (POSEDATA)
 Return value : P type
 (VT_VARIANT[VT_R8|VT_ARRAY:7 element])

Example

```
-----
Dim vResult As Variant

vResult = caoRob.Execute("T2P", "T10" ) ' Transform T10 value to P type data

vResult = caoRob.Execute("T2P", "T(400,400,500, 1,0,0, 0,1,0, 5)" )
' Transform by specifying the T type element directly
-----
```

5.2.29.9. CaoRobot::Execute("P2T") command

Transform P type data to T type data.

Syntax P2T (<Pn1>)

<Pn1> : [in] P type (POSEDATA)
 Return value : T type
 (VT_VARIANT[VT_R8|VT_ARRAY:10 element])

Example

```
-----
Dim vResult As Variant

vResult = caoRob.Execute("P2T", "P10" ) ' Transform P10 value to T type data

vResult = caoRob.Execute("P2T", "P(400,400,500, 180,0,180, 5)" )
' Transform by specifying the P type element directly
-----
```

5.2.29.10. CaoRobot::Execute("Dev") command

Calculate the coordinates of the offset <Pn2> from the reference position <Pn1> in the base coordinates.

The Fig value of the offset <Pn2> is ignored.

Syntax Dev (<Pn1>, <Pn2>)

<Pn1> : [in] P type (POSEDATA)
 <Pn2> : [in] P type (POSEDATA)
 Return value : P type
 (VT_VARIANT[VT_R8|VT_ARRAY:7 element])

Example

```
-----
Dim vResult As Variant

vResult = caoRob.Execute("Dev", Array("P10","P(100, 200, 300, 180, 0, 180)" ))
' Calculate the positions of P10 + P(100, 200, 300, 180, 0, 180)
-----
```

5.2.29.11. CaoRobot::Execute("DevH") command

Calculate the coordinates of the offset <Pn2> from the reference position <Pn1> in the tool coordinates. The Fig value of the offset <Pn2> is ignored.

Syntax DevH (<Pn1>, <Pn2>)

<Pn1>	:	[in] P type (POSEDATA)
<Pn2>	:	[in] P type (POSEDATA)
Return value	:	P type (VT_VARIANT[VT_R8 VT_ARRAY:7 element])

Calculation is performed based on the coordinates of the currently effective tool definition (current tool).

Example

Dim vResult As Variant

vResult = caoRob.Execute("DevH", Array("P10", "P(100, 200, 300, 180, 0, 180)"))
' Calculate the positions of P10 + Tool coordinate P (100, 200, 300, 180, 0, 180)

5.2.29.12. CaoRobot::Execute("OutOfRange") command

Return a result whether the position data is within the robot's motion range.

The tool and work definition are ignored if <Pose> is specified as J type data. The tool and work definition specified as POSEDATA (P type) is available since Controller version 2.0.*.

Syntax OutRange(<Pose>[, <ToolDef> [, <WorkDef>]])

<Pose>	:	[in] POSEDATA value (one of P, J, and T types)
<ToolDef>	:	[in] Tool definition. POSEDATA (P type) or VT_I4 POSEDATA (P type) : Tool definition. VT_I4 : Tool number.-1 (default) is the current tool number VT_I4.
<WorkDef>	:	[in] Work definition. POSEDATA (P type) or VT_I4 POSEDATA (P type) : Work definition. VT_I4 : Work number.-1 (default) is the current work number VT_I4.
Return value	:	VT_I4 0: Within motion range 1 to 63: Bit of axis that is software limit -1: Impossible position due to axis configuration -2: Singular point

Example Move if the motion range is not exceeded.

Dim IRet As Long

```
IRet = caoRob.Execute("OutOfRange", "P(400, 400, 300, 180, 0, 180, 5)" )
```

5.2.29.13. CaoRobot::Execute("MPS") command

Transform an operation speed in mm/sec to a SPEED command value in %.

Syntax Mps(<mps>)

<mps> : [in] Speed value in mm/sec (VT_R4)
 Return value : SPEED command value in % (VT_R4)

Example Transform an absolute speed to a relative speed.

```
Dim vSp As Variant
```

```
vSp = caoRob.Execute("MPS", 200.0) ' 200.0 mm/sec  
caoRob.Speed -1, vSP
```

5.2.29.14. CaoRobot::Execute("RPM") command

Transform a rotation speed in rpm to a SPEED command value in %.

Syntax Rpm(<Axis>, <rpm>)

<Axis> : [in] Axis number (VT_I4)
 <rpm> : [in] Rotation speed in rpm (VT_R4)
 Return value : SPEED command value in % (VT_R4)

Example Transform a rotation speed in RPM to a relative speed in %.

```
Dim vSp As Variant
```

```
vSp = g_caoRobot.Execute("RPM", Array(1, 60)) ' Axis 1, 60.0 rpm  
caoRob.Speed -1, vSP
```

5.2.29.15. CaoRobot::Execute("DPS") command

Convert the rotation speed (deg/s) of the specified axis to the ratio against the maximum internal speed at PTP motion. If the axis number is not specified, convert the rotation speed (deg/s) to the ratio against the maximum internal speed at CP motion.

Syntax DPS(<Axis>, <deg/s>)

<Axis> : [in] Axis number (VT_I4)
 <deg/s> : [in] Value of rotation speed by "deg/s" (VT_R4)
 Return value : Value of SPEED command by "%" (VT_R4)

Example Conversion from the rotation speed (deg/s) to the relative speed (%)

```
-----
Dim vSp As Variant
' Move by 50(Deg/sec) (when in rotation)
vSp = g_caoRobot.Execute("DPS", 50)
caoRob.Speed -1,vSp

' Move the first axis by 50(deg/sec)
vSp = g_caoRobot.Execute("DPS", Array(1, 50))
caoRob.Speed 0,vSp
-----
```

5.2.29.16. CaoRobot::Execute("CurPos") command

Get the current position, which is updated in every 8 milliseconds in the controller, by P type data.

Syntax CurPos()

Argument : None
 Return value : P type (VT_VARIANT[VT_R8|VT_ARRAY:7 element])

This is equivalent to a value that can be acquired in the system variable "@Current_Position".

Example

```
-----
Dim vResult As Variant

vResult = caoRob.Execute("CurPos") ' Get current position
-----
```

5.2.29.17. CaoRobot::Execute("DestPos") command

Get the target position as P type data.

Syntax DestPos()

Argument : None
Return value : P type (VT_VARIANT[VT_R8|VT_ARRAY:7 element])

This is equivalent to a value that can be acquired in the system variable "@Dest_Position".

Example

```
-----
Dim vResult As Variant
vResult = caoRob.Execute("DestPos") ' Get target position
-----
```

5.2.29.18. CaoRobot::Execute ("CurPosEx") command

Get the current position data, which is updated in every 8 milliseconds in the controller, by P type data with time stamp.

Time stamp: Elapsed time from turning the controller power supply on (msec)

Syntax CurPosEx()

Argument : None
Return value : Time stamp + P type
(VT_VARIANT[VT_R8|VT_ARRAY:1+7 elements])
{Time, X, Y, ...}

Example

```
-----
Dim vResult As Variant
vResult = caoRob.Execute("CurPosEx") 'Time stamp+ Get current position
-----
```

5.2.29.19. CaoRobot::Execute("DestPosEx") command

Get the target position data with time stamp as P type data.

Time stamp: Elapsed time from turning the controller power supply on (msec)

Syntax DestPosEx()

Argument	:	None
Return value	:	Time stamp + P type (VT_VARIANT[VT_R8 VT_ARRAY:1+7 elements]) {Time, X, Y, ...}

Example

Dim vResult As Variant

vResult = caoRob.Execute("DestPosEx") 'Time stamp+ Get target position

5.2.29.20. CaoRobot::Execute("HighCurPosEx") command

Get the current position data in real time with time stamp as P type data.

Encoder value is returned if the robot is not machine-locked.

This command might cause a high load on the controller.

Time stamp: Elapsed time from turning the controller power supply on (msec)

Syntax HighCurPosEx()

Argument	:	None
Return value	:	Time stamp + P type (VT_VARIANT[VT_R8 VT_ARRAY:1+7 elements]) {Time, X, Y, ...}

Example

Dim vResult As Variant

vResult = caoRob.Execute("HighCurPosEx") 'Time stamp+ Get current position

5.2.29.21. CaoRobot::Execute("CurJnt") command

Get the current position data, which is updated in every 8 milliseconds in the controller, by J type data.

Syntax CurJnt()

Argument : None
Return value : J type (VT_VARIANT[VT_R8|VT_ARRAY:8 element])

This is equivalent to a value that can be acquired in the system variable "@Current_Angle".

Example

```
-----  
Dim vResult As Variant  
vResult = caoRob.Execute("CurJnt") ' Get current position  
-----
```

5.2.29.22. CaoRobot::Execute("DestJnt") command

Get the target position as J type data.

Syntax DestPos()

Argument : None
Return value : P type (VT_VARIANT[VT_R8|VT_ARRAY:8 element])

This is equivalent to a value that can be acquired in the system variable "@Dest_Angle".

Example

```
-----  
Dim vResult As Variant  
vResult = caoRob.Execute("DestJnt") ' Get target position  
-----
```

5.2.29.23. CaoRobot::Execute("CurJntEx") command

Get the current position data, which is updated in every 8milliseconds in the controller, by J type data with time stamp.

Time stamp: Elapsed time from turning the controller power supply on (msec)

Syntax CurJntEx()

Argument	:	None
Return value	:	Time stamp+J type (VT_VARIANT[VT_R8 VT_ARRAY:1+8 elements]) {Time, J1, J2, ...}

Example

```
-----  
Dim vResult As Variant  
vResult = caoRob.Execute("CurJntEx" ) 'Time stamp+Get current position  
-----
```

5.2.29.24. CaoRobot::Execute("DestJntEx") command

Get the target position data with time stamp as J type data.

Time stamp: Elapsed time from turning the controller power supply on (msec)

Syntax DestJntEx()

Argument	:	None
Return value	:	Time stamp+J type (VT_VARIANT[VT_R8 VT_ARRAY:1+8 elements]) {Time, J1, J2, ...}

Example

```
-----  
Dim vResult As Variant  
vResult = caoRob.Execute("DestJntEx" ) 'Time stamp+Get target position  
-----
```

5.2.29.25. CaoRobot::Execute("HighCurJntEx") command

Get the current position data in real time with time stamp as J type data.

Encoder value is returned if the robot is not machine-locked.

This command might cause a high load on the controller.

Time stamp: Elapsed time from turning the controller power supply on (msec)

Syntax HighCurJntEx()

Argument	:	None
Return value	:	Time stamp+J type (VT_VARIANT[VT_R8 VT_ARRAY:1+8 elements]) {Time, J1, J2, ...}

Example

```
-----
Dim vResult As Variant
vResult = caoRob.Execute("HighCurJntEx" ) 'Time stamp+Get current position
-----
```

5.2.29.26. CaoRobot::Execute("CurTrn") command

Get the current position data, which is updated in every 8milliseconds in the controller, by T type data.

Syntax CurTrn()

Argument	:	None
Return value	:	T type (VT_VARIANT[VT_R8 VT_ARRAY:10 element])

This is equivalent to a value that can be acquired in the system variable "@Current_Trans".

Example

```
-----
Dim vResult As Variant
vResult = caoRob.Execute("CurTrn" ) ' Get current position
-----
```

5.2.29.27. CaoRobot::Execute("DestTrn") command

Get the target position as T type data.

Syntax DestTrn()

Argument : None
Return value : T type (VT_VARIANT[VT_R8|VT_ARRAY:10 element])

This is equivalent to a value that can be acquired in the system variable "@Dest_Trans".

Example

```
-----
Dim vResult As Variant
vResult = caoRob.Execute("DestTrn" ) ' Get target position
-----
```

5.2.29.28. CaoRobot::Execute("CurTrnEx") command

Get the current position data, which is updated in every 8milliseconds in the controller, by T type data with time stamp.

Time stamp: Elapsed time from turning the controller power supply on (msec)

Syntax CurTrnEx()

Argument : None
Return value : Time stamp+T type
(VT_VARIANT[VT_R8|VT_ARRAY:1+10 elements])
{Time, X, Y, ...}

Example

```
-----
Dim vResult As Variant
vResult = caoRob.Execute("CurTrnEx" ) 'Time stamp+Get current position
-----
```

5.2.29.29. CaoRobot::Execute("DestTrnEx") command

Get the target position data with time stamp as T type data.

Time stamp: Elapsed time from turning the controller power supply on (msec)

Syntax DestTrnEx()

Argument	:	None
Return value	:	Time stamp + T type (VT_VARIANT[VT_R8 VT_ARRAY:1+10 elements]) {Time, X, Y, ...}

Example

```
-----
Dim vResult As Variant
vResult = caoRob.Execute("DestTrnEx" ) 'Time stamp+Get target position
-----
```

5.2.29.30. CaoRobot::Execute("HighCurTrnEx") command

Get the current position data in real time with time stamp as T type data.

Encoder value is returned if the robot is not machine-locked.

This command might cause a high load on the controller.

Time stamp: Elapsed time from turning the controller power supply on (msec)

Syntax HighCurTrnEx()

Argument	:	None
Return value	:	Time stamp + T TYPE (VT_VARIANT[VT_R8 VT_ARRAY:1+10 elements]) {Time, X, Y, ...}

Example

```
-----
Dim vResult As Variant
vResult = caoRob.Execute("HighCurTrnEx" ) 'Time stamp+Get current position
-----
```

5.2.29.31. CaoRobot::Execute("CurFig") command

Get the Fig value that indicates the current posture.

Syntax CurFig()

Argument : None
Return value : Fig value (VT_14)

Example

```
-----  
Dim vFig As Variant  
vFig = caoRob.Execute("CurFig") ' Get current Fig  
-----
```

5.2.29.32. CaoRobot::Execute("CurSpd") command

Return an internal speed setting value.

Syntax CurSpd([arm group])

Argument : Arm group(VT_I4)
Return value : Internal speed (VT_R4)

Example

```
-----  
Dim vSpd As Variant  
vSpd = caoRob.Execute("CurSpd",0)  
-----
```

5.2.29.33. CaoRobot::Execute("CurAcc") command

Return an internal acceleration setting value.

Syntax CurAcc([arm group])

Argument : Arm group(VT_I4)
Return value : Internal acceleration (VT_R4)

Example

```
-----  
Dim vSpd As Variant  
vSpd = caoRob.Execute("CurAcc",0)  
-----
```

5.2.29.34. CaoRobot::Execute("CurDec") command

Return an internal deceleration setting value.

Syntax CurDec([arm group])

Argument : Arm group(VT_I4)
Return value : Internal deceleration (VT_R4)

Example

```
-----  
Dim vSpd As Variant  
vSpd = caoRob.Execute("CurDec" ,0)  
-----
```

5.2.29.35. CaoRobot::Execute("CurJSpd") command

Return internal axis speed.

Syntax CurJSpd([arm group])

Argument : Arm group(VT_I4)
Return value : Internal axis speed (VT_R4)

Example

```
-----  
Dim vSpd As Variant  
vSpd = caoRob.Execute("CurJSpd" ,0)  
-----
```

5.2.29.36. CaoRobot::Execute("CurJAcc") command

Return internal axis acceleration.

Syntax CurJAcc([arm group])

Argument : Arm group(VT_I4)
Return value : Internal axis acceleration (VT_R4)

Example

```
-----  
Dim vSpd As Variant  
vSpd = caoRob.Execute("CurJAcc" ,0)  
-----
```

5.2.29.37. CaoRobot::Execute("CurJDec") command

Return internal axis deceleration.

Syntax CurJDec([arm group])

Argument : Arm group(VT_I4)
Return value : Internal axis deceleration (VT_R4)

Example

```
-----  
Dim vSpd As Variant  
vSpd = caoRob.Execute("CurJDec" ,0)  
-----
```

5.2.29.38. CaoRobot::Execute("CurExtSpd") command

Return an external speed setting value.

Syntax CurExtSpd()

Argument : None
Return value : External speed (VT_R4)

Example

```
-----  
Dim vSpd As Variant  
vSpd = caoRob.Execute("CurExtSpd" )  
-----
```

5.2.29.39. CaoRobot::Execute("CurExtAcc") command

Return an external acceleration setting value.

Syntax CurExtAcc()

Argument : None
Return value : External acceleration (VT_R4)

Example

```
-----  
Dim vAcc As Variant  
vAcc = caoRob.Execute("CurExtAcc")  
-----
```

5.2.29.40. CaoRobot::Execute("CurExtDec") command

Return an external deceleration setting value.

Syntax CurExtDec()

Argument	:	None
Return value	:	External deceleration (VT_R4)

Example

```
-----  
Dim vDec As Variant  
vDec = caoRob.Execute("CurExtDec")  
-----
```

5.2.29.41. CaoRobot::Execute("StartLog") command

Stop recording logs when the allowable number of logs for sampling is reached since the execution of StartLog after control log recording is started by ClearLog.

This method is not available when a license key of b-CAP Slave is added and the robot is controlled by a client as a b-CAP SlaveMode.

Syntax StartLog()

Argument	:	None
Return value	:	None

Execute the ClearLog command before this command to enable recording.

Example

```
-----  
caoRob.Execute"StartLog"  
-----
```

5.2.29.42. CaoRobot::Execute("StopLog") command

The execution of StopLog stops recording control logs after control log recording is started by ClearLog.

Syntax StopLog()

Argument	:	None
Return value	:	None

Execute the ClearLog command before this command to enable recording.

Example

```
-----  
caoRob.Execute"StopLog"  
-----
```

5.2.29.43. CaoRobot::Execute("ClearLog") command

Start control log recording.

Syntax ClearLog()

Argument : None

Return value : None

Clear the control log data and start sampling to the ring buffer.

This method is not available in SlaveMode.

Example

```
-----  
caoRob.Execute"ClearLog"  
-----
```

5.2.29.44. CaoRobot::Execute("Motor") command

Turn ON/OFF the motor.

This method is not available when a license key of b-CAP Slave is added and the robot is controlled by a client as a b-CAP SlaveMode.

Syntax Motor (<State> [,<NoWait>])

State : [in] Motor status (VT_I4)

0: Motor OFF

1: Motor ON

NoWait : [in] Completion wait (VT_I4)

0:Wait for completion (default)

1: Do not wait for completion

Return value : None

Example

```
-----  
caoRob.Execute"Motor",Array(1,0) Turn on motor and wait for completion of motor ON process  
-----
```

5.2.29.45. CaoRobot::Execute("ExtSpeed") command

Set the external speed, external acceleration, and external deceleration.

This method is not available when a license key of b-CAP Slave is added and the robot is controlled by a client as a b-CAP SlaveMode.

Syntax ExtSpeed (<Speed> [,<Accel> [,<Decel>]])

Speed	:	[in] External speed (VT_R4)
Accel	:	[in] External acceleration (VT_R4) -1 (default): Keep the current setting (Not change the current setting) "-2" is entered if it is omitted.
Decel	:	[in] External deceleration (VT_R4) -1 (default): Keep the current setting (Not change the current setting) "-2" is entered if it is omitted.
Return value	:	None

Example

```
-----
caoRob.Execute"ExtSpeed", Array(50.0, 25.0, 25.0 )
                                     ' External speed = 50%, acceleration = 25%, deceleration = 25%

caoRob.Execute"ExtSpeed", Array(50.0) ' External speed=50% (Acceleration, deceleration are set
automatically)
-----
```

Actual speed is calculated by multiplying the external speed by the internal speed. Internal speed is specified by Speed command.

5.2.29.46. CaoRobot::Execute("TakeArm") command

Request to get control authority.

This command corresponds to TAKEARM instruction of PacScript language.

This method is not available when a license key of b-CAP Slave is added and the robot is controlled by a client as a b-CAP SlaveMode.

Syntax TakeArm ([<ArmGroup> , [<Keep>]])

ArmGroup	:	[in] Arm group number (VT_I4) 0 to 31 (0 by default) (0 is an Armgroup that includes robot joints only and does not include any Extended-joints)
Keep	:	[in] Default value (VT_I4) 0: Set the internal speed to 100, the current tool number to 0, and the current work number to 0.

1: Keep the current internal speed, the current tool number and the current work number without change.

(0 by default)

※If Keep option is not specified, the internal speed, the current tool number and the current work number are initialized to 100, 0 and 0, respectively.

Return value : None

Example

 caoRob.Execute"Takearm",Array(0,0) 'Intialize the internal speed to 100, the current tool to 0, and the current wor to 0.
 :

'When the internal speed is 50, the current tool is 1, and the current work is 0
 caoRob.Execute"Takearm",Array(0,1) 'Not initialize the internal speed, current tool and current work,
 'and then get the control authority only.

5.2.29.47. CaoRobot::Execute("GiveArm") command

Request to release control authority.

This command corresponds to GIVEARM instruction of PacScript language.

Syntax GiveArm ()

Argument : None

Return value : None

Example

 ' When a program that has executed Takearm is terminated,
 ' the robot halts before Givearm is executed.
 ' To terminate the program after completion of Next motion,
 ' explicitly execute Givearm command.

caoRob.Execute"Takearm",Array(0,0)
 caoRob.Move 1,"@0 J(0,45,90,0,45,0)"
 caoRob.Move 1,"@0 J(90,45,90,0,45,0)","Next"
 Set IO[129]
 Set IO[130]
 caoRob.Execute"GiveArm" ' Wait until Next motion completes.'

5.2.29.48. CaoRobot::Execute("Draw") command

Execute the relative movement specified in the work coordinate system

This command corresponds to DRAW instruction of PacScript language.

This method is not available when a license key of b-CAP Slave is added and the robot is controlled by a client as a b-CAP SlaveMode.

Syntax Draw (<lComp>,<vntPose>[,<strOpt>])

lComp	:	[in] Interpolation method (VT_I4) 1: PTP motion 2: CP motion
vntPose	:	[in] Distance (POSEDATA type, C1 format) " [<@pass start displacement>] <Parallel movement distance> "
strOpt	:	[in] Motion option (VT_BSTR) [SPEED=n][,ACCEL=n][,DECEL=n][,TIME=n][,NEXT] SPEED (S): Specify the movement speed. The meaning is the same as the SPEED statement. ACCEL: Specify the acceleration. The meaning is the same as the ACCEL statement. DECEL: Specify the deceleration. The meaning is the same as the DECEL statement. TIME: Specify the time to activate the motion. NEXT: Asynchronous execution option.
Return value	:	None

Example

```
caoRob.Execute"Draw", Array(1,"V0")
caoRob.Execute"Draw", Array(2,"V(100, 100, 100)")
```

5.2.29.49. CaoRobot::Execute("Approach") command

Move to the approach position that is as far to the reference position as the specified distance.

This command corresponds to APPROACH instruction of PacScript language.

This method is not available when a license key of b-CAP Slave is added and the robot is controlled by a client as a b-CAP SlaveMode.

Syntax Approach (<lComp>,<vntPoseBase>,<vntPoseLen>[,<strOpt>])

lComp	:	[in] Interpolation method (VT_I4) 1: PTP motion 2: CP motion
vntPoseBase	:	[in] Reference position (POSEDATA type, C0 format) "<Position: P, T, or J type>" An error occurs if the pass start displacement is specified in POSEDATA type C0 format.
vntPoseLen	:	[in] Approach length (POSEDATA type, C2 format) "[Pass start displacement]<Value (mm)>"
strOpt	:	[in] Motion option (VT_BSTR) [SPEED=n][,ACCEL=n][,DECEL=n][,TIME=n][,NEXT] SPEED (S): Specify the movement speed. The meaning is the same as the SPEED statement. ACCEL: Specify the acceleration. The meaning is the same as the ACCEL statement. DECEL: Specify the deceleration. The meaning is the same as the DECEL statement. TIME: Specify the time to activate the motion. NEXT: Asynchronous execution option.
Return value	:	None

Example

```
caoRob.Execute"Approach",Array(1," P1","@P 100","S=50")
caoRob.Execute"Approach",Array(2," P(400, 200, 350, 180, 0, 180, 5)","@E 56.8","S=30, NEXT")
```

5.2.29.50. CaoRobot::Execute("Depart") command

Move from the current position along the Z axis in the tool coordinates.

This command corresponds to DEPART instruction of PacScript language.

This method is not available when a license key of b-CAP Slave is added and the robot is controlled by a client as a b-CAP SlaveMode.

Syntax Depart (<lComp>,<vntPoseLen>[,<strOpt>])

lComp	:	[in] Interpolation method (VT_I4) 1: PTP motion 2: CP motion
vntPoseLen	:	[in] Depart length (POSEDATA type, C2 format) "[Pass start displacement]<Value (mm)>"
strOpt	:	[in] Motion option (VT_BSTR) [SPEED=n][,ACCEL=n][,DECEL=n][,TIME=n][,NEXT] SPEED (S): Specify the movement speed. The meaning is the same as the SPEED statement. ACCEL: Specify the acceleration. The meaning is the same as the ACCEL statement. DECEL: Specify the deceleration. The meaning is the same as the DECEL statement. TIME: Specify the time to activate the motion. NEXT: Asynchronous execution option.
Return value	:	None

Example

```
-----
caoRob.Execute"Depart",Array(1,"@P 100","S=50")
caoRob.Execute"Depart",Array(2"@E 56.8","S=30, NEXT")
-----
```

5.2.29.51. CaoRobot::Execute("DriveEx") command

Execute the relative motion of each axis.

This command corresponds to DRIVE instruction of PacScript language.

This method is not available when a license key of b-CAP Slave is added and the robot is controlled by a client as a b-CAP SlaveMode.

Syntax DriveEx (<vntPoses> [, < strOpt >])

vntPoses	:	[in] Axis number and distance (POSEDATA type, C3 format) Specify the desired axes and distances in POSEDATA type for eight axes at the maximum.
strOpt	:	[in] Motion option (VT_BSTR) [SPEED=n][,ACCEL=n][,DECEL=n][,TIME=n][,NEXT] SPEED (S): Specify the movement speed. The meaning is the same as the SPEED statement. ACCEL: Specify the acceleration. The meaning is the same as the ACCEL statement. DECEL: Specify the deceleration. The meaning is the same as the DECEL statement. TIME: Specify the time to activate the motion. NEXT: Asynchronous execution option.
Return value	:	None

Example

```
-----
vntPoses = "@0 (1, 10), (2, 10)"
caoRob.Execute "DriveEX", Array(vntPoses, "S=10, NEXT")
-----
```

5.2.29.52. CaoRobot::Execute("DriveAEx") command

Execute the absolute motion of each axis.

This command corresponds to DRIVEA instruction of PacScript language.

This method is not available when a license key of b-CAP Slave is added and the robot is controlled by a client as a b-CAP SlaveMode.

Syntax DriveAEx (<vntPoses> [, < strOpt >])

vntPoses	:	[in] Axis number and distance (POSEDATA type, C3 format) Specify the desired axes and axis coordinates in POSEDATA type for eight axes at the maximum.
strOpt	:	[in] Motion option (VT_BSTR) [SPEED=n][,ACCEL=n][,DECEL=n][,TIME=n][,NEXT] SPEED (S): Specify the movement speed. The meaning is the same as the SPEED statement. ACCEL: Specify the acceleration. The meaning is the same as the ACCEL statement. DECEL: Specify the deceleration. The meaning is the same as the DECEL statement. TIME: Specify the time to activate the motion. NEXT: Asynchronous execution option.
Return value	:	None

Example

```

vntPose1 = Array(Array(1, 10), -1, "@0")
vntPose2 = Array(Array(2, 10), -1)
vntPoses = Array(vntPose1, vntPose2)
caoRob.Execute "DriveAEX", Array(vntPoses, "S=10, NEXT")
caoRob.Execute "DriveAEX", Array("@0 (1,10), (2,10)", "S=10, NEXT")

```

5.2.29.53. CaoRobot::Execute("RotateH") command

Execute rotary motion by taking an approach vector as an axis.

This command corresponds to ROTATEH instruction of PacScript language.

This method is not available when a license key of b-CAP Slave is added and the robot is controlled by a client as a b-CAP SlaveMode.

Syntax RotateH (<vntPoseAxis> [,<strOpt>])

vntPoseAxis	:	[in] Relative rotation angle around approach vector (POSEDATA type, C2 format) "[Pass start displacement]<Value (degree)>"
strOpt	:	[in] Motion option (VT_BSTR) [SPEED=n][,ACCEL=n][,DECEL=n][,TIME=n][,NEXT] SPEED (S): Specify the movement speed. The meaning is the same as the SPEED statement. ACCEL: Specify the acceleration. The meaning is the same as the ACCEL statement. DECEL: Specify the deceleration. The meaning is the same as the DECEL statement. TIME: Specify the time to activate the motion. NEXT: Asynchronous execution option.
Return value	:	None

Example

```
-----
caoRob.Execute"RotateH", Array("@P 32.5" ,"S=50" )
-----
```

5.2.29.54. CaoRobot::Execute("Arrive") command

Wait for the robot to reach the defined motion ratio.

This command corresponds to ARRIVE instruction of PacScript language.

This method is not available when a license key of b-CAP Slave is added and the robot is controlled by a client as a b-CAP SlaveMode.

Syntax Arrive (<Motion ratio>)

Argument	:	[in] (VT_R4) Motion ratio
Return value	:	None

Example

```
caoRob.Move 1,"P1","Next" ' Asynchronous execution
caoRob.Execute"Arrive", 50 ' Wait for 50% completion
```

5.2.29.55. CaoRobot::Execute("MotionSkip") command

Abort the robot motion in progress.

This command corresponds to MOTIONSKIP instruction of PacScript language.

This method is not available when a license key of b-CAP Slave is added and the robot is controlled by a client as a b-CAP SlaveMode.

Syntax MotionSkip ([<ArmGroup>[, <Parameter>]])

ArmGroup	:	[in] Arm group number (VT_I4) -1 (default): Current arm group under control
Parameter	:	[in] Operation continuation pattern (VT_I4) 0 (default): Specify the pass start displacement as @0 and connect it with the maximum deceleration. 1: Specify the pass start displacement as @P and connect it with the maximum deceleration. 2: Specify the pass start displacement as @0 and connect it with the set deceleration. 3:1: Specify the pass start displacement as @P and connect it with the set deceleration.
Return value	:	None

Example

```
caoRob.Execute "MotionSkip", Array(0, 1)
```

5.2.29.56. CaoRobot::Execute("MotionComplete") command

Judge whether the robot motion command or robot motion is complete.

This command corresponds to MOTIONCOMPLETE instruction of PacScript language.

Syntax MotionComplete ([<ArmGroup> [,<Mode>]])

ArmGroup	:	[in] Arm group number (VT_I4) -1 (default): Current arm group under control
Mode	:	[in] Mode 0 (default): Get motion command completion status 1: Get motion completion status

Return value : [out] Status <VT_BOOL>
 in Mode 0
 Operation command is complete: VARIANT_TRUE,
 Running, suspended, continue-stopped: VARIANT_FALSE
 in Mode 1
 Robot stopped: VARIANT_TRUE,
 Robot running: VARIANT_FALSE

Example Asynchronous motion and wait for completion

```
-----
caoRob.Move 1,"P1","Next" ' Asynchronous motion to P1
Do
  '<Processing during movement>

Loop While( Not caoRob.Execute("MotionComplete", Array(-1, 1) )) ' Operation completion check
-----
```

5.2.29.57. CaoRobot::Execute("CurTool") command

Get the current tool number.

Syntax CurTool ()

Argument : None
 Return value : Current tool number (VT_I4)

Example

```
-----
Debug.Print caoRob.Execute("CurTool")
-----
```

5.2.29.58. CaoRobot::Execute("GetToolDef") command

Get the tool definition specified by the tool number.

Syntax GetToolDef (<ToolNo>)

ToolNo : [in] Tool number (VT_I4)
 Return value : Tool definition (VT_R8|VT_ARRAY)
 X, Y, Z, RX, RY, RZ

Example

```
-----
Dim vVal As Variant
vVal = caoRob.Execute("GetToolDef", 1)
Debug.Print "X= " & vVal(0) & ", Y= " & vVal(1) & ", Z= " & vVal(2)
Debug.Print "RX= " & vVal(3) & ", RY= " & vVal(4) & ", RZ= " & vVal(5)
-----
```

5.2.29.59. CaoRobot::Execute("SetToolDef") command

Set the tool definition.

This method is not available when a license key of b-CAP Slave is added and the robot is controlled by a client as a b-CAP SlaveMode.

Syntax SetToolDef (<ToolNo>, <ToolDef>)

ToolNo	:	[in] Tool number (VT_I4)
ToolDef	:	[in] Tool definition (P type Fig is ignored.) X, Y, Z, RX, RY, RZ
Return value	:	None

Example

```
-----
caoRobot.Execute "SetToolDef", Array(1, "P2")
caoRobot.Execute "SetToolDef", Array(2, "P(100, 200, 300, 180, 0, 180)")
-----
```

5.2.29.60. CaoRobot::Execute("CurWork") command

Get the current work number.

Syntax CurWork ()

Argument	:	None
Return value	:	Current work number (VT_I4)

Example

```
-----
Debug.Print caoRob.Execute( "CurWork")
-----
```

5.2.29.61. CaoRobot::Execute("GetWorkDef") command

Get the work definition specified by the work number.

Syntax GetWorkDef (<WorklNo>)

WorkNo	:	[in] Work number (VT_I4)
Return value	:	Work definition (VT_R8 VT_ARRAY) X, Y, Z, RX, RY, RZ, attributes

Example

```
-----
Dim vVal As Variant
vVal = caoRob.Execute("GetWorkDef", 1)
Debug.Print"X= " & vVal(0) & ", Y= " & vVal(1) & ", Z= " & vVal(2)
Debug.Print"RX= " & vVal(3) & ", RY= " & vVal(4) & ", RZ= " & vVal(5)
Debug.Print"ATTR= " & vVal(6)
-----
```

5.2.29.62. CaoRobot::Execute("SetWorkDef") command

Set the work definition.

This method is not available when a license key of b-CAP Slave is added and the robot is controlled by a client as a b-CAP SlaveMode.

Syntax SetWorkDef (<WorkNo>, <WorkDef><WorkAttribute>)

WorkNo	:	[in] Work number (VT_I4)
WorkDef	:	[in] Work definition (P type Fig is ignored.) X, Y, Z, RX, RY, RZ
WorkAttribute	:	[in] Work attribute (VT_I4) (If it is omitted, 0 is specified.) 0:Standard(default) 1:FixedTool(Fix)
Return value	:	None

Example

```
-----
caoRobot.Execute "SetWorkDef", Array(1, "P2")
caoRobot.Execute "SetWorkDef", Array(2, "P(100, 200, 300, 180, 0, 180)")
-----
```

5.2.29.63. CaoRobot::Execute("WorkAttribute") command

Get work attribute specified by a work number

Syntax WorkAttribute (<WorkNo>)

WorkNo	:	[in] Work number (VT_I4)
Return value	:	Work attribute (VT_I4)

Example

```
-----
Dim vVal As Variant
vVal = caoRob.Execute("WorkAttribute", 1)
-----
```

5.2.29.64. CaoRobot::Execute("GetAreaDef") command

Get the area definition with the specified area number.

Syntax GetAreaDef (<AreaNo>)

Argument : [in] Area number (VT_I4)
 Return value : Area definition (VT_R8|VT_ARRAY)
 X,Y,Z,RX,RY,RZ,DX,DY,DZ,IO,Position,Error,Time,DRX,DRY,
 DRZ,Margin,Position1,Margin1,Position2,Margin2,Position3,
 Margin3,Position4,Margin4,Position5,Margin5,Position6,Margin6,
 Position7,Margin7,Position8,Margin8,Enable

Example

```
-----
Debug.Print caoRob.Execute("GetAreaDef", 1)
-----
```

5.2.29.65. CaoRobot::Execute("SetAreaDef") command

Set the area parameter.

This method is not available when a license key of b-CAP Slave is added and the robot is controlled by a client as a b-CAP SlaveMode.

Syntax1 SetAreaDef (<Area number>, <Center>, <Size>, <I/O number>, <Variable storage number>[,<Area detection setting>])

Syntax2 SetAreaDef (<Area number>, <Area definition>)

Argument : **Syntax 1**:
 [in] Area number (VT_I4)
 [in] Position and rotation (inclination) of center point (P type)
 [in] Area size (V type)
 [in] I/O number (VT_I4)
 [in] Variable storage number (VT_I4)
 [in] Area detection setting (VT_I4)
Syntax2:
 [in] Area definition (VT_R8|VT_ARRAY)
 X,Y,Z,RX,RY,RZ,DX,DY,DZ,IO,Position[,Error,Time,DRX,DRY,
 DRZ,Margin,Position1,Margin1,Position2,Margin2,Position3,
 Margin3,Position4,Margin4,Position5,Margin5,Position6,Margin6,
 Position7,Margin7,Position8,Margin8,Enable]
 Return value : None

Example

```
-----  
caoRobot.Execute "SetAreaDef", Array(1, "P0", "V0", 24, 0, 0)  
caoRobot.Execute "SetAreaDef", Array(2, "P(400, 250, 140, 180, 0, 180)", "V(200, 125, 70)", 24, 0, 0)  
-----
```

5.2.29.66. CaoRobot::Execute("SetArea") command

Enable the area check.

This method is not available when a license key of b-CAP Slave is added and the robot is controlled by a client as a b-CAP SlaveMode.

Syntax SetArea (<AreaNum>)

<AreaNum> : Area number (VT_I4)
Return value : None

Example

```
-----  
caoRobot.Execute "SetArea", 1  
-----
```

5.2.29.67. CaoRobot::Execute("ResetArea") command

Disable the area check.

This method is not available when a license key of b-CAP Slave is added and the robot is controlled by a client as a b-CAP SlaveMode.

Syntax ResetArea (<AreaNum>)

<AreaNum> : Area number (VT_I4)
Return value : None

Example

```
-----  
caoRobot.Execute "ResetArea", 1  
-----
```

5.2.29.68. CaoRobot::Execute("AreaSize") command

Return the size (each side length) of a check area as the vector type.

Syntax AreaSize (<AreaNum>)

<AreaNum>	:	Area number (VT_I4)
Return value	:	Area size (VT_R8 VT_ARRAY) X,Y,Z

Example

```
Dim vVal As Variant
vVal = caoRob.Execute("AreaSize", 1) ' Get size of Area1
Debug.Print "X= " & vVal(0) & ", Y= " & vVal(1) & ", Z= " & vVal(2)
```

5.2.29.69. CaoRobot::Execute("GetAreaEnabled") command

Get the area enabled or disabled status.

Syntax GetAreaEnabled (<AreaNum>)

<AreaNum>	:	[in] Area number (VT_I4)
Return value	:	Enabled/disabled (VT_BOOL)

Example

```
Debug.Print caoRob.Execute("GetAreaEnabled", 1) ' Get enabled/disabled status of Area1
```

5.2.29.70. CaoRobot::Execute("SetAreaEnabled") command

Set the area enabled or disabled status.

This method is not available when a license key of b-CAP Slave is added and the robot is controlled by a client as a b-CAP SlaveMode.

Syntax SetAreaEnabled (<AreaNum>, <Enable/disable>)

<AreaNum>	:	[in] Area number (VT_I4)
<Enable/disable>	:	[in] Area number (VT_BOOL)
Return value	:	None

Example

```
caoRob.Execute "SetAreaEnabled", Array( 1, True ) ' Set Area1 enabled
```

5.2.29.71. CaoRobot::Execute("AddPathPoint") command

Add a path point to the path data.

This method is not available when a license key of b-CAP Slave is added and the robot is controlled by a client as a b-CAP SlaveMode.

If the path number that you have specified already has different path points, the newly specified path points will be added after the existing path points.

This command is compatible with SetSplinePoint command of NetwoRC provider (provider for RC7 controller).

Syntax AddPathPoint (<PathNum>, < Pose >)

< PathNum >	:	[in] Path number(1 to 20) (VT_I4)
< Pose >	:	[in] POSEDATA value (one of P, J, and T types)
Return value	:	None

Example

```
-----  
caoRobot.Execute "AddPathPoint", Array(2, "P(400, 250, 140, 180, 0, 180)")  
-----
```

5.2.29.72. CaoRobot::Execute("ClrPathPoint") command

Clear the whole path points at the specified path.

This method is not available when a license key of b-CAP Slave is added and the robot is controlled by a client as a b-CAP SlaveMode.

This command is compatible with ClrSplinePoint command of NetwoRC provider (provider for RC7 controller).

Syntax ClrPathPoint (<PathNum>)

< PathNum >	:	[in] Path number(1 to 20) (VT_I4)
Return value	:	None

Example

```
-----  
caoRobot.Execute "ClrPathPoint", 2  
-----
```

5.2.29.73. CaoRobot::Execute("GetPathPoint") command

Return a position data of specified path point.

This command is compatible with GetSplinePoint command of NetwoRC provider (provider for RC7 controller).

Syntax GetPathPoint (<PathNum>, <PointNum>)

< PathNum >	:	[in] Path number(1 to 20) (VT_I4)
< PointNum >	:	[in] Path point number(1 to 5000) (VT_I4)
Return value	:	P type(VT_VARIANT[VT_R8 VT_ARRAY:7 element])

Example

```
-----
Dim vntPos as Variant
vntPos = caoRobot.Execute("GetPathPoint", Array(2, 1))
-----
```

5.2.29.74. CaoRobot::Execute("LoadPathPoint") command

Load a path data.

This method is not available when a license key of b-CAP Slave is added and the robot is controlled by a client as a b-CAP SlaveMode.

Clear the path data of the specified path number, and then read out the path data stored in the data storage memory.

This command corresponds to LOADPATHPOINT instruction of PacScript language

Syntax LoadPathPoint (<PathNum>)

< PathNum >	:	[in] Path number(1 to 20) (VT_I4)
Return value	:	None

Example

```
-----
caoRobot.Execute "LoadPathPoint", 2
-----
```

5.2.29.75. CaoRobot::Execute("GetPathPointCount ") command

Return the number of path points at the specified path.

This command corresponds to GETPATHPOINTCOUNT instruction of PacScript language

Syntax GetPathPointCount (<PathNum>)

< PathNum > : [in] Path number(1 to 20) (VT_I4)
Return value : Number of path points (VT_I4)

Example

```
-----  
Dim ICount As Long  
ICount = caoRobot.Execute("GetPathPointCount", 2)  
-----
```

5.2.29.76. CaoRobot::Execute("GetRobotTypeName") command

Get the robot type.

Syntax GetRobotTypeName ()

Argument : None
Return value : Robot type (VT_BSTR)

Example

```
-----  
Debug.Print caoRob.Execute("GetRobotTypeName" )  
-----
```

5.2.29.77. CaoRobot::Execute("ArchMove") command

Perform an arch motion.

This command corresponds to ARCHMOVE instruction of PacScript language.

This method is not available when a license key of b-CAP Slave is added and the robot is controlled by a client as a b-CAP SlaveMode.

Syntax ArchMove (<TgtPose>,<Hight>[,<ArchStartPos>,<ArchEndPos>])

< TgtPose >	:	[in] Target position (VT_I4)
< Hight >	:	[in] Height[mm] (VT_R4)
< ArchStartPos >	:	[in] Arch start position[mm] (VT_R4) If the argument is omitted, 0 is assumed to be specified.
< ArchEndPos >	:	[in] Arch finish position[mm] (VT_R4) If the argument is omitted, 0 is assumed to be specified.
Return value	:	None

Example

```
-----
caoRobot.Execute "ArchMove",Array( "P10",50,30,30 )
-----
```

5.2.29.78. CaoRobot::Execute("CrtMotionAllow") command

Change the stop positional precision and postural precision settings of Move @C command.

This command corresponds to CRTMOTIONALLOW instruction of PacScript language.

This method is not available when a license key of b-CAP Slave is added and the robot is controlled by a client as a b-CAP SlaveMode.

Syntax1 CrtMotionAllow (<True>,<Position>[,<Posture>])

Syntax2 CrtMotionAllow (<False>)

< True/False >	:	[in] True/False (VT_I4) True (other than 0) or False (0)
< Position >	:	[in] Positional precision [mm] (VT_R4)
< Posture >	:	[in] Postural precision [degree] (VT_R4)
Return value	:	None

Example

```
-----
caoRobot.Execute "CrtMotionAllow", Array(True, 1, 1 )
caoRobot.Move 1, "@C J2"
caoRobot.Execute "CrtMotionAllow", False
-----
```

5.2.29.79. CaoRobot::Execute("EncMotionAllow") command

With Move @E, change the "Allowable angle in stop state" of each axis for robot axis used for stop judgement.

This command corresponds to ENCMOTIONALLOW instruction of PacScript language.

This method is not available when a license key of b-CAP Slave is added and the robot is controlled by a client as a b-CAP SlaveMode.

Syntax1 EncMotionAllow (<True>,<Angle>[,<Mode>])

Syntax2 EncMotionAllow (<False>)

< True/False >	:	[in] True/False (VT_I4) True (other than 0) or False (0)
< Angle >	:	[in] Allowable angle (VT_R4)
< Mode >	:	[in] Mode value (VT_I4) 0: [degree] or [mm](default) 1: [pulse]
Return value	:	None

Example

```
-----
caoRobot.Execute "EncMotionAllow", Array(True, 1, 1 )
caoRobot.Move 1, "@E J2"
caoRobot.Execute "EncMotionAllow", False
-----
```

5.2.29.80. CaoRobot::Execute("EncMotionAllowJnt") command

With Move @E, change the "Allowable angle in stop state" of the axis for other than robots' axis used for stop judgement.

This command corresponds to ENCMOTIONALLOWJNT instruction of PacScript language.

This method is not available when a license key of b-CAP Slave is added and the robot is controlled by a client as a b-CAP SlaveMode.

Syntax1 EncMotionAllowJnt (<True>,<Axis>,<Angle>[,<Mode>])

Syntax2 EncMotionAllowJnt (<False>,<Axis>)

< True/False >	:	[in] True/False (VT_I4) True (other than 0) or False (0)
< Axis >	:	[in] Axis number (VT_R4)
< Angle >	:	[in] Allowable angle (VT_R4)
< Mode >	:	[in] Mode value (VT_I4) 0: [degree] or [mm](default)

1: [pulse]
 Return value : None

Example

```
-----
caoRobot.Execute "EncMotionAllowJnt", Array(True, 7, 0.01, 1)
caoRobot.Move 1, "@E J2 EXA(7, 30.5)"
caoRobot.Execute "EncMotionAllowJnt", Array(False, 7)
-----
```

5.2.29.81. CaoRobot::Execute("ErAlw") command

Set the deviation tolerance function and True/False the function.

This command corresponds to ERALW instruction of PacScript language.

This method is not available when a license key of b-CAP Slave is added and the robot is controlled by a client as a b-CAP SlaveMode.

Syntax1 ErAlw (<True>,<Axis>,<Value>)

Syntax2 ErAlw (<False>,<Axis>)

< True/False > : [in] True/False (VT_I4)
 True (other than 0) or False (0)
 < Axis > : [in] Axis number (VT_I4)
 < Value > : [in] Setting value ([degree] or [mm]) (VT_R4)
 Return value : None

Example

```
-----
caoRobot.Execute "ErAlw", Array(True, 1, 0.01)
caoRobot.Execute "ErAlw", Array(True, 2, 0.01)
caoRobot.Execute "ErAlw", Array(False, 0)
-----
```

5.2.29.82. CaoRobot::Execute("ForceCtrl") command

Enable/disable the force control function (compliance function).

This command corresponds to FORCECTRL instruction of PacScript language.

This method is not available when a license key of b-CAP Slave is added and the robot is controlled by a client as a b-CAP SlaveMode.

Syntax1 ForceCtrl (<True>,<CtrlNum>)

Syntax2 ForceCtrl (<False>)

< True/False > : [in] True/False (VT_I4)
 True (other than 0) or False (0)

< CtrlNum >	:	[in] Force Control Number(1 to 10) (VT_I4)
< Mode >	:	[in]Control mode [VT_I4] 0: Compliance Function 1: Compliance Function with Force sensor If it is omitted, the value is determined according to the parameter table number for compliance function.
Return value	:	None

Example

```
caoRobot.Execute "ForceCtrl", Array(True, 1)
caoRobot.Execute "ForceCtrl", False
```

5.2.29.83. CaoRobot::Execute("ForceParam") command

Set parameters for force control function (compliance function).

This command corresponds to FORCEPARAM instruction of PacScript language.

This method is not available when a license key of b-CAP Slave is added and the robot is controlled by a client as a b-CAP SlaveMode.

Syntax ForceParam (<CtrlNum>,<Coordinates>,<Force>,[<PosEralw>],[<Spring>],[<Damp>],[<Mass>],[<CurLmt>],[<OffSet>],[<Eralw>,[<IMode>],[<Rate>],[<SpMax>,<RSpMax>]]]]]]]]))

< CtrlNum >	:	[in] Force Control Number(1 to 10) (VT_I4)
< Coordinates >	:	[in] Coordinates (VT_I4) 0: base coordinates 1: tool coordinates 2: work coordinates
< Force >	:	[in] Force [P type]
< PosEralw >	:	[in] Allowable Position Deviation [P type]
< Spring >	:	[in] Compliance [P type]
< Damp >	:	[in] Damping [P type]
< Mass >	:	[in] Inertia [P type]
< CurLmt >	:	[in] Current Limit Value [J type]
< OffSet >	:	[in] Offset Value [P type]
< Eralw >	:	[in] Allowable Axis Deviation [J type]
<IMode>	:	[in] Speed control mode [VT_I4] (Reserved area for future use. Specify "0")
<Rate>	:	[in]Control rate [P type]

<SpMax> : [in]Maximum translation speed [VT_R8]
 <RSpMax> : [in]Maximum rotation speed [VT_R8]
 Return value : None

Example

```
-----
caoRobot.Execute "ForceParam", Array(1, 1, "P10")
-----
```

5.2.29.84. CaoRobot::Execute("ForceValue") command

Get values of force control specified by arguments.

Syntax ForceValue (<DataNo> [,<Mode>])

< DataNo > : [in]Data number [VT_I4]
 0: Sensor value [N|Nm]. Get the sensor value on the control coordinatesystem as P type..
 1: Sensor value [pulse] Get the sensor output value as P type.
 2: The positive peak of the force and moment on the control coordinate system [N|Nm]
 3: The negative peak of the force and moment on the control coordinate system [N|Nm]
 4: Travel distance of the tool end from the control start position on the control coordinate system. (command value) [mm|deg]
 5: Positive peak of the tool end's travel distance from the control start position on the control coordinate system (command value) [mm|deg]
 6: Negative peak of the tool end's travel distance from the control start position on the control coordinate system (command value)[mm|deg]
 7: Travel distance of the tool end from the control start position on the control coordinate system. (current value) [mm|deg]
 8: Positive peak of the tool end's travel distance from the control start position on the control coordinate system (current value) [mm|deg]
 9: Negative peak of the tool end's travel distance from the control start position on the control coordinate system (current value) [mm|deg]

	10: Deviation between the command value and the force control command value that occurs from the force control start, on the control coordinate system. [mm deg]
	11: Positive peak in the deviation between the command value and the force control command value that occurs from the force control start, on the control coordinate system. [mm deg]
	12: Negative peak in the deviation between the command value and the force control command value that occurs from the force control start, on the control coordinate system. [mm deg]
< Mode >	: [in]Mode [VT_I4] 0: Get data -1: Reset the peak value If it is omitted, 0 is assumed to be specified.
Return value	: [out] Value of force control [VT_VARIANT] If Mode is "0": A force control value according to the data number If Mode is "-1" : Value immediately before the reset

Example

```
vntVal = caoRobot.Execute("ForceValue", Array(1, 0))
```

5.2.29.85. CaoRobot::Execute("ForceWaitCondition") command

Wait until the condition specified by the force control is satisfied.

This method is not available when a license key of b-CAP Slave is added and the robot is controlled by a client as a b-CAP SlaveMode.

Syntax ForceWaitCondition ([<Position> [,<Force> [,<Time> [,<Mode> [,<Timeout>]]]])

< Position >	: [in]Travel distance [P type] Set the travel distance of the tool end from the control start position. [mm], [deg] If it is omitted, "-1" is assumed to be specified.
<Force>	: [in]Force and moment [P type] Set the force and moment converted to the force control coordinate system. [N],[Nm] If it is omitted, "-1" is assumed to be specified.

- <Time> : [in]Elapsed time [VT_I4]
Set the elapsed time from the control start.[ms]
If it is omitted, "-1" is assumed to be specified.
- <Mode> : [in]Termination mode
Set the termination mode for the robot and force control when the condition is met.
0:Neither the robot motion nor force control is terminated.
1:The robot immediately stops. (Halt) Force control is not terminated.
2:Both the robot motion and force control are terminated.
If it is omitted, 0 is assumed to be specified.
- <Timeout> : [in] Timeout period [VT_I4]
Specify the timeout period [ms].

Example

```
caoRobot.Execute "ForceWaitCondition", Array("P0","P1")
```

5.2.29.86. CaoRobot::Execute("ForceSensor") command

Control the force sensor

This method is not available when a license key of b-CAP Slave is added and the robot is controlled by a client as a b-CAP SlaveMode.

Syntax ForceSensor (<FuncNo>)

- < FuncNo> : [in] Function number [VT_I4]
0:Force sensor reset

Example

```
caoRobot.Execute "ForceSensor", 0
```

5.2.29.87. CaoRobot::Execute("ForceChangeTable") command

Change the force control table which is currently controlled.

This method is not available when a license key of b-CAP Slave is added and the robot is controlled by a client as a b-CAP SlaveMode.

Syntax ForceChangeTable (< TableNo >)

< Table No > : [in] Table number (1-10) [VT_I4]

Example

```
-----
caoRobot.Execute "ForceChangeTable", 1
-----
```

5.2.29.88. CaoRobot::Execute("GetSrvData") command

Return the servo internal data of the robot axis.

This command corresponds to GETSRVDATA instruction of PacScript language

Syntax GetSrvData (<DataNum>)

< DataNum > : [in] Data number(1,2,4,5,7,8,17,18,19,20) (VT_I4)

Return value : Servo internal data
(J type (VT_VARIANT[VT_R8|VT_ARRAY:8 element]))

- 1: Current motor speed value (rpm)
- 2: Motor angle deviation (mm or deg)
- 4: Absolute motor current value (Rated ratio %)
- 5: Motor torque command position (excluding dead weight compensation) (Rated ratio %)
- 7: Load factor (%)
- 8: Each axial position and angle command position (mm or deg)
- 17: Tool tip speed [work coordinates] (mm/s)
* Position: Only 3 Components are obtained.
- 18: Tool tip deviation [work coordinates] (mm)
* Position: Only 3 Components are obtained.
- 19: Tool tip speed [tool coordinates] (mm/s)
* Position: Only 3 Components are obtained.
- 20: Tool tip deviation [tool coordinates] (mm)
* Position: Only 3 Components are obtained.

Example

```
-----
Dim vntVal As Variant
vntVal = caoRobot.Execute("GetSrvData", 2)
-----
```

5.2.29.89. CaoRobot::Execute("GetSrvJntData") command

Return the servo internal data of the specified axis.

This command corresponds to GETSRVJNTDATA instruction of PacScript language

Syntax GetSrvJntData (<DataNum>,<Axis>)

< DataNum >	:	[in] Data number(1,2,4,5,8) (VT_I4)
< Axis >	:	[in] Axis number (VT_I4)
Return value	:	Servo internal data (VT_R4)
		1: Current motor speed value (rpm)
		2: Motor angle deviation (mm or deg)
		4: Absolute motor current value (Rated ratio %)
		5: Motor torque command position (excluding dead weight compensation) (Rated ratio %)
		8: Each axial position and angle command position (mm or deg)

Example

```
Dim fData As Single
fData = caoRobot.Execute("GetSrvJntData", 2, 1)
```

5.2.29.90. CaoRobot::Execute("GrvCtrl") command

Configure True/False of Gravity Compensation Control Function.

This command corresponds to GRVCTRL instruction of PacScript language

This method is not available when a license key of b-CAP Slave is added and the robot is controlled by a client as a b-CAP SlaveMode.

Syntax GrvCtrl (<True/False>)

< True/False >	:	[in] True/False (VT_I4)
		True (other than 0) or False (0)
Return value	:	None

Example

```
caoRobot.Execute "GrvCtrl", True
caoRobot.Execute "GrvCtrl", False
```

5.2.29.91. CaoRobot::Execute("CurLmt") command

Configure the current limiting function and True/False.

This command corresponds to CURLMT instruction of PacScript language.

This method is not available when a license key of b-CAP Slave is added and the robot is controlled by a client as a b-CAP SlaveMode.

Syntax1 CurLmt (<True>,<Axis>,<Value>)

Syntax2 CurLmt (<False>,<Axis>)

< True/False >	:	[in] True/False (VT_I4) True (other than 0) or False (0)
< Axis >	:	[in] Axis number (VT_R4) 0: All axes(When set to false)
< Value >	:	[in] Setting value(1 to 100[%]) (VT_R4)
Return value	:	None

Example

```
caoRobot.Execute "GrvCtrl", True
caoRobot.Execute "CurLmt", Array(True, 1, 10.5)
caoRobot.Execute "CurLmt", Array(True, 2, 50.3)
caoRobot.Execute "CurLmt", Array(False, 0)
caoRobot.Execute "GrvCtrl", False
```

5.2.29.92. CaoRobot::Execute("Zforce") command

Specify the thrust force for current limiting function of the third axis (Z axis) in H Series Robot.

This command corresponds to ZFORCE instruction of PacScript language.

This method is not available when a license key of b-CAP Slave is added and the robot is controlled by a client as a b-CAP SlaveMode.

Syntax Zforce (<Thrust>)

< Thrust >	:	[in] Thrust force (VT_R4)
Return value	:	None

Example

```
caoRobot.Execute "GrvCtrl", True
caoRobot.Execute "Zforce", 50
caoRobot.Execute "GrvCtrl", False
```

5.2.29.93. CaoRobot::Execute("GrvOffset") command

Configure True/False of gravity offset function.

This command corresponds to GRVOFFSET instruction of PacScript language.

This method is not available when a license key of b-CAP Slave is added and the robot is controlled by a client as a b-CAP SlaveMode.

Syntax GrvOffset (<True/False>)

< True/False > : [in] True/False (VT_I4)
 True (other than 0) or False (0)

Return value : None

Example

```
caoRobot.Execute "GrvOffset", True
caoRobot.Execute "GrvOffset", False
```

5.2.29.94. CaoRobot::Execute("HighPathAccuracy") command

Switch True/False of the high tracing control function.

This command corresponds to HIGHPATHACCURACY instruction of PacScript language.

This method is not available when a license key of b-CAP Slave is added and the robot is controlled by a client as a b-CAP SlaveMode.

Syntax1 HighPathAccuracy (<True/False>)

< True/False > : [in] True/False (VT_I4)
 True (other than 0) or False (0)

Return value : None

Example

```
caoRobot.Execute "HighPathAccuracy", True
caoRobot.Execute "HighPathAccuracy", False
```

5.2.29.95. CaoRobot::Execute("MotionTimeout") command

Change a timeout setting value of the motion instruction.

This command corresponds to MOTIONTIMEOUT instruction of PacScript language.

This method is not available when a license key of b-CAP Slave is added and the robot is controlled by a client as a b-CAP SlaveMode.

Syntax1 MotionTimeout (<True>,<Timeout>)

Syntax2 MotionTimeout (<False>)

< True/False > : [in] True/False (VT_I4)
 True (other than 0) or False (0)

< Timeout > : [in] Timeout period (1 to 30000[msec]) (VT_I4)

Return value : None

Example

```
-----
caoRobot.Execute "MotionTimeout", Array(True, 1000)
caoRobot.Execute "MotionTimeout", False
-----
```

5.2.29.96. CaoRobot::Execute("SingularAvoid") command

Enable or disable singularity avoidance function.

This command corresponds to SINGULARAVOID instruction of PacScript language.

This method is not available when a license key of b-CAP Slave is added and the robot is controlled by a client as a b-CAP SlaveMode.

Syntax SingularAvoid (<Mode>)

```
< Mode >           : [in] Mode (VT_I4)
                    : 0: Disable
                    : 2: Enable
Return value       : None
```

Example

```
-----
caoRobot.Execute "SingularAvoid", 2
caoRobot.Move 1, "@0 P2"
caoRobot.Execute "SingularAvoid", 0
-----
```

5.2.29.97. CaoRobot::Execute("SpeedMode") command

Change the optimal speed setting function.

This command corresponds to SPEEDMODE instruction of PacScript language.

This method is not available when a license key of b-CAP Slave is added and the robot is controlled by a client as a b-CAP SlaveMode.

Syntax SpeedMode (<Mode>)

```
< Mode >           : [in] Mode number (VT_I4)
                    : 0: Disable
                    : 1: Enable (PTP motion)
                    : 2: Enable (CP motion)
                    : 3: Enable (PTP and CP motion)
Return value       : None
```

Example

```
caoRobot.Execute "SpeedMode", 1
```

5.2.29.98. CaoRobot::Execute("PayLoad") command

Change the setting value of internal load conditions.

This command corresponds to PAYLOAD instruction of PacScript language.

This method is not available when a license key of b-CAP Slave is added and the robot is controlled by a client as a b-CAP SlaveMode.

Syntax PayLoad (<Payload>[,<Gravity>[,<Inertia>]])

< Payload >	:	[in] Mass of payload (VT_I4)
< Gravity >	:	[in] Payload center of gravity V type(VT_VARIANT[VT_R8 VT_ARRAY:3 element]) If the argument is omitted, 0 Vector(0,0,0) is assumed to be specified.
< Inertia >	:	[in] Payload center of gravity inertia V type(VT_VARIANT[VT_R8 VT_ARRAY:3 element]) If the argument is omitted, 0 Vector(0,0,0) is assumed to be specified.
Return value	:	None

Example

```
caoRobot.Execute "PayLoad", Array(2000, "V(0, 100, 150)", "V(0, 10, 10)")
```

5.2.29.99. CaoRobot::Execute("GenerateNonStopPath ") command

This command is exclusive to "the Non-stop motion calculator option."

See "Appendix D. Non-Stop Motion Calculator - Trajectory Generator Command for Non Stop Inspection " in detail.

Syntax GenerateNonStopPath (<Teaching Points>, <Area Information>, <Teaching Point Number>, <Total Speed Rate>, <Convergence Coefficient>)

< Teaching Points >	:	[in]Teaching Points [<Position > VT_ARRAY]
< Area Information >	:	[in] Area Information [<Area > VT_ARRAY]
< Teaching Point Number >	:	[in] Teaching Point Number [VT_I4]
<Total Speed Rate>	:	[in] Total Speed Rate [VT_R8] 0.0 - 1.0 This ratio is used to change the entire speed of Non-stop motion. This is equivalent to the external speed of robot.
<Convergence Coefficient>	:	[in] Convergence Coefficient [VT_R8] 0.0 to 1.0.

This factor is used to calculate the motion point by convergent calculation.

Specify "0.7" for normal use.

Return value : [out]Motion Points [<Position > | VT_ARRAY]

Example

```
vntMovePos = caoRobot..Execute( "GenerateNonStopPath", Array(vntTeachPos, vntArealInfo,
Ubound(vntTeachPos) + 1, 100.0 * 0.01, 0.7))
```

5.2.29.100. CaoRobot::Execute("RobInfo") command

Return the robot information

This command corresponds to the RobInfo command of PacScript.

Syntax RobInfo (<IIndex>)

< IIndex > : Index number (VT_I4)
 Return value : [out] Robot information

Index number	Robot information	Data type
0	A unique value assigned to each robot type	Integer type
1	Robot type	String type
2	The total distance of each axis traversed after shipment	Joint type
3	Robot ID	Integer type

Example

```
Dim RobotInfo as long
RobotInfo = caoRobot.Execute("RobInfo",0)
```

5.2.29.101. CaoRobot::Execute("SyncTimeStart") command

Declare that multiple robots start and stop their motion simultaneously. Hereafter, this operation is called "synchronous motion".

Syntax SyncTimeStart()

Argument : none
 Return value : none

Example

```

Dim caoRobot0 As CaoRobot
Dim caoRobot1 As CaoRobot

Set CaoRobot0 = caoCtrl.AddRobot("Robot0","ID=0")
Set CaoRobot1 = caoCtrl.AddRobot("Robot1","ID=1")

CaoRobot0.Execute "SyncTimeStart"
    caoRobot0.Move 1,"P1" 'Instruct the master robot to move to P1
    caoRobot1.Move 1,"P3" 'Instruct the slave robot to move to P3
caoRobot0.Execute "SyncTimeEnd" 'Start the synchronous motion of Robot0 and Robot1.

```

5.2.29.102. CaoRobot::Execute("SyncTimeEnd") command

Start the synchronous motion with multiple robots.

Syntax SyncTimeEnd(<1Option>)

<1Option> : Motion option (VT_I4)
0: none (This should be "0" if it is omitted.)
1: NEXT

Return value : none

Example

```

Dim caoRobot0 As CaoRobot
Dim caoRobot1 As CaoRobot

Set CaoRobot0 = caoCtrl.AddRobot("Robot0","ID=0")
Set CaoRobot1 = caoCtrl.AddRobot("Robot1","ID=1")

CaoRobot0.Execute "SyncTimeStart"
    caoRobot0.Move 1,"P1" 'Instruct the master robot to move to P1
    caoRobot1.Move 1,"P3" 'Instruct the slave robot to move to P3
caoRobot0.Execute "SyncTimeEnd",1 'Start synchronous motion of Robot0 and Robot1 with Next option.

```

5.2.29.103. CaoRobot::Execute("SyncMoveStart") command

Declare that multiple robots will work together to complete a task. Hereafter, this operation is called "cooperative motion". One robot is designated to the leader robot, others are designated to the follower robots. PTP motion is not available.

Syntax SyncMoveStart(<1FollowerRobotID>,<1FollowerRobotID>...)

<1FollowerRobotID> : Robot ID of the follower robot (VT_I4|VT_ARRAY)
Return value : none

Example

```

Dim caoRobot0 As CaoRobot

```

```

Dim caoRobot1 As CaoRobot

Set CaoRobot0 = caoCtrl.AddRobot("Robot0","ID=0")
Set CaoRobot1 = caoCtrl.AddRobot("Robot1","ID=1")

CaoRobot0.Execute "SyncMoveStart",Array(1)
    caoRobot0.Move 2,"J(0,45,90,0,45,0,0,0)" 'Instruct the leader robot to move to the specified position.
caoRobot0.Execute "SyncMoveEnd"      'Start the cooperative motion of Robot0 and Robot1

```

5.2.29.104. CaoRobot::Execute("SyncMoveEnd") command

Start the cooperative motion with multiple robots.

Syntax SyncMoveEnd(<1Option>)

<1Option> : Motion option (VT_I4)
0: none (This should be "0" if it is omitted.)
1: Next

Return value : none

Example

```

Dim caoRobot0 As CaoRobot
Dim caoRobot1 As CaoRobot

Set CaoRobot0 = caoCtrl.AddRobot("Robot0","ID=0")
Set CaoRobot1 = caoCtrl.AddRobot("Robot1","ID=1")

CaoRobot0.Execute "SyncMoveStart",Array(1)
    caoRobot0.Move 2,"J3" 'Instruct the leader robot to move to J3.
caoRobot0.Execute "SyncMoveEnd",1 'Start the cooperative motion of Robot0 and Robot1with Next option.

```

5.2.29.105. CaoRobot::Execute("SetBaseDef") command

Specify the base definition.

Syntax SetBaseDef(<1BaseNo>,<BaseDef>,<1BaseAttribute>)

<1BaseNo> : Base number (VT_I4)
<BaseDef> : Base definition (P-type)
X, Y, Z, RX, RY, RZ
<1BaseAttribute> : At present, this item is not used

Return value : None

Example

```

caoRobot.Execute "SetBaseDef", Array(1,"P2")
caoRobot.Execute "SetWorkDef",Array(1,"P(100,200,300,180,0,180)")

```

5.2.29.106. CaoRobot::Execute("GetBaseDef") command

Obtain the base definition.

Syntax GetBaseDef(<1BaseNo>)

<1BaseNo> : Base number (VT_I4)
 Return value : Base definition (VT_R8|VT_ARRAY)
 X, Y, Z, RX, RY, RZ, attribute

Example

```
Dim vVal As Variant
vVal = caoRobot.Execcute ("GetBaseDef",1)
```

5.2.29.107. CaoRobot::Execute("SetHandIO") command

Set I/O number, values, and range of Hand I/O.

Syntax SetHandIO(<1IONo>,<1value>,<1range>)

<1IONo> : The smallest Hand I/O number.(VT_I4)
 <1Value> : Values to be set. (VT_I4)
 <1Range> : Setting range (VT_I4)
 Return value : None

Example

```
caoRobot.Execcute "SetHandIO",Array(48,8,4)
```

5.2.29.108. CaoRobot::Execute("GetHandIO") command

Obtain IO number, range, and values of HandI/O.

Syntax GetHandIO(<1IONo>,<1Range>)

<1IONo> : The smallest Hand I/O number (VT_I4)
 <1Range> : Setting range (VT_I4)
 Return value : Values of Hand IO in the setting range (VT_I4)

Example

```
Dim IVal As Integer
IVal = caoRobot.Execcute ("GetHandIO",Array(48,,4)).
```

5.2.29.109. CaoRobot::Execcute("StartServoLog") command

Start servo logging.

Syntax StartServoLog()

Argument : none

Return value : none

Example

```
caoRobot.Execcute "StartServoLog"
```

5.2.29.110. CaoRobot::Execcute("ClearServoLog") command

Delete obtained servo log data.

Syntax ClearServoLog()

Argument : none

Return value : none

Example

```
caoRobot.Execcute "ClearServoLog"
```

5.2.29.111. CaoRobot::Execcute("StopServoLog") command

Stop servo logging

Syntax StopServoLog()

Argument : none

Return value : none

Example

```
caoRobot.Execcute "StopServoLog"
```

5.2.29.112. CaoRobot::Execcute("GetCtrlLogMaxTime") command

Get the duration of control logging.

Syntax GetCtrlLogMaxTime ()

Argument : none
Return value : Logging duration of the control log (VT_I4)

Example

Dim IVal As Integer
IVal = caoRobot.Execccute ("GetCtrlLogMaxTime")

5.2.29.113. CaoRobot::Execute("SetCtrlLogMaxTime") command

Set the duration of control logging.

Syntax SetCtrlLogMaxTime (ITime)

Argument : Logging duration to be set (VT_I4)
Return value : none

Example

caoRobot.Execccute "SetCtrlLogMaxTime",10

5.2.29.114. CaoRobot::Execute("GetCtrlLogInterval") command

Get the interval of control logs.

Syntax GetCtrlLogInterval ()

Argument : none
Return value : Logging interval of the control log(VT_I4)

Example

Dim IVal As Integer
IVal = caoRobot.Execccute ("GetCtrlLogInterval")

5.2.29.115. CaoRobot::Execute("SetCtrlLogInterval ") command

Set the interval of control logs.

Syntax SetCtrlLogInterval (ITime)

Argument : Logging interval to be set (VT_I4)
 Return value : none

Example

```
caoRobot.Execcute "SetCtrlLogInterval",8
```

5.2.29.116. CaoRobot::Execute("DetectOn ") command

Enable Detect function.

Syntax DetectOn (<IPortNo>, <IVarType>, <IStartNo>, <IMaxNum>, <IResultVarNo>, <IMode>)

<IPortNo> : Input signal port number to use as a trigger (VT_I4)
 <IVarType> : Data type to store (VT_I4)
 257: Position type
 258: Joint type
 259: Homogeneous Translation Type
 <IStartNo> : The smallest index number of the global variables to store
 <IMaxNum> : Number of data to be stored in the global variable
 <IResultVarNo > : Index number of the integer type global variable to store the count of
 input signals which become triggers during the command enabled.
 <IMode> : Input signal detection edge
 0 : Rising edge only (when omitted)
 1 : Falling edge only
 2 : Rising edge and falling edge
 Return value : none

Example

```
caoRobot.Execcute "DetectOn",Array(8, 257, 2, 10, 11)
```

5.2.29.117. CaoRobot::Execute("DetectOff ") command

Disable the Detect function and then store the data.

Syntax DetectOff (<IPortNo>, <IMode>)

<IPortNo> : Port number to be disabled its function (VT_I4)
 <IMode> : Input signal detection edge

0 : Rising edge only (when omitted)
 1: Falling edge only
 2 : Rising edge and falling edge

Return value : none

Example

```
caoRobot.Execccute "DetectOff",Array(8,0)
```

5.2.29.118. CaoRobot::Execute("GetPluralServoData ") command

Obtain multiple servo data at one time.

Syntax GetPluralServoData ()

Argument : none

Return value : Servo data (VT_VARIANT|VT_ARRAY)
 Current motor speed, Motor angle deviation, Absolute value of motor current, Instruction value of motor torque, Each axes position, Angle instruction value, Tool-end speed, Tool-end deviation

Example

```
Dim vVal As Variant
vVal = caoRobot.Execccute ("GetPluralServoData")
```

5.2.29.119. CaoRobot::Execute("AngularTrigger ") command

Switch ON/OFF the specified IO whenever a robot moves by a specified angle or distance.

Syntax AngularTrigger(<IVal>, <IJointNo>, <IPortNo>, <dwidth>, <IMode>, <dStartAngle>)

<IVal> : Valid/Invalid (VT_I4)
 True (other than 0) : Valid
 False (0) : Invalid

<IJointNo> : Target joint (VT_I4)

<IPortNo> : I/O number to turn ON/OFF (VT_I4)

<dWidth> : Motion distance (VT_R8)
 This should be 0 if this entry is omitted.
 Rotary joint: deg.
 Sliding joint : mm

<IMode> : Angle setting at command start

0 : Not specify a start angle
 1 : Specify a start angle

<dStartAngle> : Start angle (VT_R8)
 This should be the current angle or the current position if this entry is omitted.

Return value : none

Example

```
caoRobot.Execute "AngularTrigger",Array(True, 1, 24, 10)
```

5.2.29.120. CaoRobot::Execute("VirtualFence") command

Start or stop monitoring the virtual fence.

Syntax VirtualFence (<IVal>, <IModelID>)

<IVal> : Valid/Invalid (VT_I4)
 True(other than 0) : Valid
 False(0) : Invalid

<IModelID> : Model ID (VT_I4)

Return value : none

Example

```
caoRobot.Execute "VirtualFence",Array(True, 1)
```

5.2.29.121. CaoRobot::Execute("ExclusiveArea") command

Create or change an exclusive area.

Syntax ExclusiveArea (<IVal>, <Position>, <Size>)

<IVal> : Exclusive area number (VT_I4)

<Position> : Position (P type)

<Size> : Size (V type)

Return value : none

Example

```
caoRobot.Execute "ExclusiveArea",Array(1, "P0", "V0")
```

5.2.29.122. CaoRobot::Execute("SetExclusiveArea") command

Enable the exclusive area.

Syntax SetExclusiveArea (<IAreaNo >)

<IAreaNo> : Area number (VT_I4)

Return value : none

Example

```
caoRobot.Execcute "SetExclusiveArea", 1
```

5.2.29.123. CaoRobot::Execute("ResetExclusiveArea") command

Disable the exclusive area.

Syntax ResetExclusiveArea (<IAreaNo >)

<IAreaNo> : Area number (VT_I4)

Return value : none

Example

```
caoRobot.Execcute "ResetExclusiveArea", 1
```

5.2.29.124. CaoRobot::Execute("ExclusiveControlStatus") command

Obtain the exclusive control status.

Syntax ExclusiveControlStatus (<IMode>, <ICtrlNo>)

<IMode> : Mode that you want to obtain (VT_I4)

0 : Exclusive control validity state

1 : Exclusive control existing state

2 : Exclusive control wait state

<ICtrlNo> : Exclusive controller number (VT_I4)

Return value : State of the specified mode (VT_I4)

Set it to a corresponding bit of a 32-bit array to return

Returns "1" if the mode status is ON and "0" if OFF

Example

```
Dim IVal As Integer
IVal = g_caoRobot.Execute("ExclusiveControlStatus", Array(1, 2))
```

5.2.29.125. CaoRobot::Execute("GetAllSrvData") command

Obtain servo internal data at one time.

Syntax GetAllSrvData

Argument	:	None
Return value	:	Servo internal data (VT_VARIANT VT_ARRAY) Time stamp (us) : VT_R8 Each axes position, angle command value (mm or deg) : J type (VT_R8 VTARRAY) Each axes position, angle current value (mm or deg) : J type (VT_R8 VTARRAY) Motor angle deviation (mm or deg) : J type (VT_R8 VTARRAY) Current motor speed (rpm) : J type (VT_R8 VTARRAY) Absolute value of motor current (the rated value %) : J type (VT_R8 VTARRAY) Instruction value of motor torque (the rated value %) : J type (VT_R8 VTARRAY) Load (%) : J type (VT_R8 VTARRAY) Tool-end speed [work coordinates](mm/s) : J type (VT_R8 VTARRAY) * Position: Only 3 Components are obtained. Any other elements are 0 Tool-end deviation [work coordinates](mm) : J type (VT_R8 VTARRAY) * Position: Only 3 Components are obtained. Any other elements are 0 Tool-end speed [tool coordinates](mm/s) : J type (VT_R8 VTARRAY) * Position: Only 3 Components are obtained. Any other elements are

0
 Tool-end deviation [tool coordinates](mm) : J type (VT_R8 | VTARRAY)
 * Position: Only 3 Components are obtained. Any other elements are
 0

Example

```
Dim vntVal As Variant
vntVal = g_caoRobot.Execute("GetAllSrvData")
```

5.2.29.126. CaoRobot::Execute("CurForceParam") command

Obtain current parameters for force control function (compliance function).

Syntax CurForceParam (<<INo>>)

< INo > : Control Number (VT_I4)
 Return value : Current parameters for force control (VT_VARIANT | VT_ARRAY)
 Coordinates : [VT_I4]
 0: base coordinates
 1 : tool coordinates
 2: work coordinates
 Force : [P type]
 Allowable Position Deviation : [P type]
 Compliance : [P type]
 Damping : [P type]
 Inertia : [P type]
 Current Limit Value : [J type]
 Offset Value : [P type]
 Allowable Axis Deviation : [J type]
 Speed control mode : [VT_I4] (Obtain 0)
 Control rate : [P type]
 Maximum translation speed : [VT_R8]
 Maximum rotation speed : [VT_R8]

Example

```
Dim VntVal As Variant
g_caoRobot.Execute "TakeArm", Array(0, 0)
VntVal = g_caoRobot.Execute("CurForceParam",1) 'Obtain the setting of current parameters for force control
VntVal(1) = "P10" 'Change the force value
g_caoRobot.Execute "ForcaParam",Array(1,VntVal) 'Update the setting of force control
```

5.2.29.127. CaoRobot::Execute("GetLogCount") command

Get count of control log.

Syntax GetLogCount ()

Argument	:	None
Return value	:	Count (VT_I4)

Example

```
Dim ICnt As Long
ICnt = caoRobot.Execute("GetLogCount" )
```

5.2.29.128. CaoRobot::Execute("GetLogRecord") command

Get data of control log.

Syntax GetLogRecord (<IIndex>)

<IIndex>	:	Index number (VT_I4) 0 to <Count>-1
Return value	:	Details (VT_VARIANT[VT_VARIANT VT_ARRAY:39 elements]) [0-7]:J1-J8 Instruction value (VT_R8) [8-15]:J1-J8 Encoder value (VT_R8) [16-23]: J1-J8 Current value (VT_R8) [24-31]: J1-J8 Load factor (VT_R8) [32]: User data (VT_R8) [33]: Trace data (VT_I4) [34]: Program name (VT_BSTR) [35]: Line number (VT_I4) [36]: Elapsed time (start time)[ms] (VT_I4) [37]: Tool number (VT_I4) [38]: Work number (VT_I4)

Example

```

Dim ICnt As Long
ICnt = caoRobot.Execute("GetLogCount")
Dim i As Long
For i=0 To ICnt-1
    vDat = caoRobot.Execute("GetLogRecord", i)
    ' vDat(0) : J1 Inst, ...,vDat(7) : J8 Inst
    ' vDat(8) : J1 Enc, ...,vDat(15) : J8 Enc
    ' :
Next

```

5.2.29.129. CaoRobot::Execute("GetForceLogRecord") command

Get data of force control log.

Syntax GetForceLogRecord (<IIndex>)

<IIndex>	:	Index number (VT_I4) 0 to <Count>-1
Return value	:	Details (VT_VARIANT[VT_VARIANT VT_ARRAY:36 elements]) [0-6]: Position Instruction value (VT_R8) [7-13]: Position Encoder value (VT_R8) [14-19]: Force Sensor value (VT_R8) [20-25]: Displacement from control log start (Instruction) (VT_R8) [26-31]: Displacement from control log start (Encoder) (VT_R8) [32]: Force control effective state (VT_BOOL) [33]: Program IC (VT_I4) [34]: Program Name (VT_BSTR) [35]: Line number (VT_I4)

Example

```

Dim ICnt As Long
ICnt = caoRobot.Execute("GetLogCount")
Dim i As Long
For i=0 To ICnt-1
    vDat = caoRobot.Execute("GetForceLogRecord", i)
    ' vDat(0) , ...,vDat(6) : Position Instruction value
    ' vDat(7) , ...,vDat(13) : Position Encoder value
    ' :
Next

```

5.2.30. CaoRobot::Execute method (dedicated for COBOTTA)

The list shows available commands.

Table 5-11 List of commands of CaoRobot::Execute method (dedicated for COBOTTA)

Category	Command name	Function	Support Version	
Motion Preparation / Maintenance	AutoCal	Execute CALSET automatically at the startup.	2.8.0	P.167
	MotionPreparation	The motion preparation is performed automatically.	2.8.0	P.168
	GetMotionPreparationState	Obtain the motion preparation complete status.	2.8.0	P.168
Robot Status/Value Obtainment	GetMechaButtonState	Get the buttons state.	2.13.0	P.169
	ClearMechaButtonState	Resets the counter for the number of times the button is released.	2.13.0	P.170

5.2.30.1. CaoRobot::Execute("AutoCal") command

To execute CALSET automatically at the startup. This command performs the same behavior as AutoCal of PAC command.

To use the command, set the use condition parameter 252 "CALSET on start-up" to "1: DoNot" to stop the display of CALSET window at the startup of TP. Also, the start-up privilege should be set to Ethernet. For details on AutoCal, see the COBOTTA manual.

Format AutoCal

Argument : None
Return value : None

Example

```
'Processing set at the startup
caoRobot.Execute "AutoCal"
caoRobot.Execute "Motionpreparation"
```

5.2.30.2. CaoRobot::Execute("MotionPreparation") command

The motion preparation is performed automatically. This command performs the same behavior as MotionPreparation of PAC command.

※When safety data was sent to COBOTTA by using COBOTTA parameter tool, TP requires motion preparation because the parameters need to be confirmed. Therefore, this command cannot be executed immediately after the safety data was sent.

For details on MotionPreparation, see the COBOTTA manual.

Format MotionPreparation

Argument : None
Return value : None

Example

```
'Processing set at the startup
caoRobot.Execute "AutoCal"
caoRobot.Execute "Motionpreparation"
```

5.2.30.3. CaoRobot::Execute("GetMotionPreparationState") command

To obtain the motion preparation complete status. When it is not in the motion preparation complete status, robot motion by any other commands than AutoCal is not possible.

The motion preparation completed status will turn to incomplete status by safety error occurrence, emergency stop ON, protective stop ON, and sending of safety parameter.

Format GetMotionPreparationState

Argument : None
Return value : Complete status/incomplete status (VT_BOOL)

Example

```
'Recovery method from error occurrence, emergency stop ON, and protective stop ON

' Clear the emergency stop and protective stop
```



```
' Clear error
caoCtrl.Execute "ClearError"

'When motion preparation is incomplete, perform the motion preparation
Dim vbState
vbState = caoRobot.Execute("GetMotionPreparationState")
If vbState <> True Then
    caoRobot.Execute "MotionPreparation"
End If
```

5.2.30.4. CaoRobot::Execute("GetMechaButtonState ") command

To get the number of times a button on the arm of COBOTTA was pressed and the current state of the button. Number of times the button was pressed will be reset when executing the ClearMechaButtonState command and when turning off COBOTTA.

Format GetMechaButtonState< IBtnType>

< IBtnType >	:	Button type to get the state (VT_I4) 0 : Function button 1 : Gripper plus button 2 :Gripper minus button
Retrun value	:	Array of button states (VT_I4 VT_ARRAY) [0] : Number of times the button was pressed * The pressed number of the button is counted at the timing of the button is released. [1] : Button state 0 : Button is not pressed 1 : Button is pressed

Example

```
Dim vntRet As Variant
Dim ICnt As Integer
Dim IState As Integer
vntRet = caoRob.Execute("GetMechaButtonState", 0) ' Specify the function buttonFunction button
ICnt = vntRet(0) ' Number of times the button was pressed
```

```
IState = vntRet(1) ' Current state of the button
```

5.2.30.5. CaoRobot::Execute("ClearMechaButtonState") command

This command clears the number of times a button on the arm of COBOTTA was pressed. Also, the number of times the button was pressed will be cleared when turning off COBOTTA.

Format ClearMechaButtonState < IBtnType >

```
< IBtnType >      : Button type to clear the times (VT_I4)
                   0 : Function button
                   1 : Gripper plus button
                   2 : Gripper minus button
Retrun value      : None
```

Example

```
caoRob.Execute("ClearMechaButtonState", 0) ' Specify the function button and clear it.
```

5.2.31. CaoTask::AddVariable method

The argument of the AddVariable method of the CaoTask class specifies the system variable name.

Refer to Table 5-18 for the list of implemented system variables.

5.2.32. CaoTask::get_VariableNames property

Get a list of variable names and system variable names that can be specified by the AddVariable method.

5.2.33. CaoTask::Start method

Run the PAC program that supports the object.

The following shows the argument specifications of Start.

Syntax Start <lMode:LONG>, <bstrOpt:BSTR>

```
lMode      : [in] Start mode 1: One cycle execution, 2: Continuous execution, 3:
              Step forward
bstrOpt    : [in] Option (not used)
```

5.2.34. CaoTask::Stop method

Stop the PAC program that supports the object.

The following shows the argument specifications of Stop.

Syntax Stop <IMode:LONG>, <bstrOpt:BSTR>

IMode : [in] Stop mode 0: Default stop, 1: Instant stop, 2: Step stop, 3: Cycle stop, 4: Initialized stop

bstrOpt : [in] Option (not used)

"0: default stop" is the same as "1: Instant stop".

5.2.35. CaoTask::Execute method

Execute the command.

The arguments of the Execute method specify a command as a BSTR and a parameter as a VARIANT array.

Syntax [<vntRet:VARIANT> =] Execute(<bstrCmd:BSTR > [,<vntParam:VARIANT>])

bstrCmd : [in] Command name

vntParam : [in] Parameter

vntRet [out] Return value

If a method not defined in this class is called using the runtime binding function, the Execute method is automatically called according to the following specifications:

```
vntRet = Obj.CommandName( Param1, Param2, ... )
```

↓

```
vntRet = Obj.Execute("CommandName", Array(Param1, Param2, ... ) )
```

1. The command name is passed as a BSTR string to the first argument.
2. All the parameters are passed as a VARIANT array to the second argument.

Example

```
-----
Dim vRes As Variant
Dim caoTsk As CaoTask

Set caoTsk = caoCtrl.AddTask("pro1")
vRes = caoTsk.Execute("GetStatus") ' Get task status
-----
```

The list shows available commands.

Table 5-12 Command list of CaoTask::Execute

Category	Command name	Function
Task status		

	GetStatus	Get the task status.	P.172
Priority			
	GetThreadPriority	Get the priority.	P.172
	SetThreadPriority	Set the priority.	P.172

5.2.35.1. CaoTask::Execute("GetStatus") command

Get the status of a task.

Syntax GetStatus()

Argument	:	None
Return value	:	Status (VT_I4)
		0:TASK_NON_EXISTENT, Task is not exist.
		1:TASK_SUSPEND, Hold-stopped
		2:TASK_READY, Ready
		3:TASK_RUN, Running
		4:TASK_STEPSTOP, Step-stopped

Example

```
-----
Dim IStatus As Long
IStatus = caoTsk.Execute("GetStatus" )
-----
```

5.2.35.2. CaoTask::Execute("GetThreadPriority") command

Get the execution priority of a task.

Syntax GetThreadPriority()

Argument	:	None
Return value	:	Priority (VT_I4)
		2:THREAD_PRIORITY_HIGHEST
		1:THREAD_PRIORITY_ABOVE_NORMAL
		0:THREAD_PRIORITY_NORMAL
		-1:THREAD_PRIORITY_BELOW_NORMAL
		-2:THREAD_PRIORITY_LOWEST

5.2.35.3. CaoTask::Execute("SetThreadPriority") command

Set the execution priority of a task.

Syntax SetThreadPriority([<IPriority>])

<IPriority>	:	Priority (VT_I4)
-------------	---	------------------

2:THREAD_PRIORITY_HIGHEST
 1:THREAD_PRIORITY_ABOVE_NORMAL
 0:THREAD_PRIORITY_NORMAL
 -1:THREAD_PRIORITY_BELOW_NORMAL
 -2:THREAD_PRIORITY_LOWEST

If the argument is omitted, 0 is assumed to be specified.

Return value : None

5.2.36. CaoVariable::get_Value property

Get values of the variable corresponding to the object.

For the details about the variable implementation status and data type, refer to "5.3 Variable list".

5.2.37. CaoVariable::put_Value property

Set the value of the variable corresponding to the object.

For the details about the variable implementation status and data type, refer to "5.3 Variable list".

5.2.38. CaoExtension::Execute method

Execute the command of an extended function.

The arguments of the Execute method specify a command as a BSTR and a parameter as a VARIANT array.

Syntax [`<vntRet:VARIANT> =] Execute(<bstrCmd:BSTR > [, <vntParam:VARIANT>])`

<code>bstrCmd</code>	:	[in]	Command name
<code>vntParam</code>	:	[in]	Parameter
<code>vntRet</code>	:	[out]	Return value

If a method not defined in this class is called using the runtime binding function, the Execute method is automatically called according to the following specifications:

```
vntRet = Obj.CommandName( Param1, Param2, ... )
```

↓

```
vntRet = Obj.Execute( "CommandName", Array(Param1, Param2, ... ) )
```

1. The command name is passed as a BSTR string to the first argument.
2. All the parameters are passed as a VARIANT array to the second argument.

Example Hand object operation

```
Dim caoExt As CaoExtension

Set caoExt = caoCtrl.AddExtension( "Hand0" )
CaoExt.Execute "Motor", true      'Electric gripper motor
caoExt.Execute "Org"              ' Origin return
```

```
caoExt.Execute "Chuck", 0      ' Execute chuck operation
caoExt.Execute "UnChuck", 1   ' Execute unchuck operation
```

Example K3Hand object operation

```
Dim caoExt As CaoExtension

Set caoExt = caoCtrl.AddExtension( "K3Hand" )
CaoExt.Motor true      ' Servo ON
caoExt.Speed 50       ' Set Speed

caoExt.MoveJ, "J(0,10,0,0)"      ' Move Servo0 and Servo2 and Servo3 to 0deg, Servo1 to 10deg
```

The list shows currently available commands.

Table 5-13 CaoExtension::Execute method command list

Category	Command name	Function	
Hand object			
	Chuck	Execute chuck operation.	P.175
	UnChuck	Execute unchuck operation.	P.176
	Motor	Turn ON/OFF the motor power.	P.176
	Org	Execute origin return.	P.176
	MoveP	Execute point operation.	P.177
	MoveA	Execute absolute position movement.	P.177
	MoveR	Execute relative position movement.	P.178
	MoveAH	Execute hold operation in acceleration/deceleration absolute position movement.	P.178
	MoveRH	Execute hold operation in acceleration/deceleration relative position movement.	P.178
	MoveH	Execute hold operation in constant speed movement.	P.179
	MoveZH	Execute hold operation in zone-specific constant speed movement.	P.179
	Stop	Stop the operation.	P.180

CurPos	Get the current position.	P.180
GetPoint	Get the point data element.	P.181
get_EmgState	Get the emergency stop input status.	P.181
get_ZonState	Get the ZON signal status.	P.182
get_OrgState	Get the origin return status.	P.182
get_HoldState	Get the hold status.	P.182
get_InposState	Get the INPOS status.	P.183
get_Error	Get the electric gripper error information.	P.183
get_BusyState	Get the operation status.	P.184
get_MotorState	Get the motor power status.	P.184

K3Hand**Object**

Motor	Turn ON/OFF the motor power.	P.184
Speed	Set moving speed	P.185
MoveJ	Execute absolute position movement.	P.185
BusyState	Get the operation status.	P.186
CurPos	Get the current position.	P.186
DestPos	Get the target position.	P.186
GetParam	Get the parameter	P.187
SetParam	Set the parameter	P.187
GetPoint	Get the point data element.	P.188
SetPoint	Set the point data element.	P.188
SavePoint	Save the point data element.	P.188

5.2.38.1. Hand object - CaoExtension::Execute("Chuck") command

Execute chuck operation according to the specified point data.

Syntax Chuck(<No>)

Argument : No [in] Point number (0 to 31) [VT_I4]
Return value : None

Execute the work hold operation according to the settings in the specified point data.

The hold operation must be set in the point data in advance.

The command cannot be executed if the operation status is busy (unless get_BusyState is 0).

Example

```
caoExt.Execute "Chuck", 0
```

5.2.38.2. Hand object - CaoExtension::Execute("UnChuck") command

Execute unchuck operation according to the specified point data.

Syntax UnChuck(<No>)

Argument	:	No [in] Point number (0 to 31) [VT_I4]
Return value	:	None

Move the electric gripper from the hold status to the preset position according to the settings in the specified point data.

The movement operation must be set in the point data in advance.

The command cannot be executed if the operation status is busy (unless get_BusyState is 0).

Example

```
caoExt.Execute "UnChuck", 1
```

5.2.38.3. Hand object - CaoExtension::Execute("Motor") command

Turn ON/OFF the motor power.

Syntax Motor (<State>)

Argument	:	State [in] Motor status [VT_I4]
		0: Motor OFF
		Other than 0: Motor ON
Return value	:	None

Turn ON or OFF the motor of the electric gripper. While the electric gripper is in an emergency stop status, executing the motor-ON command does not turn ON the motor. While the electric gripper is already in motor-ON status, executing the motor-ON command has no effect and the electric gripper's motor remains ON.

The command cannot be executed if the operation status is busy (unless get_BusyState is 0).

Example

```
caoExt.Execute "Motor", 1
```

5.2.38.4. Hand object - CaoExtension::Execute("Org") command

Execute origin return.

Syntax Org()

Argument : None
Return value : None

Execute origin return.

This command must be executed at least once after the electric gripper power is turned ON. If an error occurs, origin return must also be executed after the error is reset.

Before origin return is completed, executing an operation command of the electric gripper causes an error.

The command cannot be executed if the operation status is busy (unless get_BusyState is 0).

Example

```
-----
caoExt.Execute "Org"
-----
```

5.2.38.5. Hand object - CaoExtension::Execute("MoveP") command

Execute point operation.

Syntax MoveP (<No>)

Argument : No [in] Point number (0 to 31) [VT_I4]
Return value : None

Execute the end-effector operation according to the settings in the specified point data.

Point data must be set before this operation.

The command cannot be executed if the operation status is busy (unless get_BusyState is 0).

Example

```
-----
caoExt.Execute "MoveP" , 1
-----
```

5.2.38.6. Hand object - CaoExtension::Execute("MoveA") command

Execute absolute position movement operation.

Syntax MoveA (<Pos>, <Speed>)

Argument : Pos [in] Position (-999.90 to 999.90 [mm]) [VT_R4]
: Speed [in] Speed (20 to 100[%]) [VT_I4]
Return value : None

Execute the absolute position movement operation of the end-effector to the specified position at the specified speed.

The command cannot be executed if the operation status is busy (unless get_BusyState is 0).

Example

```
caoExt.Execute "MoveA" , Array(5.00, 20)
```

5.2.38.7. Hand object - CaoExtension::Execute("MoveR") command

Execute absolute position movement operation.

Syntax MoveR (<Pos>, <Speed>)

Argument	:	Pos	[in] Position (-999.90 to 999.90 [mm])	[VT_R4]
	:	Speed	[in] Speed (20 to 100[%])	[VT_I4]
Return value	:	None		

Execute the relative position movement operation of the end-effector to the specified position at the specified speed.

The command cannot be executed if the operation status is busy (unless get_BusyState is 0).

Example

```
caoExt.Execute "MoveR" , Array(-3.00, 100)
```

5.2.38.8. Hand object - CaoExtension::Execute("MoveAH") command

Execute the absolute position hold operation with acceleration/deceleration.

Syntax MoveAH (<Pos>, <Speed>, <Force>)

Argument	:	Pos	[in] Position (-999.90 to 999.90 [mm])	[VT_R4]
	:	Speed	[in] Speed (20 to 100[%])	[VT_I4]
	:	Force	[in] Hold force (30 to 100[%])	[VT_I4]
Return value	:	None		

Execute the absolute position movement and hold operation of the electric gripper at the specified position and speed with the specified hold force.

The command cannot be executed if the operation status is busy (unless get_BusyState is 0).

Example

```
caoExt.Execute "MoveAH" , Array(2.50, 100, 100)
```

5.2.38.9. Hand object - CaoExtension::Execute("MoveRH") command

Execute the relative position hold operation with acceleration/deceleration.

Syntax MoveRH (<Pos>, <Speed>, <Force>)

Argument	:	Pos	[in] Position (-999.90 to 999.90 [mm])	[VT_R4]
	:	Speed	[in] Speed (20 to 100[%])	[VT_I4]
	:	Force	[in] Hold force (30 to 100[%])	[VT_I4]
Return value	:	None		

Execute the relative position movement and hold operation of the electric gripper at the specified position and speed with the specified hold force.

The command cannot be executed if the operation status is busy (unless get_BusyState is 0).

Example

```
-----
caoExt.Execute "MoveRH" , Array(2.50, 100, 100)
-----
```

5.2.38.10. Hand object - CaoExtension::Execute("MoveH") command

Execute hold operation in constant speed movement.

Syntax MoveH (<Speed>, <Force>, <Direct>)

Argument	:	Speed	[in] Speed (20 to 50[%])	[VT_I4]
	:	Force	[in] Hold force (30 to 100[%])	[VT_I4]
	:	Direct	[in] Movement direction	[VT_I4]
			0: Open direction	
			Other than 0: Close direction	
Return value	:	None		

Execute the constant speed movement and hold operation of the electric gripper at the specified speed in the specified movement direction with the specified hold force.

The command cannot be executed if the operation status is busy (unless get_BusyState is 0).

Example

```
-----
caoExt.Execute "MoveH" , Array(50, 100, 1)
-----
```

5.2.38.11. Hand object - CaoExtension::Execute("MoveZH") command

Execute hold operation in zone-specified constant speed movement.

Syntax MoveZH (<Speed>, <Force>, <Direct>)

Argument	:	ZON1	[in] ZON range 1 (-999.90 to 999.90 [mm])	[VT_R4]
	:	ZON2	[in] ZON range 2 (-999.90 to 999.90 [mm])	[VT_R4]

	:	Speed [in] Speed (20 to 50[%])	[VT_I4]
	:	Force [in] Hold force (30 to 100[%])	[VT_I4]
	:	Direct [in] Movement direction	[VT_I4]
		0: Open direction	
		Other than 0: Close direction	
Return value	:	None	

Execute the constant speed movement and hold operation of the electric gripper in the specified ZON range at the specified speed in the specified movement direction with the specified hold force.

Once the end-effector is within the ZON range 1 and ZON range 2, `get_ZonState` becomes an in-range status (other than 0).

The command cannot be executed if the operation status is busy (unless `get_BusyState` is 0).

Example

```
-----
caoExt.Execute "MoveZH" , Array(1.00, 4.00, 50, 100, 1)
-----
```

5.2.38.12. Hand object - `CaoExtension::Execute("Stop")` command

Stop the operation.

Syntax `Stop ()`

Argument	:	None
Return value	:	None

While the electric gripper is running, execute this command to stop the operation immediately.

Example

```
-----
caoExt.Execute "Stop"
-----
```

5.2.38.13. Hand object - `CaoExtension::Execute("CurPos")` command

Return the current position.

Syntax `CurPos ()`

Argument	:	None
Return value	:	[out] Current position [mm] [VT_R4]

Return the current position [mm] of the electric gripper.

Depending on the timing, it takes 10 ms at the maximum.

Example

```
Dim handPos as Single
handPos = caoExt.Execute( "CurPos" )
```

5.2.38.14. Hand object - CaoExtension::Execute("GetPoint") command

Return the point data elements.

Syntax GetPoint (<No>, <Index>)

Argument	:	No	[in] Point number (0 to 31)	[VT_I4]
	:	Index	[in] Point data element (0 to 5)	[VT_I4]
Return value	:	[out]	Value of the specified element of the specified point data	
			0: Operation mode	
		1:	Distance [mm]	[VT_R4]
		2:	Speed [mm]	[VT_I4]
		3:	Hold force [%]	[VT_I4]
		4:	ZON range 1 [mm]	[VT_R4]
		5:	ZON range 2 [mm]	[VT_R4]

Return the value of the specified element of the specified point data.

Example

```
Dim Speed as Long
Speed = caoExt.Execute( "GetPoint", Array(0, 2) )
```

5.2.38.15. Hand object - CaoExtension::Execute("get_EmgState") command

Inform the emergency stop signal input status.

Syntax get_EmgState ()

Argument	:	None
Return value	:	Emergency stop signal input status [VT_I4]
		0: Emergency stop status
		Other than 0: Emergency stop cleared status
		(The emergency stop input is short-circuited.)

Return the emergency stop status of the electric gripper.

Example

```
Dim State as Long
State = caoExt.Execute( "get_EmgState" )
```

5.2.38.16. Hand object - CaoExtension::Execute("get_ZonState") command

Inform the status whether the electric gripper is positioned within the set range.

Syntax get_EmgState ()

Argument	:	None	
Return value	:	ZON status	[VT_I4]
		0: Positioned out of the range specification	
		Other than 0: Positioned between the range specifications 1 and 2	

Return the status whether the electric gripper is positioned within the set range.

Example

```
Dim State as Long
State = caoExt.Execute( "get_ZonState")
```

5.2.38.17. Hand object - CaoExtension::Execute("get_OrgState") command

Inform the origin return status.

Syntax get_OrgState ()

Argument	:	None	
Return value	:	Origin return status	[VT_I4]
		0: Origin return is not completed	
		Other than 0: Origin return is completed	

Inform the origin return status.

Example

```
Dim State as Long
State = caoExt.Execute( "get_OrgState")
```

5.2.38.18. Hand object - CaoExtension::Execute("get_HoldState") command

Inform the hold status of the electric gripper.

Syntax get_HoldState ()

Argument	:	None	
Return value	:	Hold status	[VT_I4]
		0: Not holding	

Other than 0: Holding the work with the specified hold force

Return the hold status of the electric gripper.

Example

```
-----
Dim State as Long
State = caoExt.Execute( "get_HoldState")
-----
```

5.2.38.19. Hand object - CaoExtension::Execute("get_InposState") command

Inform whether the end-effector is in the target position (INPOS status).

Syntax get_InposState ()

Argument	:	None	
Return value	:	INPOS status	[VT_I4]
		0: Out of the target position or currently moving	
		Other than 0: Within the target position range after origin return or positioning operation	

Return whether the end-effector is in the target position (INPOS status).

The target position range is determined by the "positioning completion distance" parameter.

Example

```
-----
Dim State as Long
State = caoExt.Execute( "get_InposState")
-----
```

5.2.38.20. Hand object - CaoExtension::Execute("get_Error") command

Inform the error status of the electric gripper.

Syntax get_Error ()

Argument	:	None	
Return value	:	Error code (decimal format data)	[VT_I4]
		0: Normal status	
		Other than 0: An error occurred. The value represents an error code.	

Return the error status of the electric gripper.

Example

```
-----
Dim State as Long
State = caoExt.Execute( "get_Error")
-----
```

5.2.38.21. Hand object - CaoExtension::Execute("get_BusyState") command

Inform the operation status.

Syntax get_BusyState ()

Argument	:	None	
Return value	:	Operation status	[VT_I4]

0: An operation command can be received.
Other than 0: Running. An operation command came in and was received.

Return the operation status of the electric gripper.

Example

```
Dim State as Long
State = caoExt.Execute("get_BusyState")
```

5.2.38.22. Hand object - CaoExtension::Execute("get_MotorState") command

Inform the motor power status.

Syntax get_MotorState ()

Argument	:	None	
Return value	:	Motor power status	[VT_I4]

0: Motor power OFF
Other than 0: Motor power ON

Return the motor power status of the electric gripper.

Example

```
Dim State as Long
State = caoExt.Execute("get_MotorState")
```

5.2.38.23. K3Hand object - CaoExtension::Execute("Motor") command

Turn ON/OFF the motor power. This command is only for K3Hand.

Syntax Motor (<vbEnable>)

vbEnable	:	[in] Motor status [VT_BOOL]
----------	---	-----------------------------

True: Motor ON

Return value : None
False: Motor OFF

Example

```
-----
caoExt.Motor True
-----
```

5.2.38.24. K3Hand object - CaoExtension::Execute("Speed") command

Set the moving speed. This command is only for K3Hand.

Syntax Speed (<sngSpeed>)

sngSpeed : [in] Speed [%](VT_R4)

Example

```
-----
caoExt.Speed 100
-----
```

5.2.38.25. K3Hand object - CaoExtension::Execute("MoveJ") command

Execute movement operation. This command is only for K3Hand.

Syntax MoveJ (<lPointNo> or <bstrEachPose> or <bstrAllPose>)

lPointNo : [in] Point number [0 to 99](VT_I4)

bstrEachPose : [in] Target pose of each servo[deg] (VT_BSTR)

-Example:

```
MoveJ "(1, 50), (4, 30)"
```

' Moving Servo1 to 50deg and Servo4 to 30deg

bstrAllPose : [in] Target pose of all servo[deg] (VT_BSTR)

-Example:

```
MoveJ "J(0, 50, 0, 0, 30, 0, 0, 0)"
```

' Moving Servo1 to 50deg and Servo4 to 30deg,
and other Servo to 0deg

Return value : None

Example

```
-----
caoExt.MoveJ 1
caoExt.MoveJ "(1, 50), (4, 30)"
caoExt.MoveJ "J(0, 50, 0, 0, 30, 0, 0, 0)"
-----
```

5.2.38.26. K3Hand object - CaoExtension::Execute("BusyState") command

Inform the operation status. This command is only for K3Hand.

Syntax BusyState ()

Return value : Operation status [VT_BOOL]
 True: Running. An operation command came in and was received.
 False: An operation command can be received.

Example

```
Dim State as Boolean
State = caoExt.BusyState
```

5.2.38.27. K3Hand object - CaoExtension::Execute("CurPos") command

Return current position of all servo. This command is only for K3Hand.

Syntax CurPos ()

Return value : Current position [VT_R8 | VT_ARRAY]
 Length of array is equal to total number of servo.

Example

```
Dim vntPos as Variant
vntPos = caoExt.CurPos

Debug.Print vntPos(0) 'Display the servo0 current position
```

5.2.38.28. K3Hand object - CaoExtension::Execute("DestPos") command

Return target position of all servo. This command is only for K3Hand.

Syntax DestPos ()

Return value : Target position [VT_R8 | VT_ARRAY]
 Length of array is equal to total number of servo.

Example

```
Dim vntPos as Variant
vntPos = caoExt.DestPos

Debug.Print vntPos(0) 'Display the servo0 target position
```

5.2.38.29. K3Hand object - CaoExtension::Execute("GetParam") command

Return the parameter of K3Hand. This command is only for K3Hand.

Syntax GetParam (<IIndex>)

IIndex : [in] Parameter index(VT_I4)
See following table for details.
Return value : Parameter value [VT_VARIANT]

Example

```
Dim vntRet as Variant
vntRet = caoExt.GetParam(1)
```

5.2.38.30. K3Hand object - CaoExtension::Execute("SetParam") command

Set the parameter of K3Hand. This command is only for K3Hand.

Syntax SetParam (<IIndex>, <vntParam>)

IIndex : [in] Parameter index(VT_I4)
See following table for details.
vntParam : [in] Parameter value
Return value : None

Example

```
caoExt.SetParam 1, 10
```

The parameters that can be operated by Set/GetParam command are shown in the following table.

Table 5-14 K3Hand parameters

Index	Name	Type	Explanation	Attribute	
				Get	Set
0	MotorState	VT_I4	Get/Set the motor power status.(Bit Array) 0bit:Servo0 power 1bit:Servo1 power...	<input type="radio"/>	<input type="radio"/>
1	BusyState	VT_BOOL	Get the operation status.	<input type="radio"/>	
2	Speed	VT_R4	Get/Set the speed of movemant.	<input type="radio"/>	<input type="radio"/>

3	ServoCount	VT_I4	Get servo count.	○	
4	MovableRange	VT_VARIANT VT_ARRAY	Get movable range for each servo. Positive direction limit: VT_R4 VT_ARRAY Negative direction limit: VT_R4 VT_ARRAY	○	
5	HandType	VT_I4	Get hand type data.	○	
6	HardRevision	VT_I4	Get hard revision data.	○	
7	ServoCurrent	VT_R4 VT_ARRAY	Get each servo current.	○	
8	BusVoltage	VT_R4	Get bus voltage.	○	
9	BusCurrent	VT_R4	Get bus current.	○	

5.2.38.31. K3Hand object - CaoExtension::Execute("GetPoint") command

Return the point data elements. This command is only for K3Hand.

Syntax GetPoint (<IPointNo>)

IPointNo : [in] Point number [0 to 99] (VT_I4)
Return value : [out] Value of the specified point(VT_R8 | VT_ARRAY)

Example

```
-----
Dim vntPointData as Variant
vntPointData = caoExt.GetPoint(1)
-----
```

5.2.38.32. K3Hand object - CaoExtension::Execute("SetPoint") command

Set the point data elements. This command is only for K3Hand.

Syntax SetPoint (<IPointNo>, <vntPointData>)

IPointNo : [in] Point number [0 to 99] (VT_I4)
vntPointData : [in] Array of point data (VT_R8 | VT_ARRAY)
Return value : None

Example

```
-----
caoExt.SetPoint 1, Array(0,0,0,0,0,0,0,0)
-----
```

5.2.38.33. K3Hand object - CaoExtension::Execute("SavePoint") command

Save the point data elements. This command is only for K3Hand.

Syntax SavePoint (<IPointNo>)

IPointNo : [in] Point number [0 to 99] (VT_I4)
 Return value : None

Example

 caoExt.SaavePoint 1

5.3. Variable list

5.3.1. Controller class

Table 5-15 Controller class user variable list

Variable identifier	Data type	Explanation	Attribute	
			get	put
I	VT_I4	I type variable. The variable number is specified after the variable name.	√	√
F	VT_R4	F type variable. The variable number is specified after the variable name.	√	√
D	VT_R8	D type variable. The variable number is specified after the variable name.	√	√
V	VT_ARRAY VT_R4	V type variable. The variable number is specified after the variable name. The data type has three elements.	√	√
P	VT_ARRAY VT_R4	P type variable. The variable number is specified after the variable name. The data type has seven elements.	√	√
J	VT_ARRAY VT_R4	J type variable. The variable number is specified after the variable name. The data type has eight elements.	√	√
T	VT_ARRAY VT_R4	T type variable. The variable number is specified after the variable name. The data type has ten elements.	√	√
S	VT_BSTR	S type variable. The variable number is specified after the variable name.	√	√
IARRAY	VT_ARRAY VT_I4	Handles an I type variable as an I4 type array. "IARRAY*" (* is a value) represents a variable name. A variable is defined by specifying the start number and the array size. After that, it is accessed as an array variable. See the example below:	√	√

FARRAY	VT_ARRAY VT_R4	Handles an F type variable as a R4 type array. "FARRAY*" (* is a value) represents a variable name. A variable is defined by specifying the start number and the array size. After that, it is accessed as an array variable. See the example below:	√	√
DARRAY	VT_ARRAY VT_R8	Handles a D type variable as a R8 type array. "DARRAY*" (* is a value) represents a variable name. A variable is defined by specifying the start number and the array size. After that, it is accessed as an array variable. See the example below:	√	√
VARRAY	(VT_ARRAY VT_R4)* array size	Handles a V type variable as an array. V type variable is specified by a R4 type array. "VARRAY*" (* is a value) represents a variable name. A variable is defined by specifying the start number and the array size. After that, it is accessed as an array variable. See the example below:	√	√
PARRAY	(VT_ARRAY VT_R4)* array size	Handles a P type variable as an array. P type variable is specified by a R4 type array. "PARRAY*" (* is a value) represents a variable name. A variable is defined by specifying the start number and the array size. After that, it is accessed as an array variable. See the example below:	√	√
JARRAY	(VT_ARRAY VT_R4)* array size	Handles a J type variable as an array. J type variable is specified by a R4 type array. "JARRAY*" (* is a value) represents a variable name. A variable is defined by specifying the start number and the array size. After that, it is accessed as an array variable. See the example below:	√	√
TARRAY	(VT_ARRAY VT_R4)* array size	Handles a T type variable as an array. T type variable is specified by a R4 type array. "TARRAY*" (* is a value) represents a variable name. A variable is defined by specifying the start number and the array size. After that, it is accessed as an array variable. See the example below:	√	√
SARRAY	VT_ARRAY VT_BSTR	Handles an S type variable as a BSTR type array. "SARRAY*" (* is a value) represents a variable name. A variable is defined by specifying the start number and the array size. After that, it is accessed as an array variable. See the example below:	√	√
IO	VT_BOOL	IO type variable. The variable number is specified after the variable name.	√	√
IOB	VT_I1	IO type variable. The variable number is specified after the variable name.	√	√
IOW	VT_I2	IO type variable. The variable number is specified after the variable name.	√	√
IOD	VT_I4	IO type variable. The variable number is specified after the variable name.	√	√

IOF	VT_R4	IO type variable. The variable number is specified after the variable name.	√	√
IOARRAY	VT_ARRAY VT_BOOL	Handles an IO as a BOOL type array. "IOARRAY*" (* is a value) represents a variable name. A variable is defined by specifying the start number and the array size. After that, it is accessed as an array variable. See the example below:	√	√
IOBARRAY	VT_ARRAY VT_I1	Handles an IO as an I1 type array. "IOBARRAY*" (* is a value) represents a variable name. A variable is defined by specifying the start number and the array size. After that, it is accessed as an array variable. See the example below:	√	√
IOWARRAY	VT_ARRAY VT_I2	Handles an IO as an I2 type array. "IOWARRAY*" (* is a value) represents a variable name. A variable is defined by specifying the start number and the array size. After that, it is accessed as an array variable. See the example below:	√	√
IODARRAY	VT_ARRAY VT_I4	Handles an IO as an I4 type array. "IODARRAY*" (* is a value) represents a variable name. A variable is defined by specifying the start number and the array size. After that, it is accessed as an array variable. See the example below:	√	√
IOFARRAY	VT_ARRAY VT_R4	Handles an IO as an R4 type array. "IOFARRAY*" (* is a value) represents a variable name. A variable is defined by specifying the start number and the array size. After that, it is accessed as an array variable. See the example below:	√	√

Example

IARRAY

'A variable which is handled as the array of three elements from the 0th to the second element of the variable definition of I type variable

```
Dim IArray0 as CaoVariable
```

```
Set IArray0 = caoCtrl.AddVariable("IArray0", "StartNo = 0, ArraySize = 3")
```

```
IArray0 = Array(1,2,3) I0=1, I1=2, and I2=3.
```

PARRAY

'A variable which is handled as the array of two elements from the first to the second element of the variable definition of P type variable.

Dim PArray0 as CaoVariable

Set PArray0 = caoCtrl.AddVariable("PArray0", "StartNo = 1, ArraySize = 2")

PArray0 = Array(Array(1,2,3,4,5,6,-1), Array(1,2,3,4,5,6,-1))

'IOARRAY

' Variable definition VT_BOOL type, starting from IO number 128, array of three elements.

Dim IOArray0 As CaoVariable

Set IOArray0 = g_caoCtrl.AddVariable("IOArray0", "StartIoNo = 128, ArraySize = 3")

' Value setting

IOArray0 = Array(True, False, True)

' Value obtainment

vntVal = IOArray0

'IOFARRAY

' Variable definition VT_R4 type, starting from IO number 160, array of four elements.

Dim IOFArray0 As CaoVariable

Set IOFArray0 = g_caoCtrl.AddVariable("IOFArray0", "StartIoNo = 160, ArraySize = 4")

'値設定

IOFArray0 = Array(123.45, 234.56, 0.88, 345.67)

'値取得

vntVal = IOFArray0

Table 5-16 Controller class system variable list

Variable identifier	Data type	Explanation	Attribute	
			get	put
@VAR_I_LEN	VT_I4	Size of global I type variable	√	√
@VAR_F_LEN	VT_I4	Size of global F type variable	√	√
@VAR_D_LEN	VT_I4	Size of global D type variable	√	√
@VAR_V_LEN	VT_I4	Size of global V type variable	√	√
@VAR_J_LEN	VT_I4	Size of global J type variable	√	√
@VAR_P_LEN	VT_I4	Size of global P type variable	√	√

@VAR_T_LEN	VT_I4	Size of global T type variable	√	√
@VAR_S_LEN	VT_I4	Size of global S type variable	√	√
@VAR_IO_LEN	VT_I4	I/O point number (number of bits)	√	-
@MODE	VT_I4	1: manual, 2: teach check, 3: auto	√	√ ⁵
@LOCK	VT_BOOL	true: Machine lock ON, false: Machine lock OFF	√	√
@TIME	VT_I4	Actual time elapsed since machine activation (msec)	√	-
@CURRENT_TIME	VT_DATE	Current time	√	-
@BUSY_STATUS	VT_BOOL	true = Program running, false = Program stopped	√	-
@TSR_BUSY_STATUS	VT_BOOL	true = Supervisory tasks running, false = Supervisory tasks stopped	√	-
@NORMAL_STATUS	VT_BOOL	true = Normal, false = Abnormal (An error has occurred.)	√	-
@ERROR_CODE	VT_I4	Code of an error that has occurred as a decimal number. 0 is returned if no error has occurred. Setting 0 clears the error.	√	√
@ERROR_CODE_HEX	VT_BSTR	Code of an error that has occurred as a hexadecimal character string. "00000000" is returned if no error has occurred.	√	-
@ERROR_DESCRIPTION	VT_BSTR	Description of an error that has occurred	√	-
@EMERGENCY_STOP	VT_BOOL	true = Emergency stop is active. false = Emergency stop is not active.	√	-
@DEADMAN_SW	VT_BOOL	Deadman status	√	-
@AUTO_ENABLE	VT_BOOL	Auto enable status	√	-
@MAKER_NAME	VT_BSTR	"DENSO CORPORATION"	√	-
@TYPE	VT_BSTR	"RC8 Controller"	√	-
@VERSION	VT_BSTR	Controller's version	√	-

⁵ This command is available only for VRC (Virtual Robot Controller).

@SERIAL_NO	VT_BSTR	Controller's serial number	√	-
@PROTECTIVE_STOP	VT_BOOL	Protective stop	√	-
@IO_ALLOC_MODE	VT_I4	I/O Allocation Mode 0: MiniI/O Dedicated Mode 1: Standard Mode 2: RC3 Compatible Mode 3: All user I/O Mode	√	-

5.3.2. Robot class

Table 5-17 Robot class system variable list

Variable identifier	Data type	Explanation	Attribute	
			get	put
@CURRENT_POSITION	VT_ARRAY VT_R8	Current robot position. The unit is arbitrary. P type variable.	√	-
@CURRENT_ANGLE	VT_ARRAY VT_R8	Current robot position (each axis value). The unit is arbitrary. J type variable	√	-
@SERVO_ON	VT_BOOL	true = Servo ON, false = Servo OFF	√	√
@BUSY_STATUS	VT_BOOL	true = Arm moving, false = Arm stopped	√	-
@TYPE_NAME	VT_BSTR	Robot type name	√	-
@TYPE	VT_I4	Robot type data	√	-
@CURRENT_TRANS	VT_ARRAY VT_R8	Current robot position expressed in T type	√	-
@CURRENT_TOOL	VT_I4	Currently used tool number	√	√
@CURRENT_WORK	VT_I4	Currently used work number	√	√
@SPEED	VT_R4	Internal speed	√	√
@ACCEL	VT_R4	Internal acceleration	√	√
@DECEL	VT_R4	Internal deceleration	√	√

@JSPEED	VT_R4	Internal joint speed	√	√
@JACCEL	VT_R4	Internal joint acceleration	√	√
@JDECEL	VT_R4	Internal joint deceleration	√	√
@EXTSPEED	VT_R4	External speed	√	√
@EXTACCEL	VT_R4	External acceleration	√	√
@EXTDECEL	VT_R4	External deceleration	√	√
@HIGH_CURRENT_POSITION	VT_ARRAY VT_R8	Current robot position. P type variable. Function specification: When the controller is not in machine-lock mode, the current encoder value is returned.	√	-
@HIGH_CURRENT_ANGLE	VT_ARRAY VT_R8	Current robot position (each axis value). J type variable. For function specification, refer to @HIGH_CURRENT_POSITION.	√	-
@HIGH_CURRENT_TRANS	VT_ARRAY VT_R8	Current robot position expressed in T type. For function specification, refer to @HIGH_CURRENT_POSITION.	√	-
@DEST_ANGLE	VT_ARRAY VT_R8	Previous motion command target position. J type variable. While the robot is stopped, the current position (command value) is returned.	√	-
@DEST_POSITION	VT_ARRAY VT_R8	Previous motion command target position. P type variable. While the robot is stopped, the current position (command value) is returned.	√	-
@DEST_TRANS	VT_ARRAY VT_R8	Previous motion command target position. T type variable. While the robot is stopped, the current position (command value) is returned.	√	-

@STATE	VT_I4	Motion status of the robot. 0: Motion completed 1: Continue-stopped 2: In motion (Manual) 3: In motion (Auto)	√	-
@ASP_MODE	VT_I4	Control sets of Optimal Speed Control 0: Disable 1: PTP 2: CP 3: PTP, CP	√	√
@ERROR_CODE	VT_I4	Code of an error that has occurred as a decimal number. 0 is returned if no error has occurred. Setting 0 clears the error.	√	√
@ERROR_DESCRIPTION	VT_BSTR	Description of an error that has occurred	√	-
@LOCK	VT_BOOL	true = Machine lock ON, false = Machine lock OFF	√	√
Tool*	VT_ARRAY VT_R8	Tool definition with the number represented by * X,Y,Z,RX,RY,RZ	√	√
Work*	VT_ARRAY VT_R8	Work definition with the number represented by * X,Y,Z,RX,RY,RZ,Attribute	√	√
Area*	VT_ARRAY VT_R8	Area definition with the number represented by * X,Y,Z,RX,RY,RZ,DX,DY,DZ,IO,Position,Error,Time,DRX,DRY,DRZ,Margin,Position1,Margin1,Position2,Margin2,Position3,Margin3,Position4,Margin4,Position5,Margin5,Position6,Margin6,Position7,Margin7,Position8,Margin8,Enable	√	√
Base*	VT_ARRAY VT_R8	Enter the definition of Base1 coordinate. X, Y, Z, RX, RY, RZ, Attribute For Attribute, enter 0.	√	√

5.3.3. Task class

Table 5-18 Task class system variable list

Variable identifier	Data type	Explanation	Attribute	
			get	Put

@STATUS	VT_I4	State of task 0: Task not yet generated (NON_EXISTENT) 1: Hold-stopped 2: Stopped 3: Running 4: Step-stopped	√	-
@PRIORITY	VT_I4	Priority of task. Not supported. Refer to SetThreadPriority() and GetThreadPriority().	-	-
@LINE_NO	VT_I4 VT_ARRAY	Line number and file ID of currently running task. [0] = Line number [1] = Running file ID (corresponding to CaoFile::get_ID())	√	-
@CYCLE_TIME	VT_I4	One cycle execution time of task. The unit is ms.	√	-
@START	VT_I4	Start a task. The meaning of the value is the same as the Mode argument of the CaoTask::Start method. The modes are 1: One cycle execution, 2: Continuous execution, 3: One step forward, and 4: One step backward. Unlike the Start method, the option cannot be specified.	-	√
@STOP	VT_I4	Stop a task. The meaning of the value is the same as the Mode argument of the CaoTask::Stop method. The modes are 0: Default stop, 1: Instant stop, 2: Step stop, 3: Cycle stop, and 4: Initialized stop. Unlike the Stop method, the option cannot be specified. Default stop (0) corresponds to Instant stop (1).	-	√
@ELAPSED_TIME	VT_I4	Time elapsed since task started running. The unit is ms.	√	-
@STATUS_DETAILS	VT_I4	Detailed task status information. TASK_NON_EXISTENT = 0, Task non-existent TASK_SUSPEND = 1, Hold-stopped TASK_READY = 2, Ready TASK_RUN = 3, Running TASK_STEPSTOP = 4, Step-stopped TASK_CNTSTP = 5, Continue-stopped TASK_PEND = 6, Pending TASK_DELAY = 7, Delay	√	-

5.3.4. File class

Table 5-19 File class system variable list

Variable identifier	Data type	Explanation	Attribute	
			get	Put
@CRC	VT_I4	CRC32	√	-

5.4. Event list

Receive events that notified the error or the status of the controller via OnMessage.

Table 5-20 OnMessage event list

Event	Event Number	Value		Explanation
		Data type	Value	
Occurrence of an error	3	VT_I4	Error code	Also occurs error of level 0
Emergency stop	5	VT_I4	ON:-1 OFF:0	-
Protection stop	6	VT_I4	ON:-1 OFF:0	-
Auto enable	7	VT_I4	ON:-1 OFF:0	-
Mode switching	9	VT_I4	MANUAL:1 TEACH:2 AUTO:3	-
Robot operation is completed	13	-	-	Event will fire when the robot operation command completed. Event occurs even when following robot operation of stop or completion . • When PacScript program has become "stopping" • When variable movement operation completed manually (It does not occur in the case of " paused ". After resumed from the " paused " , it will occur when motion completion.)

[Notes]

Other events of the above are not supported.

Example

```
Dim g_eng As CaoEngine
Dim WithEvents g_ctrl As CaoController
Dim IEventNo As Long
Dim vntVal As Variant

Private Sub Form_Load()
    Set g_eng = New CaoEngine
    ' Change the IP address for your controller
    Set g_ctrl = g_eng.Workspaces(0).AddController("RC8", "CaoProv.DENSO.RC8", "",
"Server=192.168.0.1")
End Sub

Private Sub Form_Unload(Cancel As Integer)
    ' Release CaoController
    g_eng.Workspaces(0).Controllers.Remove g_ctrl.Index
    Set g_ctrl = Nothing
    ' Release CaoEngine
    Set g_eng = Nothing
End Sub

Private Sub g_ctrl_OnMessage(ByVal pICaoMess As CAOLib.ICaoMessage)
    IEventNo = pICaoMess.Number
    vntVal = pICaoMess.Value
End Sub
```

Appendix A. CaoController Object Creation

Following shows how to create CaoController of ORiN.

- (1) Create variables to store objects.
- (2) Create a CaoEngine object.
- (3) Acquire or create a CaoWorkspace object.
- (4) Create a CaoController object.

Following is detailed explanation of the procedure. In this example, the language in use is Visual Basic 6.0, and objects are created with New keyword.

- (1) First, declare variables to store objects. The objects required to open a controller are CaoEngine and CaoWorkspace. Furthermore, the AddController method creates a CaoController object. Therefore, create variables for these three objects. Following is an example of declaring variables for each object type as private variables.

```
-----
Private caoEng As CaoEngine      ' Engine object
Private caoWs As CaoWorkspace    ' CaoWorkSpace object
Private caoCtrl As CaoController ' Controller object
-----
```

- (2) Next, create a CaoEngine object by using New keyword and assign it to the variable by using the Set statement.

```
-----
Set caoEng = New CaoEngine
-----
```

- (3) When a CaoEngine is created, it creates a default CaoWorkspaces and a CaoWorkspace object. To acquire the default CaoWorkspace object, use CaoWorkspaces.Item(0). Following is an example of acquiring the default CaoWorkspace object.

```
-----
Set caoWs = caoEng.CaoWorkspaces.Item(0)
-----
```

- (4) A CaoController object can be created using the AddController method of the CaoWorkspace object.

```
-----
' CaoCtrl and CaoWS are variables used to store objects.
Set CaoCtrl = caoWs.AddController("RC8","CaoProv.DENSO.RC8", " ", "Server=192.168.0.1")
-----
```

Example

```
-----  
Private caoEng As CaoEngine           ' Engine object  
Private caoWs As CaoWorkspace        ' WorkSpace object  
Private caoCtrl As CaoController     ' Controller object  
  
Set caoEng = New CaoEngine  
Set caoWS = caoEng.CaoWorkspaces.Item(0)  
Set caoCtrl = CaoWs.AddController("RC8","CaoProv.DENSO.RC8", " ", "Server=192.168.0.1")  
-----
```

Appendix B. POSEDATA Type Definition

In RC8 provider, "POSEDATA " is defined so that the pose data type and vector type data of DENSO robots can be handled by VARIANT type variables.

POSEDATA type (VARIANT)

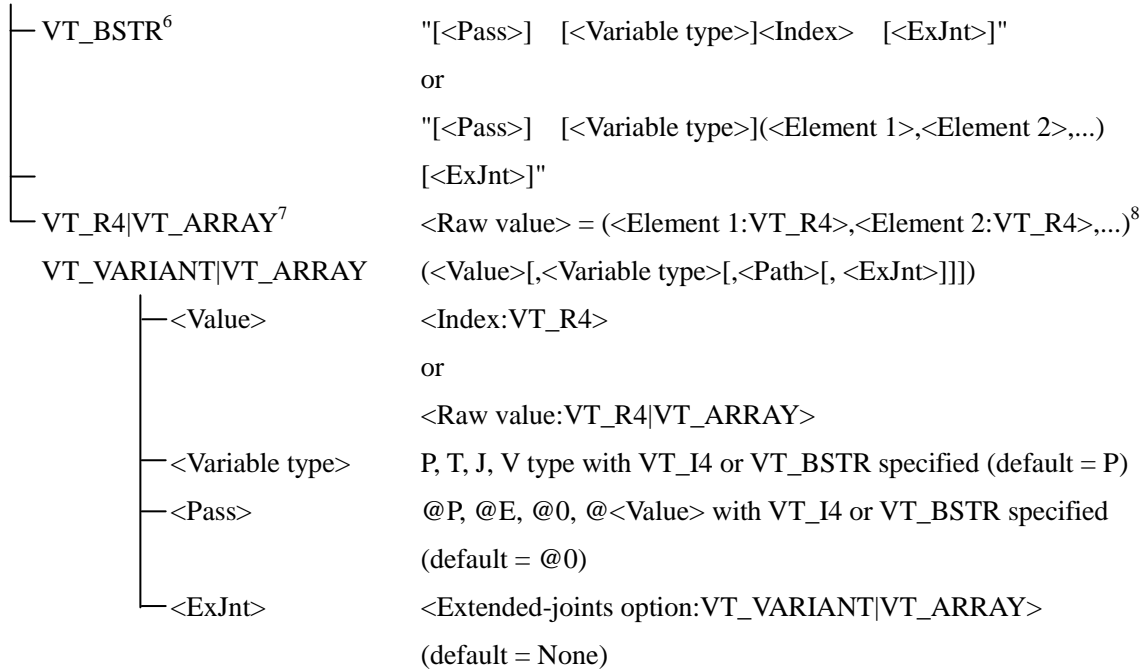

<Pass> : @P, @E, @0, @<Value>

Mark	@P	@E	@0	@<Value: n>	None
VT_BSTR	"@P"	"@E"	"@0"	"@n"	""
VT_I4	-1	-2	0	n	0

<Variable type> : P type, T type, J type, V type

Mark	P	T	J	V	None
VT_BSTR	"P"	"T"	"J"	"V"	""
VT_I4	0	1	2	3	-1

<Index> : <Value:VT_R4>

<Element n> : <Value:VT_R4>

⁶ In case of VT_BSTR, more than one POSEDATA type separated by commas can be specified.

⁷ Because <Variable type> and <Pass> cannot be specified, variable type is treated as P type and pass type is treated as @0 by default.

⁸ Because <Variable type> and <Pass> cannot be specified, variable type is treated as P type and pass type is treated as @0 by default.

<Extended-joints option> : (<EX or EXA>, (<Joint 1: VT_I4>,<Value 1: VT_R8>)[,<Joint 2>,<Value 2>]...])

Mark	EX	EXA	None
VT_BSTR	"EX"	"EXA"	""
VT_I4	1	2	0

The following formats of PacScript language can be expressed by POSEDATA type.

[<Pass start displacement>] <Pose:P,T,J type> [<ExJnt>] (C0-format)

[<Pass start displacement>] <Vector:V type> (C1-format)

[<Pass start displacement>] <Value> [<ExJnt>] (C2-format)

[<Pass start displacement>] (<Element 1>,<Element 2>,...) [<ExJnt>] (C3-format)

Appendix B.1. Examples

[<Pass start displacement>] <Pose> [<ExJnt>] (C0-format)

ex1. T200

String	"T200"
VARIANT type array (Variable type specified by string)	Array(200,"T") ⁹
VARIANT type array (Variable type specified by value)	Array(200,1)

ex2. @P J100

String	"@P J100"
VARIANT type array (Variable type and pass type specified by string)	Array(100,"J","@P")
VARIANT type array (Variable type and pass type specified by value)	Array(100,2,-1)

⁹ Array(...) is a function to return an array composed of the argument to the function. (Array function of VB6)

ex3. @E P(10.0, 10.5, 34.6, 0.0, 90.0, 0.0, -1.0)

String	"@E P(10.0, 10.5, 34.6, 0.0, 90.0, 0.0, -1.0)"
VARIANT type array (Raw value, with variable type and pass type specified by string)	Dim p(6) as Single Dim vP as Variant p(0) = 10.0 : p(1) = 10.5 : p(2) = 34.6 : p(3) = 0.0 p(4) = 90.0 : p(5) = 0.0 : p(6) = -1.0 vP = p() Array(vP,"P","@E")
VARIANT type array (Raw value, (Variable type and pass type specified by value)	Dim p(6) as Single Dim vP as Variant p(0) = 10.0 : p(1) = 10.5 : p(2) = 34.6 : p(3) = 0.0 p(4) = 90.0 : p(5) = 0.0 : p(6) = -1.0 vP = p() Array(vP, 0, -2)

ex4. @P J100 EXA((7, 30.5), (8, 90.5))

String	"@P J100 EXA((7, 30.5), (8, 90.5))"
VARIANT type array (Variable type, pass type, and extended-joints specified by string)	Array(100,"J","@P", Array("EXA",Array(7,30.5), Array(8,90.5)))
VARIANT type array (Variable type, pass type, and extended-joints specified by value)	Array(100,2,-1, Array(2, Array(7,30.5), Array(8,90.5)))

[<Pass start displacement>] <Vector:V type>	(C1-format)
---	-------------

ex1. @P V20

String	"@P V20"
VARIANT type array (Variable type and pass type specified by string)	Array(20,"V","@P")
VARIANT type array (Variable type and pass type specified by value)	Array(20,3,-1)

ex2. @E V(0.0, 125.5, 50.0)

String	"@E V(0.0, 125.5, 50.0)"
VARIANT type array (Raw value, with variable type and pass type specified by string)	Dim v(2) as Single Dim vV as Variant v(0) = 0.0 : v(1) = 125.5 : v(2) = 50.0 vV = v() Array(vV,"V","@E")

VARIANT type array (Raw value, (Variable type and pass type specified by value)	Dim v(2) as Single Dim vV as Variant v(0) = 0.0 : v(1) = 125.5 : v(2) = 50.0 vV = v() ' = VT_R4 VT_ARRAY Array(vV, 3, -2)
--	---

[<Pass start displacement>] <Value> [<ExJnt>] (C2-format)

ex1. @P 1

String	"@P 1"
VARIANT type array (Variable type and pass type specified by string)	Array(1, " ", "@P")
VARIANT type array (Variable type and pass type specified by value)	Array(1,-1,-1)

ex2. @P 1.56

String	"@P 1.56"
VARIANT type array (Variable type and pass type specified by string)	Array(1.56, " ", "@P")
VARIANT type array (Variable type and pass type specified by value)	Array(1.56,-1,-1)

[<Pass start displacement>] (<Element 1>,<Element 2>,...) [<ExJnt>] (C3-format)

ex1. @P (1, 30.0)

String	"@P (1, 30.0)"
VARIANT type array (Variable type and pass type specified by string)	Dim v(1) as Single v(0) = 1 : v(1) = 30.0 Dim vV as Variant vV = v() Array(vV, " ", "@P")
VARIANT type array (Variable type and pass type specified by value)	Dim v(1) as Single v(0) = 1 : v(1) = 30.0 Dim vV as Variant vV = v() Array(vV, -1, -1)

Other examples

ex1. V1,V2,V3

(Rotation plane for CaoRobot::Rotate())

String	"V1,V2,V3"
String array	Array("V1","V2","V3")
VARIANT type array (Variable type specified by string)	Array(Array(1,"V"),Array(2,"V"),Array(3,"V"))
VARIANT type array (Variable type specified by value)	Array(Array(1,3),Array(2,3),Array(3,3))

ex2. APPROACH P,P70, 60, NEXT

(Approach command for CaoRobot::Execute(), without pass specification)

2nd argument: string	.Execute "APPROACH", Array(1, "P70", "60", "NEXT")
3rd argument: string	
2nd argument: VARIANT array	.Execute "APPROACH", Array(1, Array(70, "P"), _ Array(60, "", ""), "NEXT")
3rd argument: VARIANT array	

ex3. APPROACH L,J(60.5,30.3,400,90),@100 70, NEXT

(Approach command for CaoRobot::Execute(), without pass specification)

2nd argument: string	.Execute "APPROACH", Array(2, "J(60.5,30.3,400,90)", "@100 70", "NEXT")
3rd argument: string	
2nd argument: VARIANT array (Raw value, variable type specified by string)	Dim j(3) as Single Dim vJ as Variant j(0) = 60.5 : j(1) = 30.3 : j(2) = 400 : j(3) = 90 vJ = j() ' = VT_R4 VT_ARRAY .Execute "APPROACH", Array(2, Array(vJ, "J"), _ Array(70,"", "@100"), "NEXT")
3rd argument: VARIANT array (Variable type and pass type specified by string)	
2nd argument: VARIANT array (Raw value, variable type specified by string)	Dim j(3) as Single Dim vJ as Variant j(0) = 60.5 : j(1) = 30.3 : j(2) = 400 : j(3) = 90 vJ = j() ' = VT_R4 VT_ARRAY .Execute "APPROACH", Array(2, Array(vJ, "J"), _ Array(70, -1, 100), "NEXT")
3rd argument: VARIANT array (Variable type and pass type specified by value)	

[Notes]

If you specify immediate values directly by POSEDATA type by VT_R4|VT_ARRAY form, the values will be treated as P type and @0 by default. Therefore, data other than P type cannot be specified directly by the VT_R4|VT_ARRAY form. In this case, specify the variable type of the data explicitly by the VT_VARIANT|VT_ARRAY form or VT_BSTR form.

Note that the following codes do not make sense.

```
[PAC] MOVE P, J100
      Dim vJ as Variant
      vJ=CaoCtrl.Variables("J100").Value 'VT_R4|VT_ARRAY
      Robot.Move 1, vJ                 ' Wrong!! = MOVE P, P(<j1>,<j2>,<j3>,...)
```

The correct code is as follows.

```
Robot.Move 1, Array(vJ,"J") ' Variant specification = MOVE P, J(<j1>,<j2>,<j3>,...)
```

Appendix C. Simultaneous Command Issuance to RC8

controller

When the RC8 controller connects with devices through RC8 provider, clients (PCs) and a server (RC8 controller) communicates with b-CAP protocol in each connection (by AddController unit). At that time, the commands transmitted from the client are serialized by the server. Therefore, you need to keep in mind that the following points for the programming on the client side, if you intend to write program that issues multiple commands simultaneously (e.g: monitoring the robot position during robot motion).

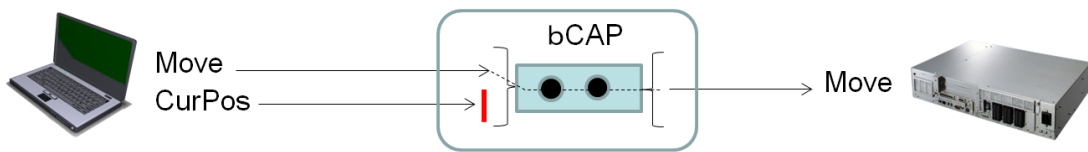

(1) For single-thread

Desynchronize Move command by means of Next option, and then insert CurPos command during the motion termination wait loop.

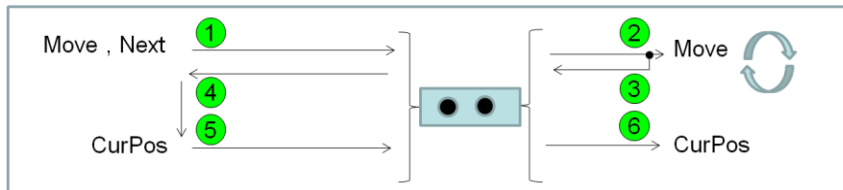

(2) For multi-thread

Create respective threads for the motion execution and the current position monitoring.

Execute CaoWorkspace::AddController for each thread to establish respective connections.

Thread A

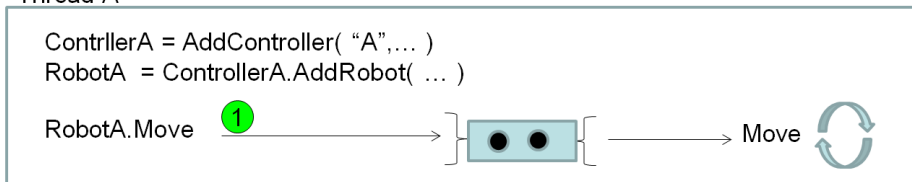

Thread B

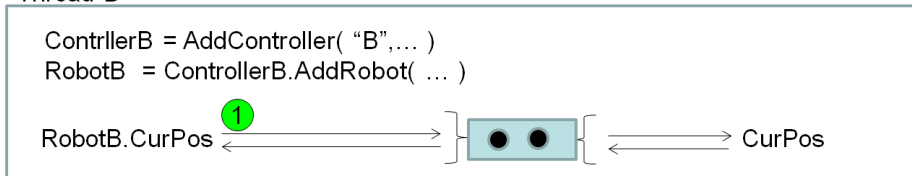

In this example, two threads are used; Thread A executes Move command whereas Thread B executes CurPos command that gets robot's current position. Because Move and CurPos run in the different threads, these can be executed at the same time. Note that you should avoid using the main thread as Thread A, because the main

thread controls GUI. If the main thread is occupied by the motion command, drawing is impeded. Creating a new thread for Thread A is recommended.

Appendix D. Non-Stop Motion Calculator - Trajectory

Generator Command for Non Stop Inspection

To use the Non-stop motion calculator option, you need to input "Non-stop motion calculator" license information in RC8. Please refer "Displaying and Adding/Deleting Function Extension Screen" in DENSO ROBOT USERS MANUALS, that shows how to add the license in RC8. Please see "ORiN2 RC8 Provider "Non-Stop motion calculator" Option User's Guide."

Appendix D.1. Parameters

Following is details of <Position > parameter and <Area> parameter of GenerateNonStopPath command.

<Teaching Position information: VT_VARIANT | VT_ARRAY> =

<X: VT_R8>,

<Y: VT_R8>,

<Z: VT_R8>,

<RX: VT_R8>,

<RY: VT_R8>,

<RZ: VT_R8>,

<Fig: VT_I8>,

<J7: VT_R8>,

<J8: VT_R8>,

< Motion Speed: VT_R8>=

The speed ratio when the robot passes through each path point

It is calculated by dividing the value of motion option (SPEED) at Move by 100. (0.0 to 1.0),

< Motion Pattern: VT_I4> = (0: @P, 1: @0, 2: @E),

< Tool Number : VT_I4>

< Area Information: VT_R4 | VT_ARRAY > =

< Area Size X: VT_R8>,

< Area Size Y: VT_R8>,

< Area Size Z: VT_R8>,

< Area Angle: VT_R8>,

< Area Size J7: VT_R8>,

< Area Size J8: VT_R8>

Appendix D.2. Error Codes

If the "GenerateNonStopPath" command defined in the provider fails, an error code "0x8150015E" is issued. The custom error code list for the command and recovery are shown in the below table. To check the custom error code, from the robot controller which is being connected, select [Display Error detail] – [Original number].

Number (original number)	Contents	Recovery
0x2000****	Conversion Error from Position to Joint (Teaching Data)	The teaching point that an error occurred is the place to which the robot is unable to move. Change the coordinates of the teaching point.
0x2100****	Software limit Error (Teaching Data)	The teaching point that an error occurred is the place to which the robot is unable to move. Change the coordinates of the teaching point.
0x2200****	Out of Speed Rate Range	Change the value of element <Motion speed> (see Appendix D.1 Parameters) of argument <Teaching Points> of the teaching point that an error occurred. (Valid range: 0.0 to 1.0)
0x2300****	Conversion Error from Position to Joint (Revised Data)	Execute one or several remedies from the following proceedings; <ul style="list-style-type: none"> • Change the coordinates of the teaching point that an error occurred. • Set the dummy point in front of the teaching point that an error occurred. • Set the dummy point back of the teaching point that an error occurred. • Change the parameters of Appendix D.5.
0x2400****	Software limit Error (Revised Data)	Execute one or several remedies from the following proceedings; <ul style="list-style-type: none"> • Change the coordinates of the teaching point that an error occurred. • Set the dummy point in front of the teaching point that an error occurred. • Set the dummy point back of the teaching point that an error occurred.

0x2500****	Revision operation convergence is impossible	Execute one or several remedies from the following proceedings; <ul style="list-style-type: none"> • Change the coordinates of the teaching point that an error occurred. • Set the dummy point in front of the teaching point that an error occurred. • Set the dummy point back of the teaching point that an error occurred.
0x2600****	Too near teaching points (Position and Posture)	Execute one or several remedies from the following proceedings; <ul style="list-style-type: none"> • Change the coordinates of the teaching point that an error occurred. • Set the dummy point in front of the teaching point that an error occurred. • Set the dummy point back of the teaching point that an error occurred.
0x2A00****	Joint Flag must be set as "limited rotation".	Change to the limited rotation of extra-joint.
0x2F000000	Out of total speed rate range	Modify the argument <Total Speed Rate>. (Valid range: 0.0 to 1.0)
0x2F010000	Out of Coefficients Range	Modify the argument <Convergence Coefficient>. (Valid range: 0.0 to 1.0)
0x2F030000	Low Memory	After restarting the controller, execute again. If not recovered, contact us, Denso service representative.
0x2F0A0000	Out of Data Number	Modify the argument <Teaching Point Number >. (Valid range: 0 to 200)

Error Code: 0x2000**** - 0x2800****

The symbol of "*" represents the error occurred position number. The value is "the error occurred position number - 1".

Error Code: 0x2A00****

The symbol of "*" represents the number of the axis which is set as "unlimited rotation".

Appendix D.3. Restrictions

Restrictions of GenerateNonStopPath Command are as follows:

- Maximum number of Teaching Points = 200
- Available for 6-axis robot only
- Area size for additional axis should be assigned in [degree] (for rotational axis) or [mm] (for linear axis) according to the axis setting.
- Unavailable for Unlimited rotation of the extra-joint

Appendix D.4. Sample Program

The following sample program is described in CaoScript. The following sample teaching data is for VS-6577G-BA robot. Assign appropriate IP address for the target controller. This sample assumes the target controller IP address is 10.6.235.72.

Sample	NonStopPath.vbs
--------	-----------------

```
' Generate NonStopPath
Const RC_ADDRESS = "10.6.235.72"

Sub Main
    Dim rc
    Dim vntTeachPos()
    Dim vntAreaInfo()
    Dim vntMovePos
    Dim vntParam
    Dim lIndex

    dbg.ClearLog

    set rc = cao.AddController("RC", "CaoProv.DENSO.RC8", "", "server=" & RC_ADDRESS)
    set rob = rc.AddRobot("Robot")

    ' GenerateNonStopPath Command Parameter(Pos, Area, Size, SpdRate, Coef)
    ' Pos : TeachPoint Data(x, y, z, rx, ry, rz, fig, J7, J8, SpdRate, attr, ToolNum)
    redim vntTeachPos(7)

    vntTeachPos(0) = Array(300.0, 100.0, 600.0, 180.0, 0.0, 180.0, 5, 0.0, 0.0, 100 * 0.01, 1, 0)
    vntTeachPos(1) = Array(300.0, 91.0, 600.0, 180.0, 0.0, -180.0, 5, 0.0, 0.0, 100 * 0.01, 0, 0)
    vntTeachPos(2) = Array(310.0, 30.0, 600.0, 180.0, 0.0, -180.0, 5, 0.0, 0.0, 100 * 0.01, 1, 0)
    vntTeachPos(3) = Array(315.5, 24.5, 600.0, 180.0, 0.0, -180.0, 5, 0.0, 0.0, 100 * 0.01, 0, 0)
    vntTeachPos(4) = Array(300.0, 10.0, 600.0, 180.0, 0.0, 173.0, 5, 0.0, 0.0, 100 * 0.01, 1, 0)
    vntTeachPos(5) = Array(300.0, 10.0, 600.0, 180.0, 0.0, 176.0, 5, 0.0, 0.0, 100 * 0.01, 0, 0)
    vntTeachPos(6) = Array(300.0, 10.0, 600.0, 180.0, 0.0, 171.0, 5, 0.0, 0.0, 100 * 0.01, 0, 0)
    vntTeachPos(7) = Array(300.0, 10.0, 600.0, 180.0, 0.0, -180.0, 5, 0.0, 0.0, 100 * 0.01, 1, 0)

    ' Area : Area Info(x, y, z, angle, J7, J8)
    redim vntAreaInfo(7)

    vntAreaInfo(0) = Array(4,4,4,4,0,0)
    vntAreaInfo(1) = Array(4,4,4,4,0,0)
    vntAreaInfo(2) = Array(4,4,4,4,0,0)
    vntAreaInfo(3) = Array(4,4,4,4,0,0)
    vntAreaInfo(4) = Array(4,4,4,4,0,0)
    vntAreaInfo(5) = Array(4,4,4,4,0,0)
    vntAreaInfo(6) = Array(4,4,4,4,0,0)
    vntAreaInfo(7) = Array(4,4,4,4,0,0)
```

```

dbg.Output "Teach Points"
for lIndex = 0 to Ubound(vntTeachPos)
    dbg.Output lIndex & " : " & dat.BstrFromVariant(vntTeachPos(lIndex))
next

' -----
' Generate NonStopPath
' -----

vntMovePos = rob.Execute("GenerateNonStopPath", Array(vntTeachPos, vntAreaInfo,
Ubound(vntTeachPos) + 1, 100.0 * 0.01, 0.7))

dbg.Output "Move Points"
for lIndex = 0 to Ubound(vntMovePos)
    dbg.Output lIndex & " : " & dat.BstrFromVariant(vntMovePos(lIndex))
next

End Sub
    
```

Appendix D.5. Workaround at the time of the Adjustment Failure (Error Code [original number]:0x8150015E[0x2300****])

If the GenerateNonStopPath command fails, the teaching point coordinates under adjustment might exceed the maximum adjustment angle range against robot axes. If the failure occurs and the error code [original number] is “0x8150015E[0x2300xxxx]” (xxxx represents teaching position number), change the teaching position, or adjust parameters for the selected Adjustment Method as shown below.

Adjust the following parameters in [F2 Arm] - [F6 Aux] - [F1 Config].

Parameter	Outline	Input Limitation
FIGCHECK.MAX_DISPLACEMENT_dJ1	Offset of Maximum Adjustment Angle for 1st axis (deg)	-21474.8 to 21474.8
FIGCHECK.MAX_DISPLACEMENT_dJ2	Offset of Maximum Adjustment Angle for 2nd axis (deg)	-21474.8 to 21474.8
FIGCHECK.MAX_DISPLACEMENT_dJ3	Offset of Maximum Adjustment Angle for 3rd axis (deg)	-21474.8 to 21474.8
FIGCHECK.MAX_DISPLACEMENT_dJ4	Offset of Maximum Adjustment Angle for 4th axis (deg)	-21474.8 to 21474.8
FIGCHECK.MAX_DISPLACEMENT_dJ5	Offset of Maximum Adjustment Angle for 5th axis (deg)	-21474.8 to 21474.8
FIGCHECK.MAX_DISPLACEMENT_dJ6	Offset of Maximum Adjustment Angle for 6th axis (deg)	-21474.8 to 21474.8
FIGCHECK.MAX_DISPLACEMENT_dJ7	Offset of Maximum Adjustment Angle for 7th axis (deg)	-21474.8 to 21474.8
FIGCHECK.MAX_DISPLACEMENT_dJ8	Offset of Maximum Adjustment Angle for 8th axis (deg)	-21474.8 to 21474.8