

For HSR / HSA1 Straight

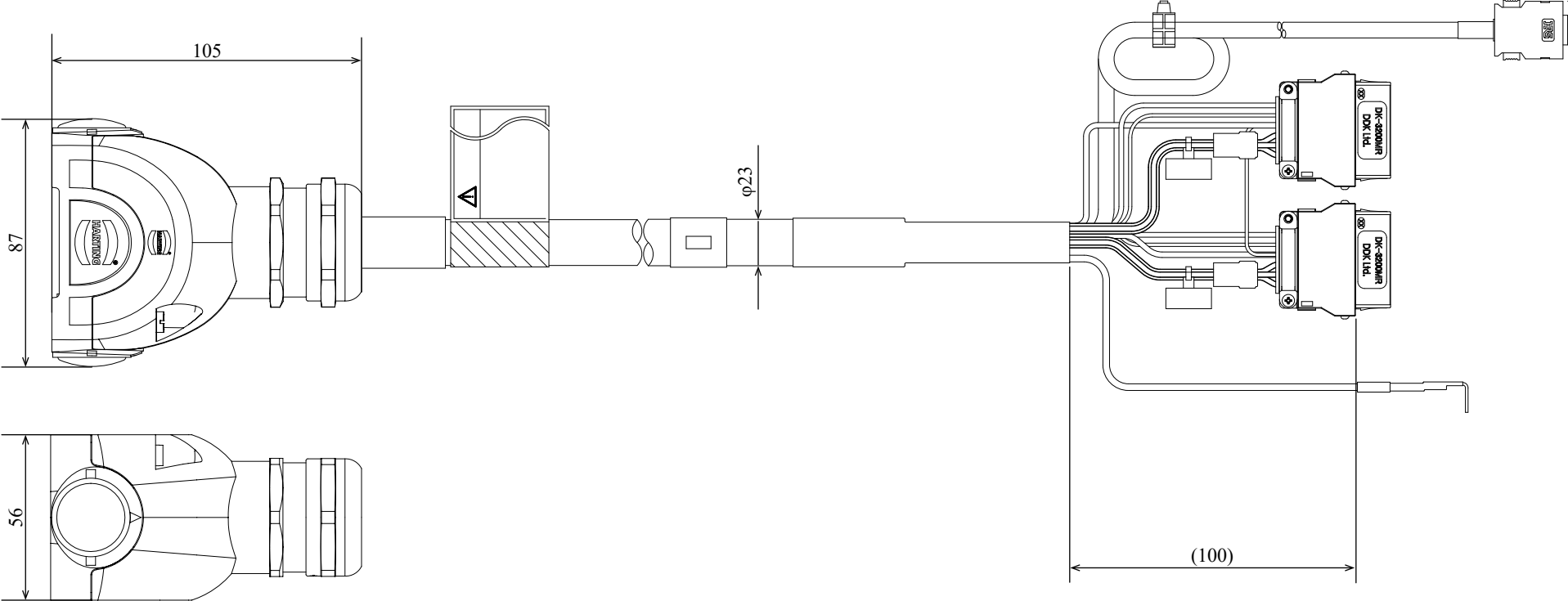

The bending radius (internal) of a motor & encoder cable should be at least 33.8 mm when the cable is stationary, and at least 225 mm when it is movable. Excessively bending will result in broken lead wires.

If the length of the motor and encoder cable is 20 m, the leakage current of power supply exceeds 3.5 mA. To reduce the touch current on the controller surface to 3.5 mA or less, take any measures, for example, connecting additional protective earthing conductor which cross section is 2.5mm² or larger to the controller.

HSR Straight Connector

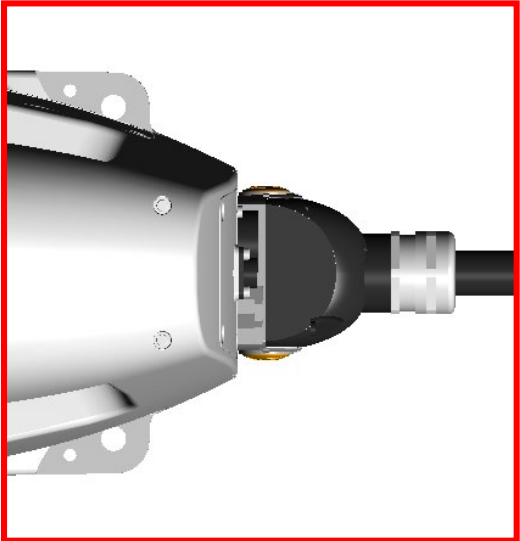
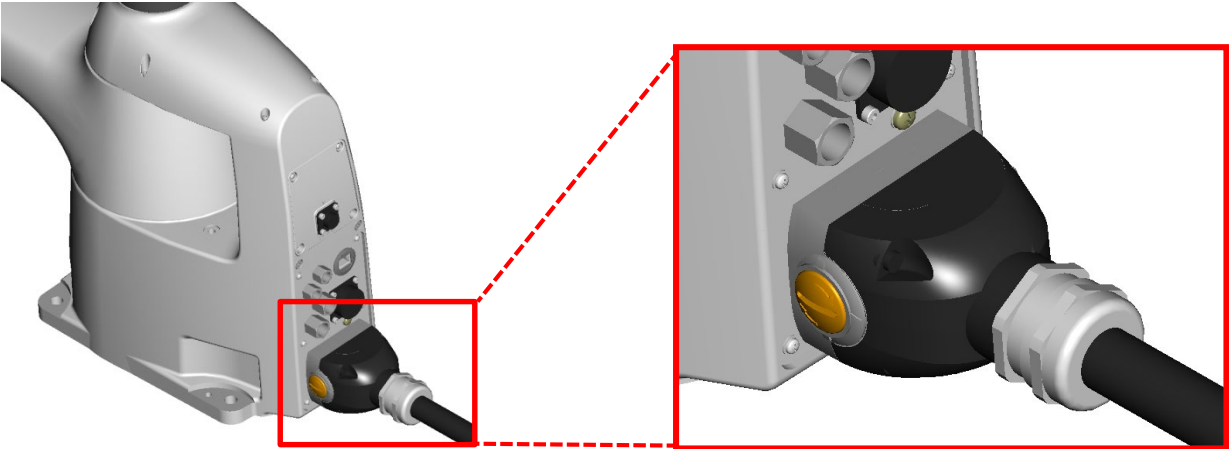

TOP VIEW

HSA1 Straight Connector

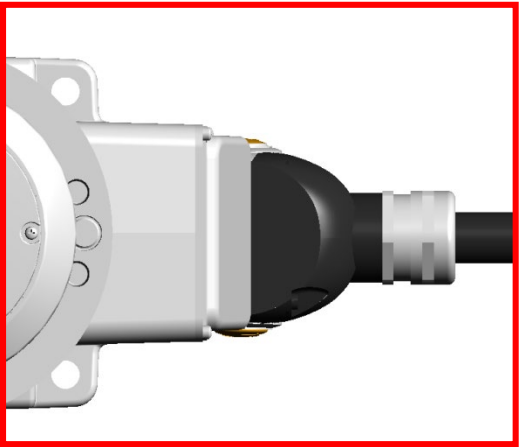
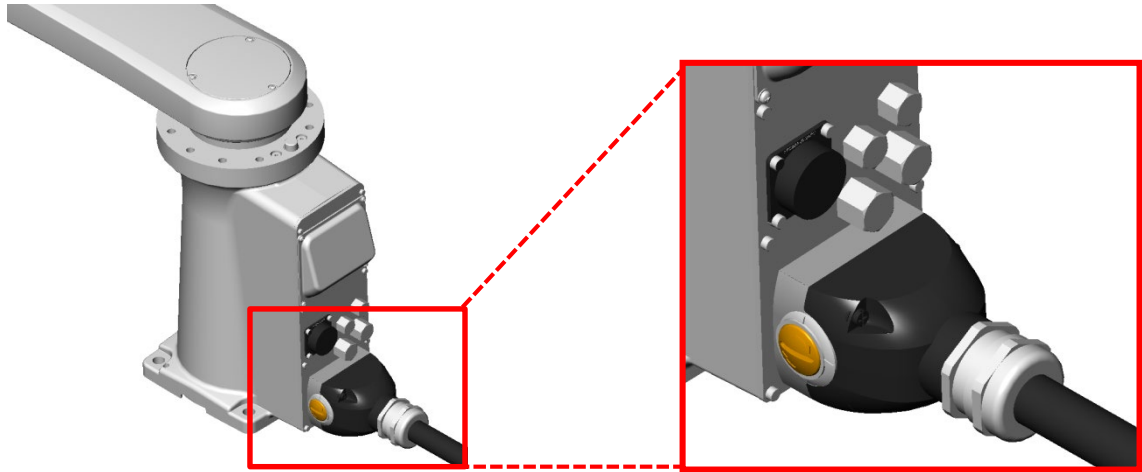

TOP VIEW