

View in direction of arrow (A)

View in direction of arrow (B)

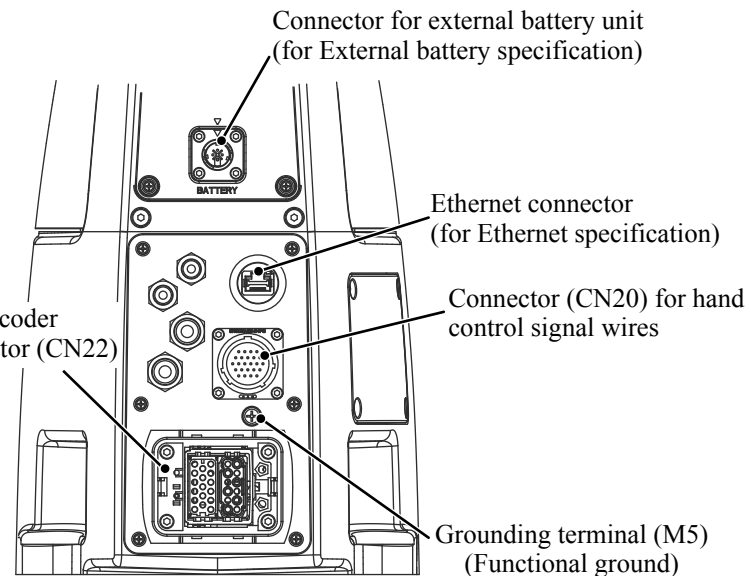

CN21 pin layout

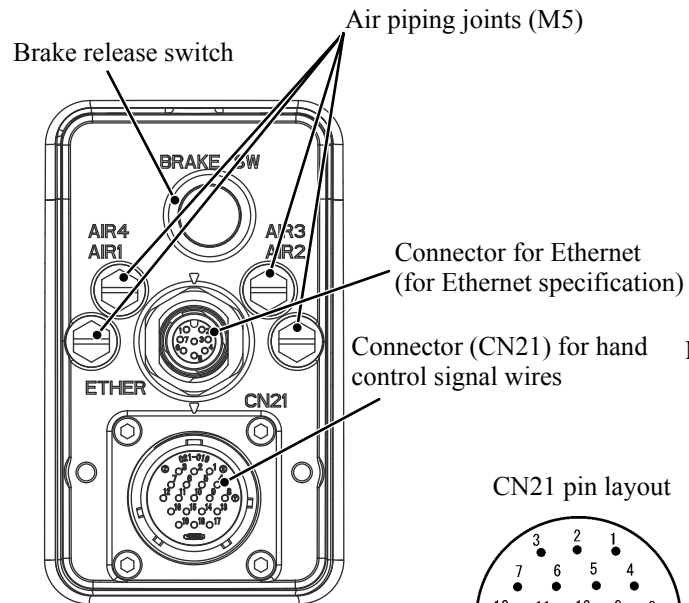
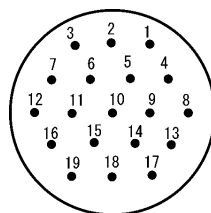

CN20 pin layout

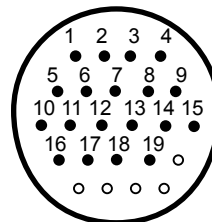

Pin assignment on Ethernet connector

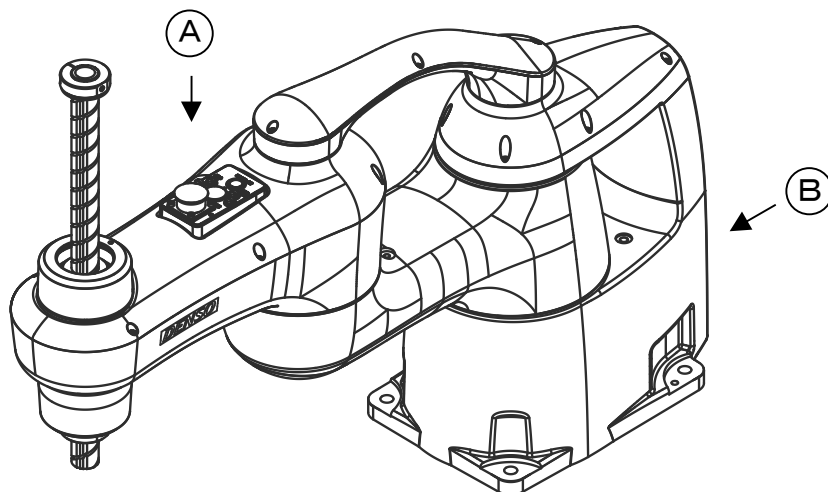
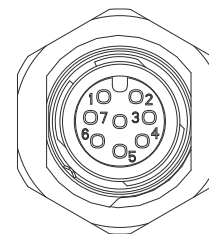

AIR No.	Air piping joint	Maximum allowable pressure
AIR 1,2	φ4, PT1/8	0.59 MPa
AIR 3,4	φ6, PT1/4	