

Item	Feet
Material	Refer to the diagram
Surface painting	Painting

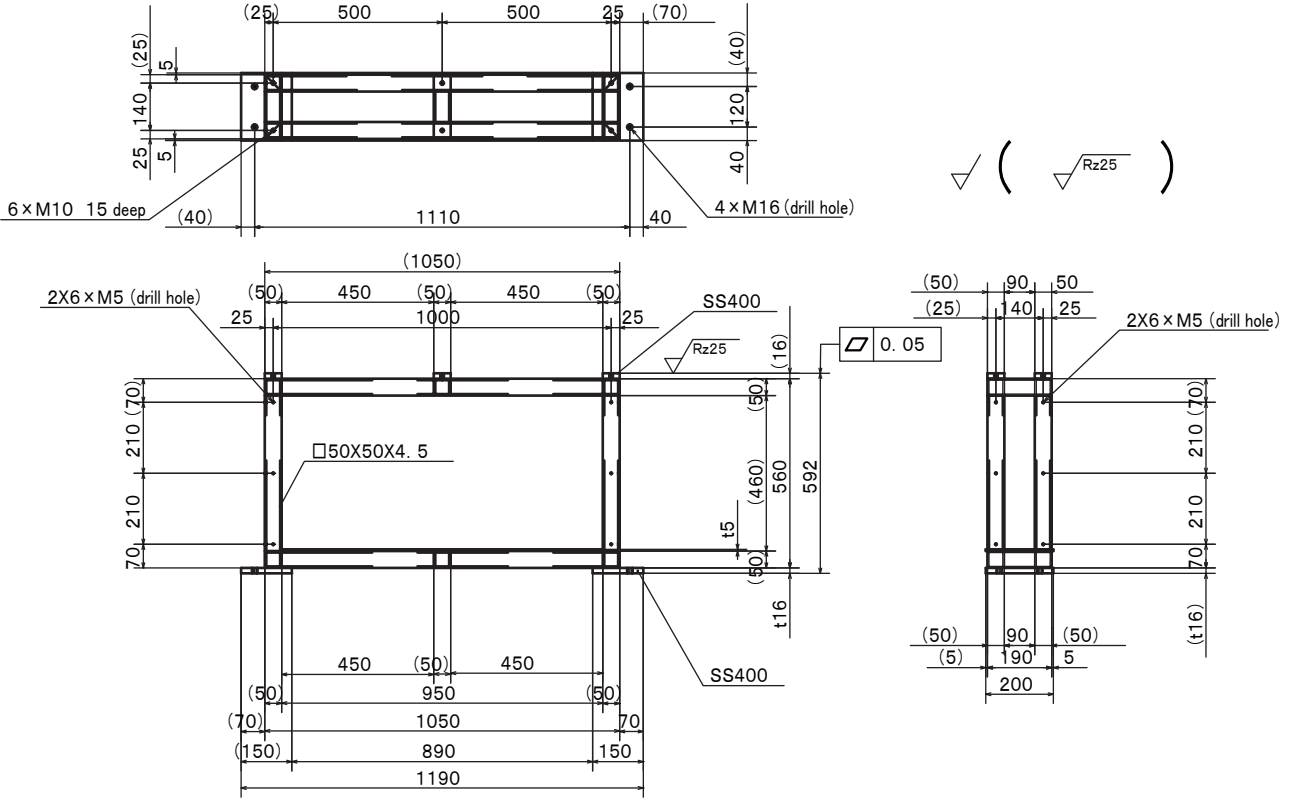

Item	Plate
Material	SS400

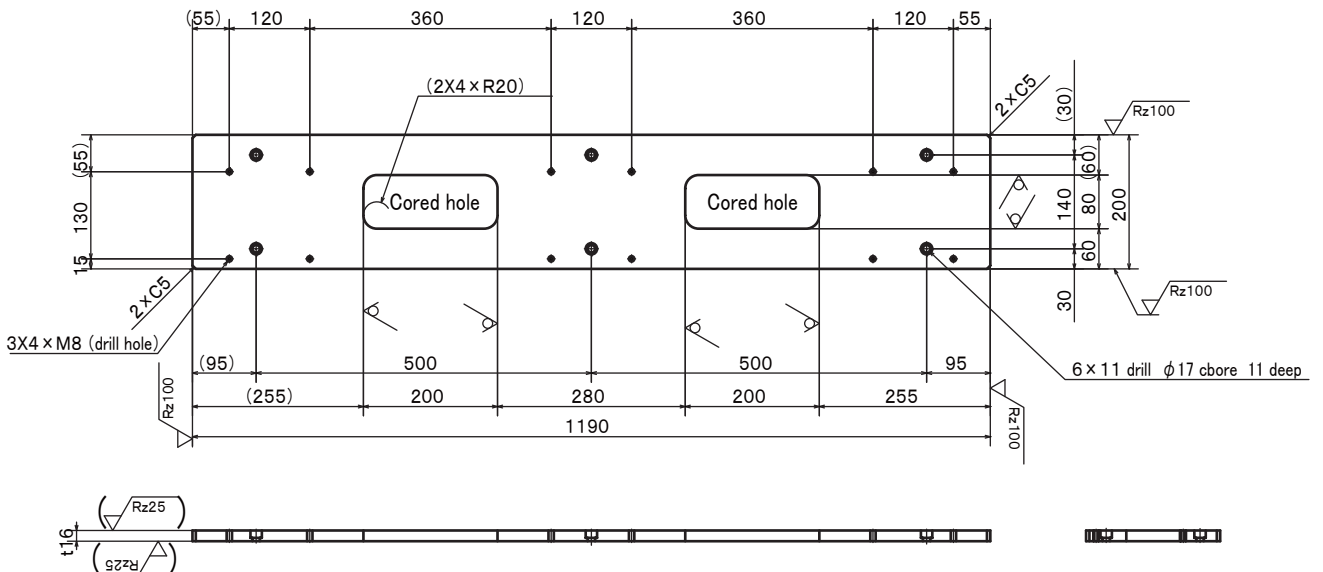

Item	Support
Material	SS400
Surface painting	Painting

√(√Rz 100 √Rz 25 √Rz 6.3)

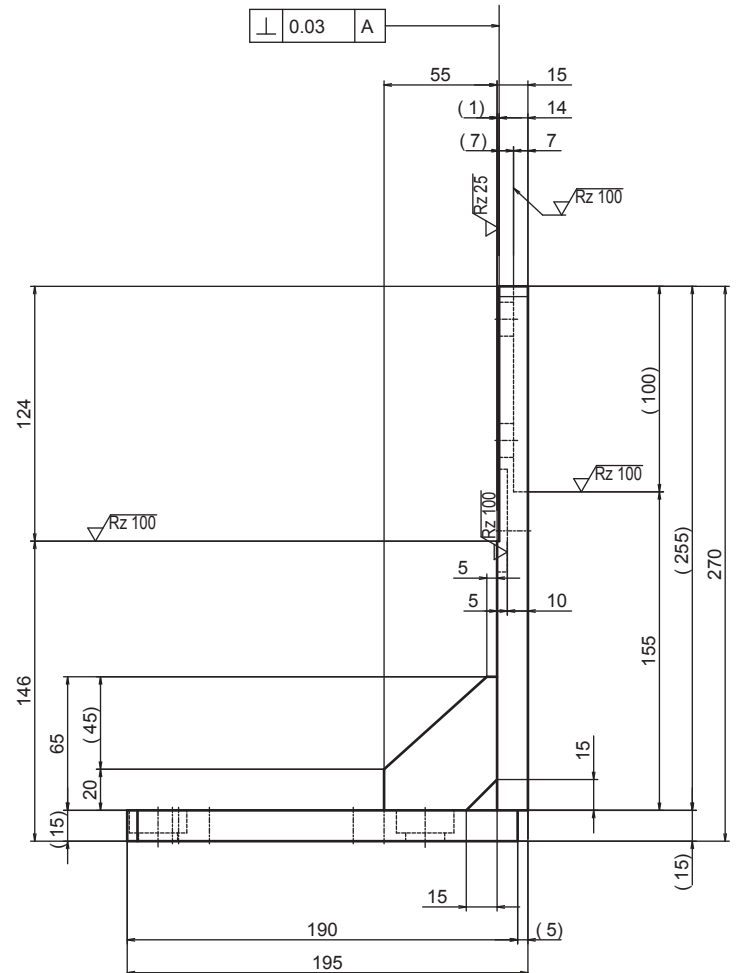
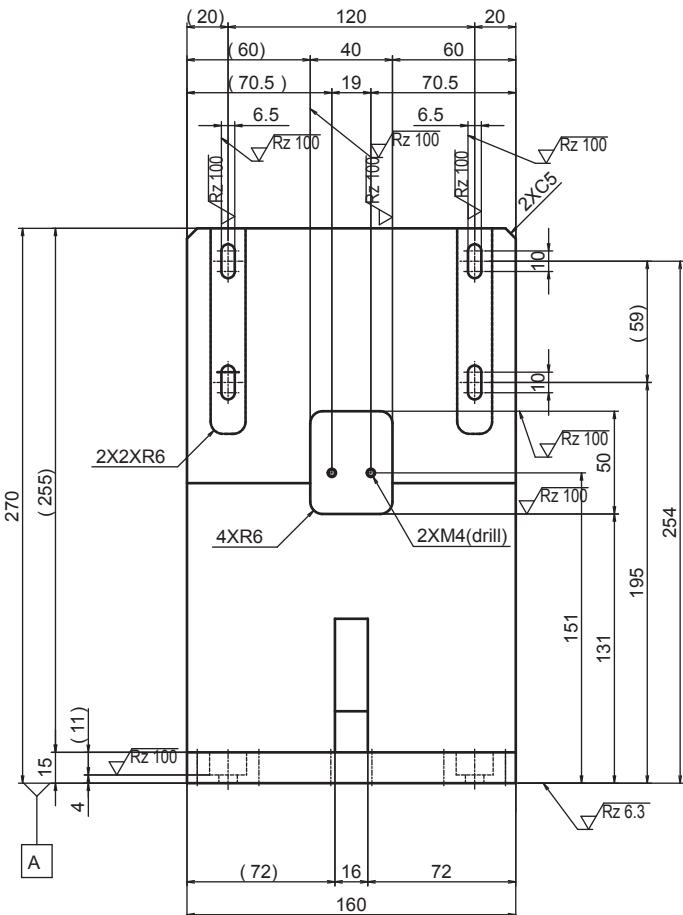
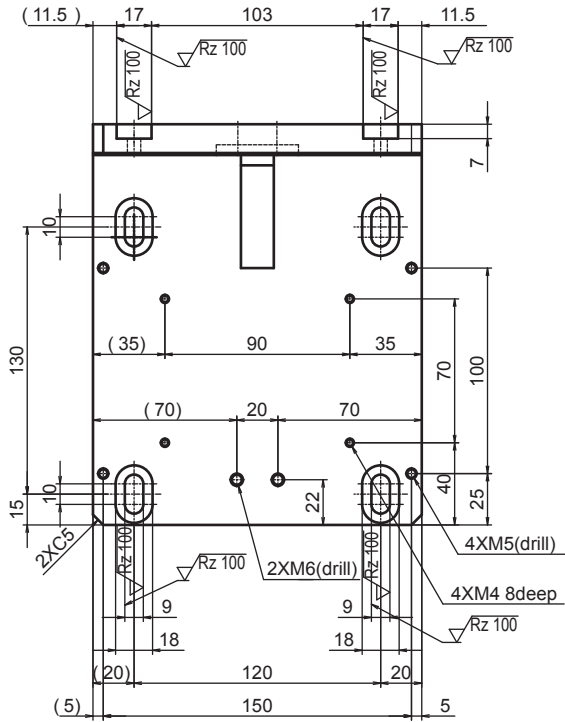

* JOINTS SHALL BE WELDED