

TP/MP

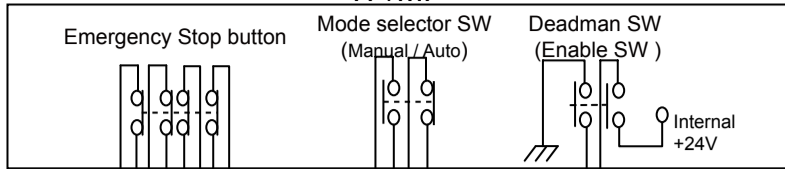

Minil/O Robot controller

Prepared by customer

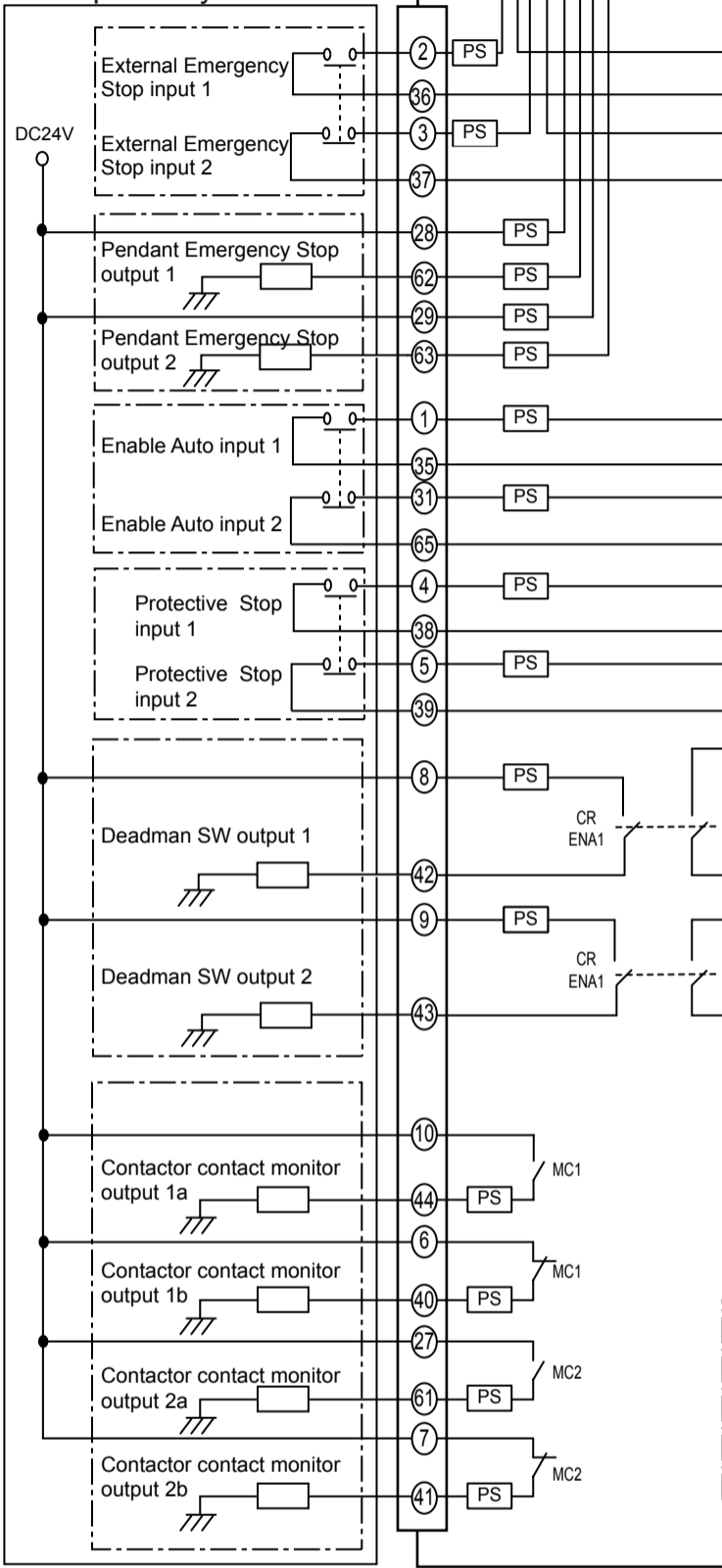

Safety I/O Circuit Operation description (operation conditions for contactors)

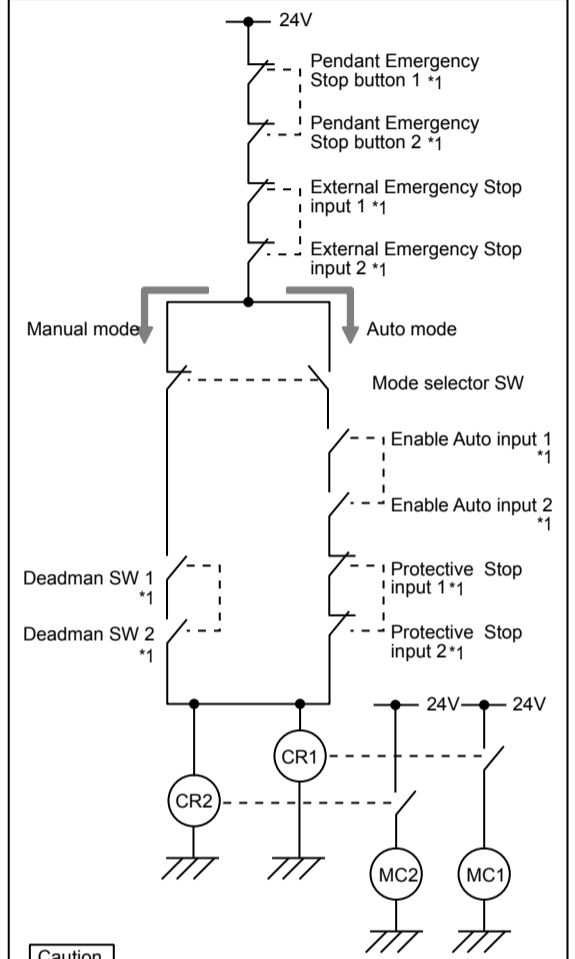

Caution
 *1 : Checks condition by test pulse.
 - - - : Contact points which behave in conjunction with each other.

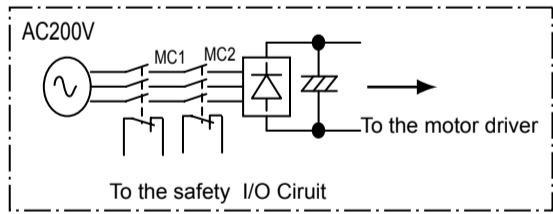

PS:Self-recovery fuse(Max.0.15A)