

TP/MP

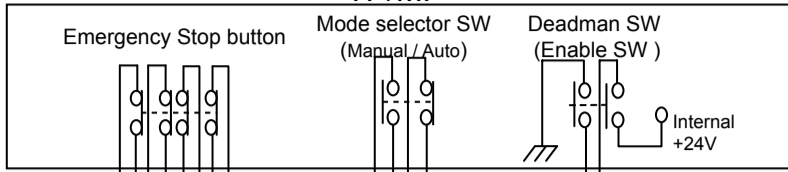

Mini I/O

Robot controller

Prepared by customer

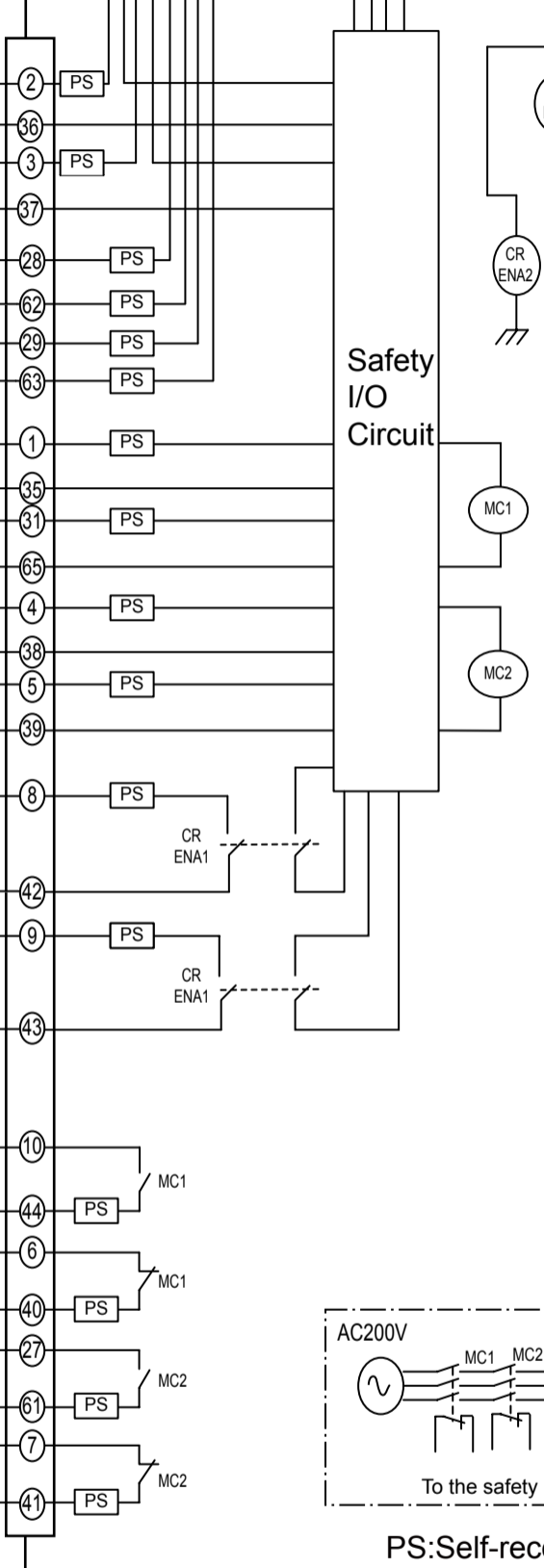
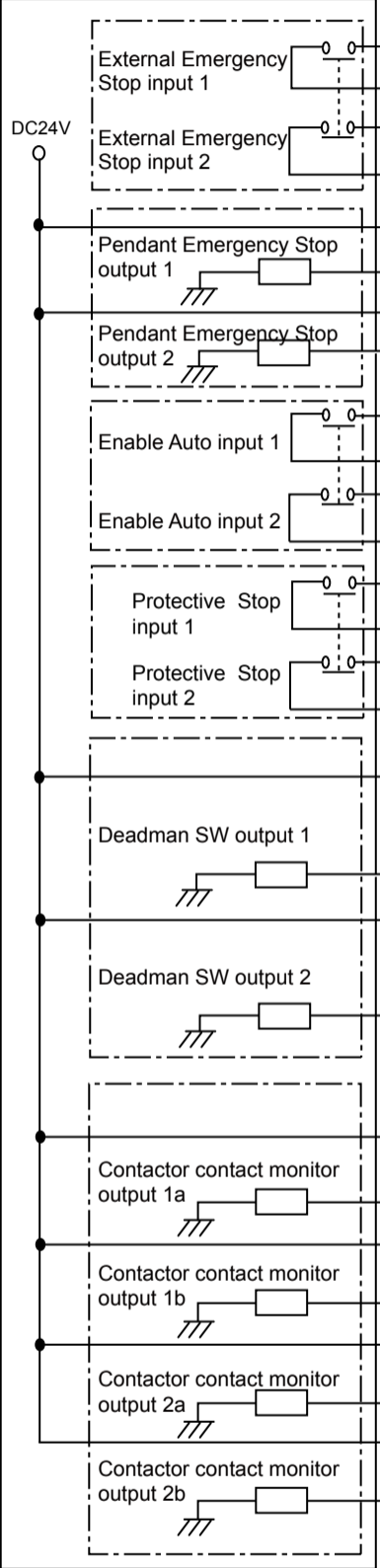

Safety I/O Circuit (operation conditions for contactors)

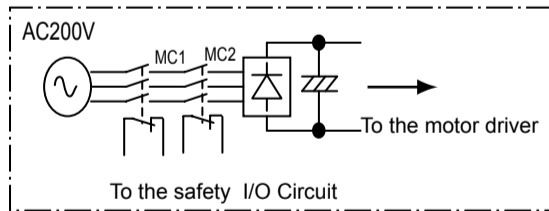
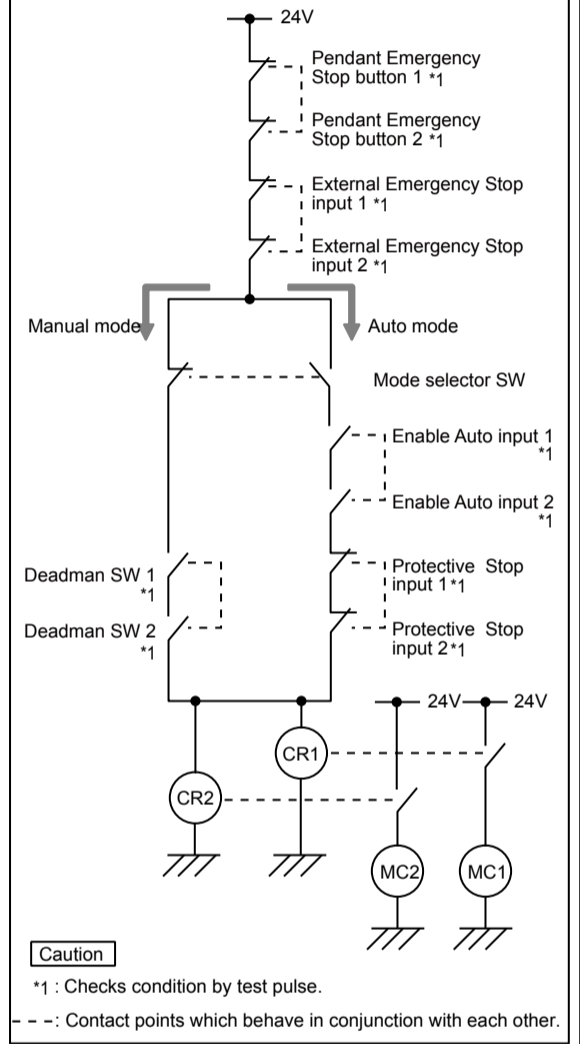

PS: Self-recovery fuse (Max. 0.15A)