

Sample wiring diagram for three or more robots

Master Controller

Not Supplied

Enable Auto (input)	1
	35
	65
Protective Stop (input)	4
	38
	5
+24V	32
	33
	34
External Emergency Stop (input)	2
	36
	37
Pendant Emergency Stop (output)	28
	62
	29
Contactor for monitor output	10
	44
	27
0V	66
	67
	68

Teach pendant or dummy connector

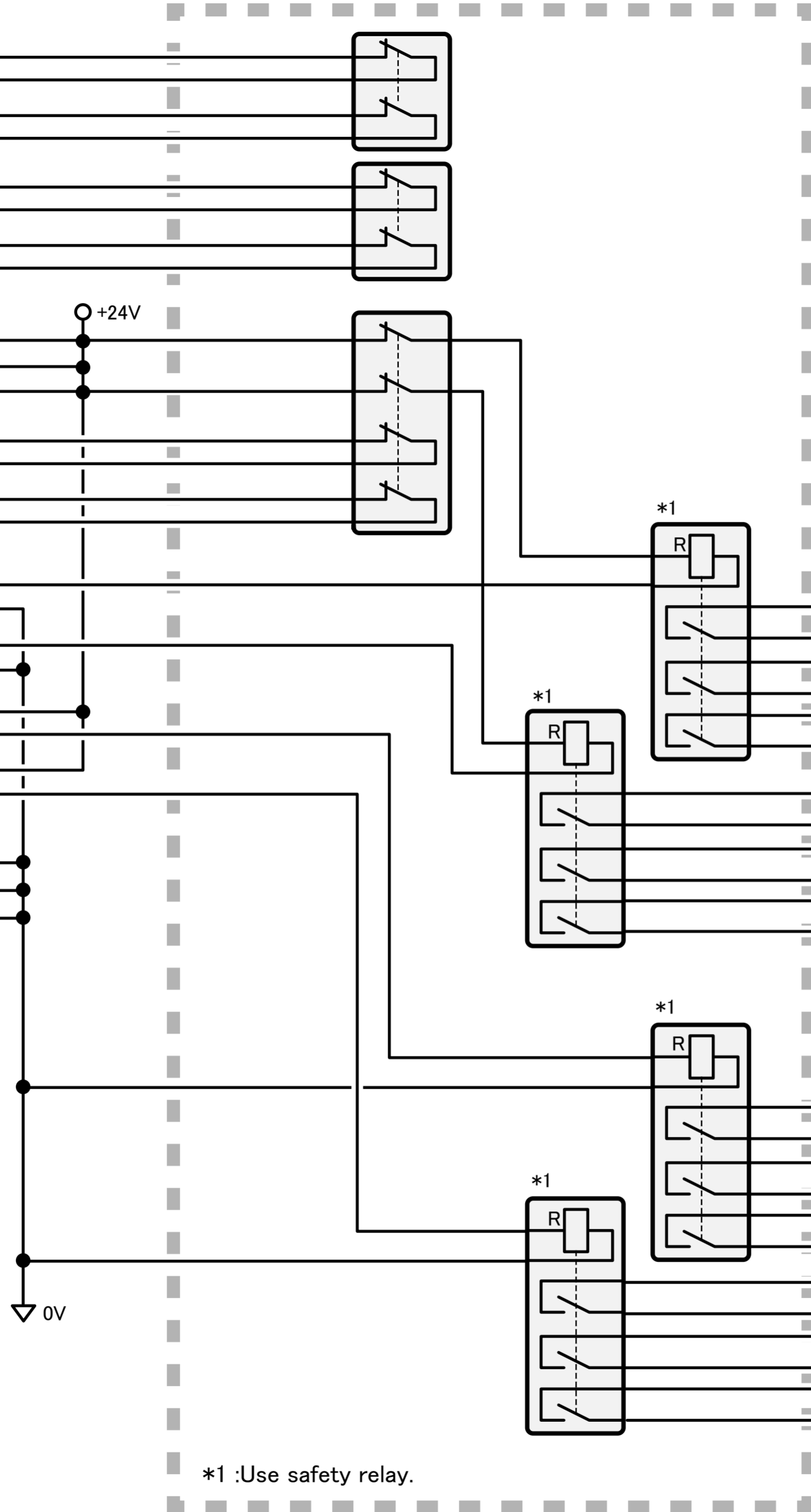

*1 :Use safety relay.

Slave Controller

Protective Stop (input)	4
	38
	5
External Emergency Stop (input)	2
	36
	3
Enable Auto (input)	37
	1
	35
	31
	65

Slave Controller

Protective Stop (input)	4
	38
	5
External Emergency Stop (input)	2
	36
	3
Enable Auto (input)	37
	1
	35
	31
	65

Slave Controller

Protective Stop (input)	4
	38
	5
External Emergency Stop (input)	2
	36
	3
Enable Auto (input)	37
	1
	35
	31
	65