

Detailed drawing of end-effector mounting face

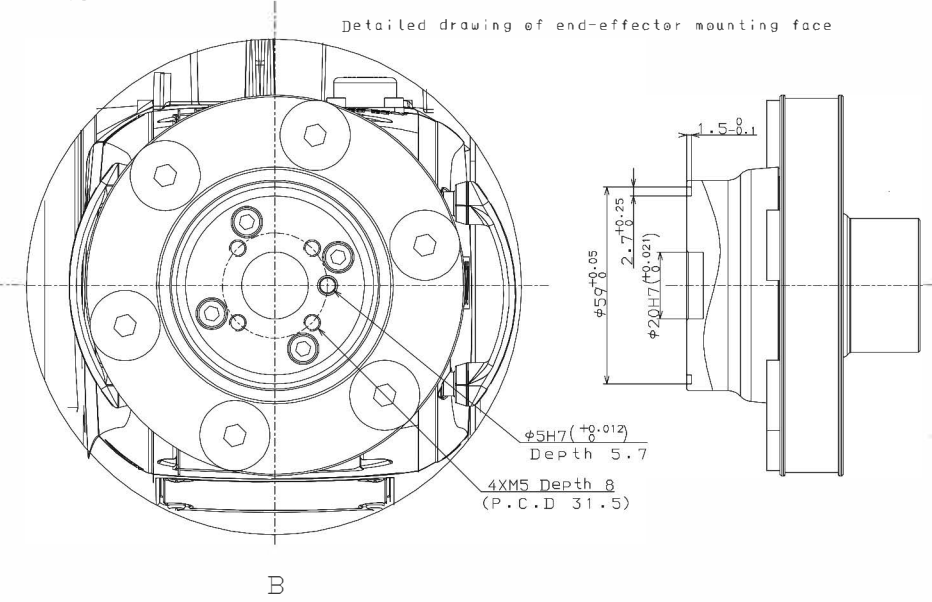

defined by point P
workable space

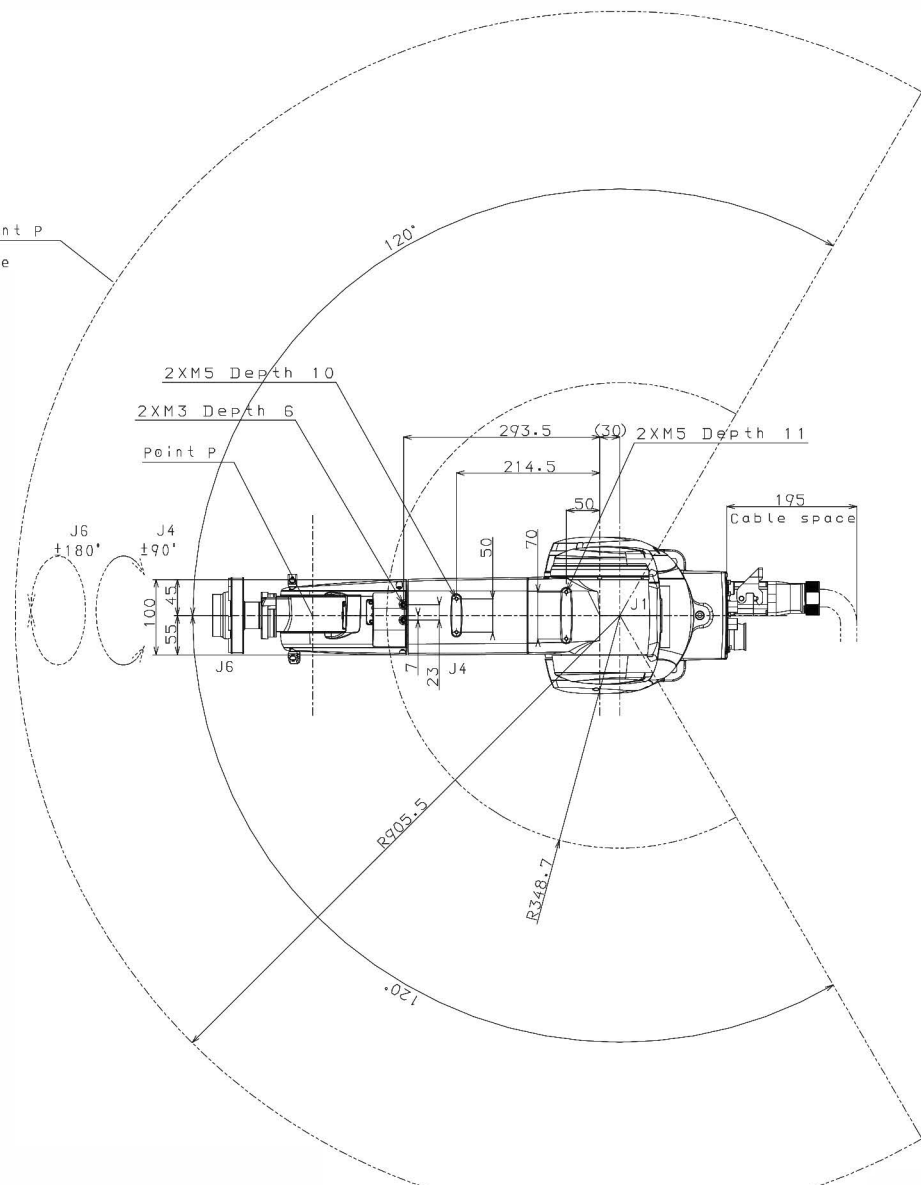

J1=±120°
 J2=+90°, -70°
 J3=+140°, -20°
 J4=±90°
 J5=+110°, -100°
 J6=±180°

Detailed drawing of base mounting face

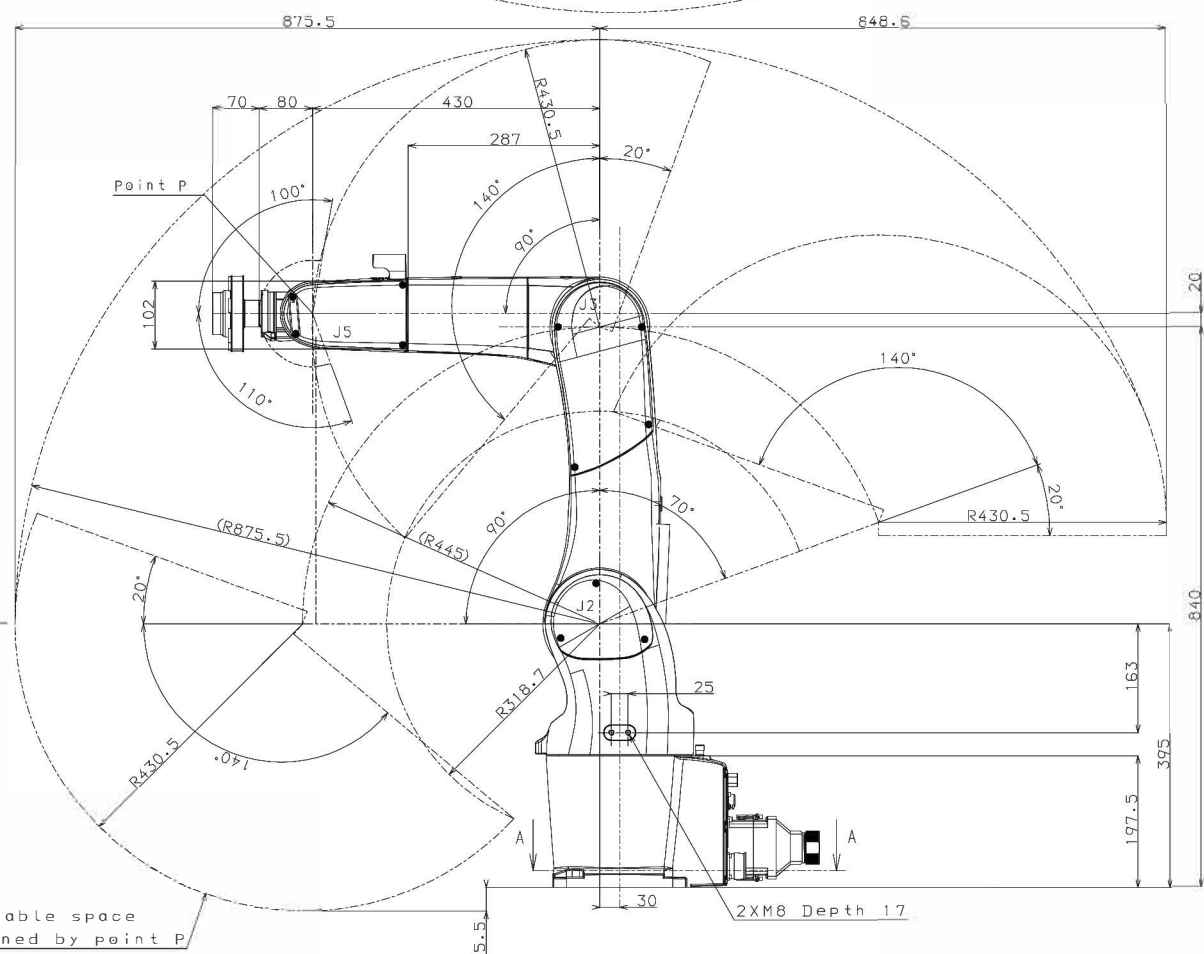
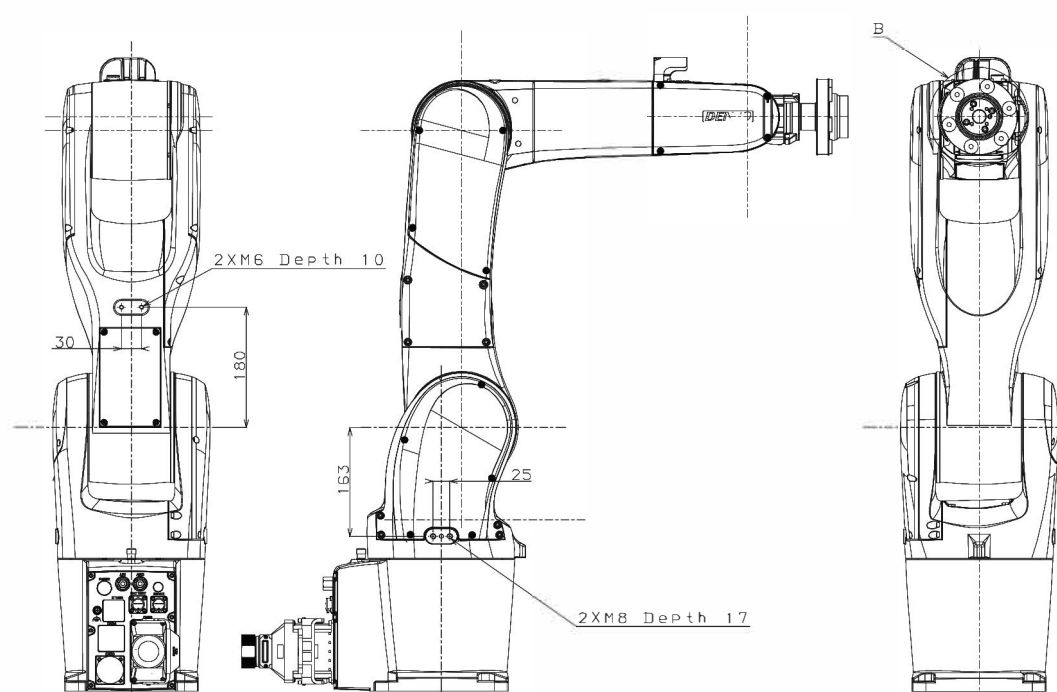
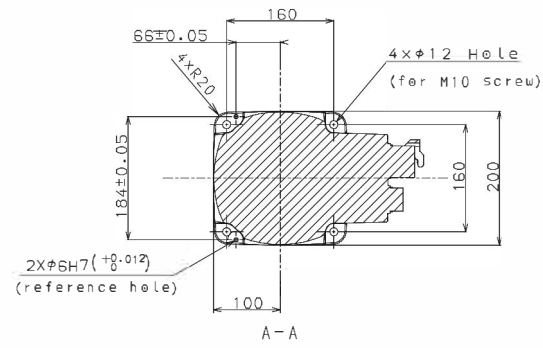

workable space
defined by point P