

√ (√ Rz 100 √ Rz 25)

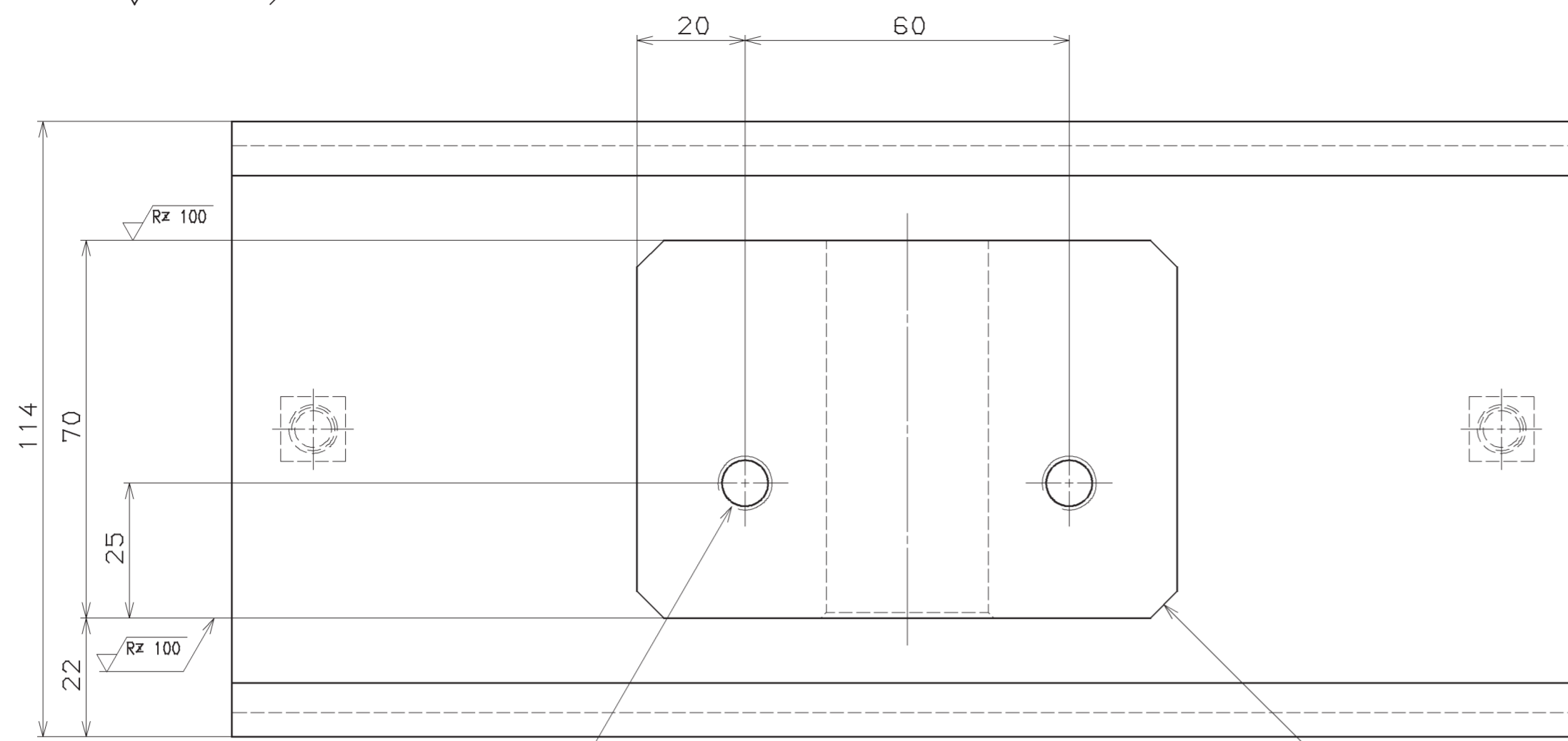

2XM10 Depth 22
Drill depth 27

4XC5

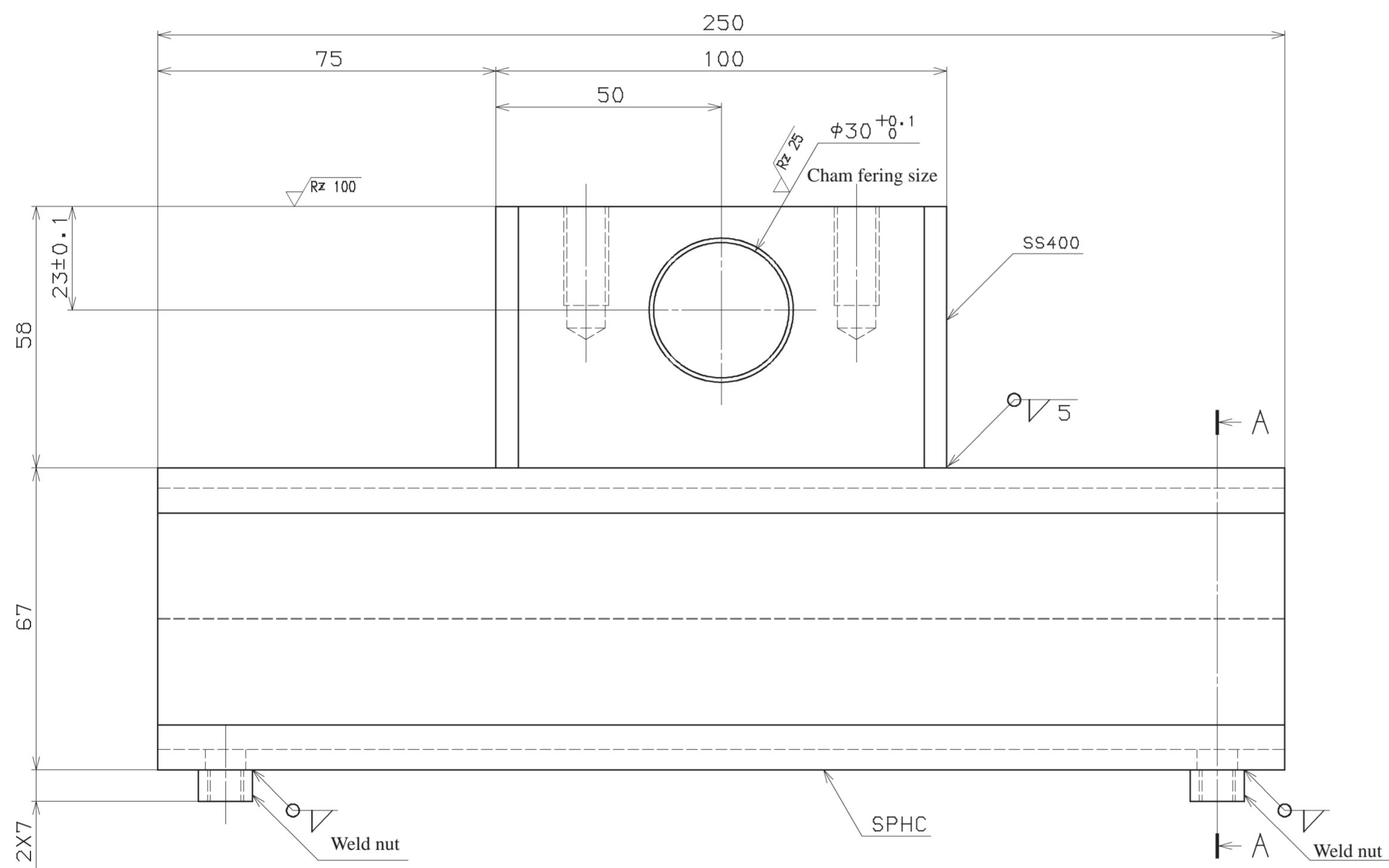

SS400

$\nabla 5$

A

SPHC

A

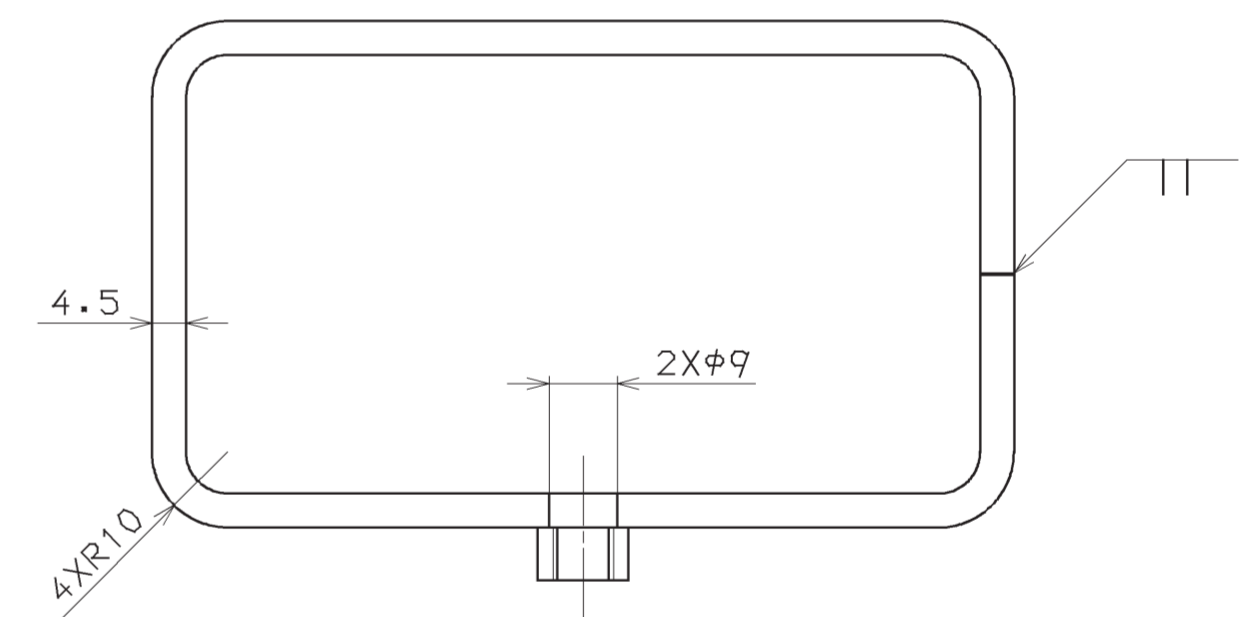

A - A

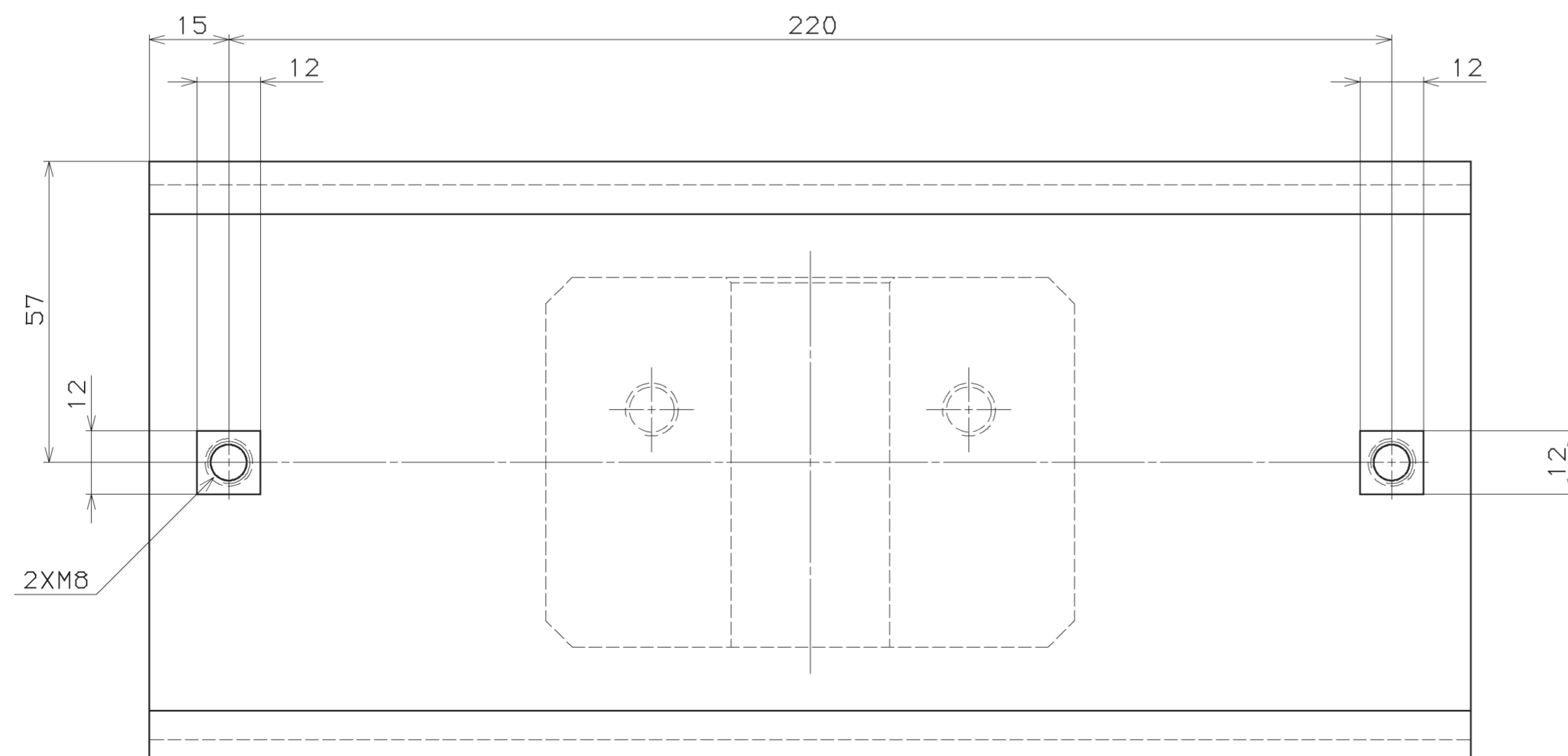

2XM8

MATERIAL : SS400, SPHC