

<HSS-4555*G>

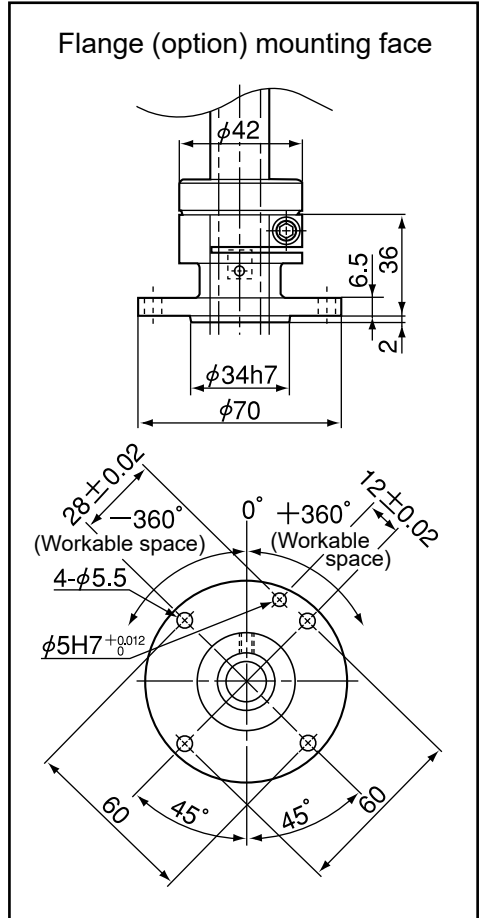

Unit: mm

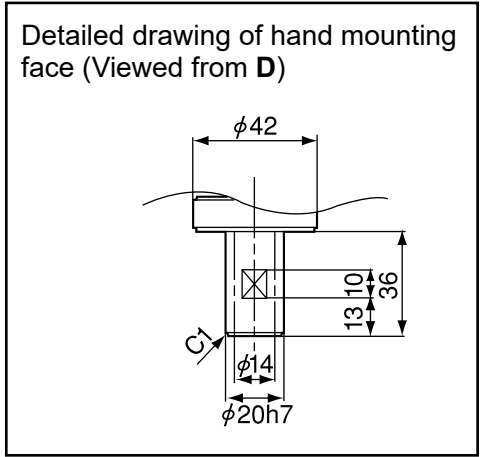
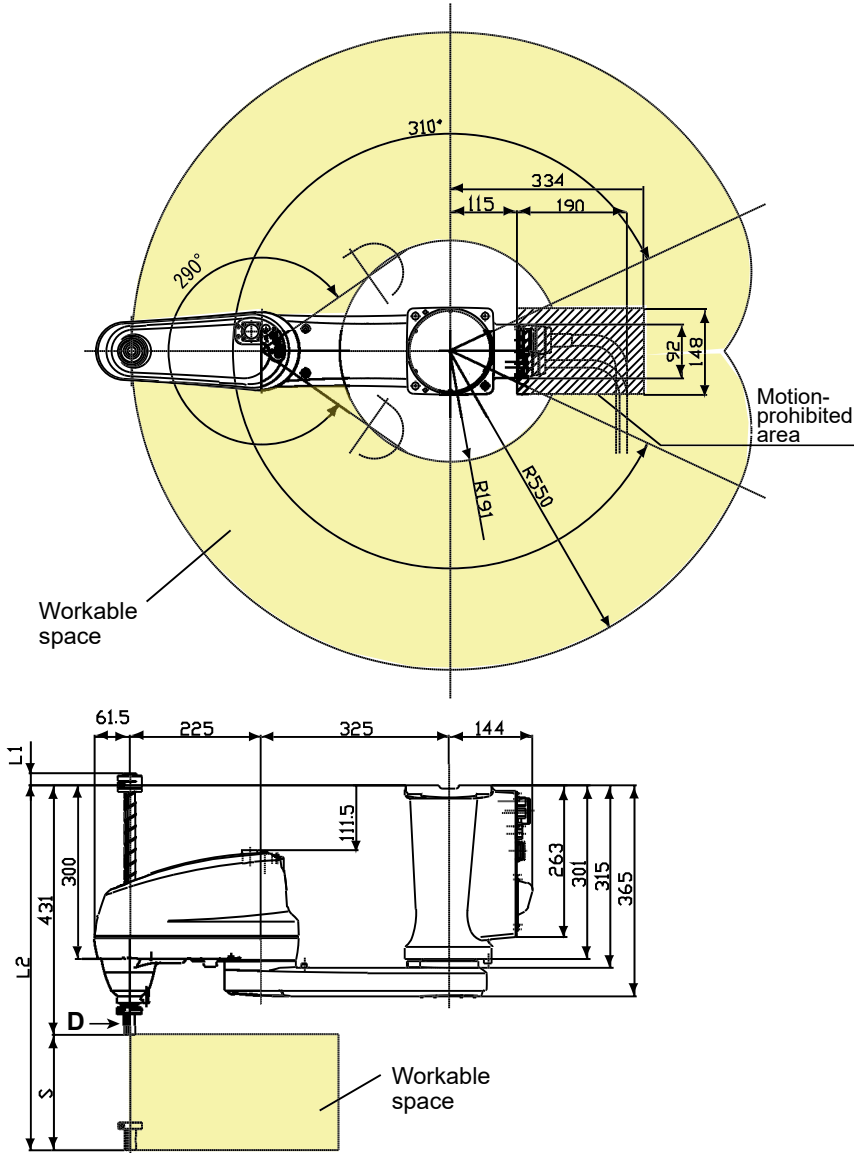
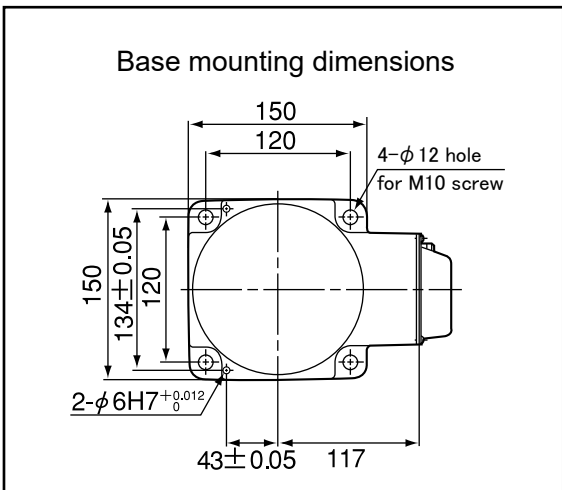

NOTE: Dimensions that differ according to Z-axis stroke (S)

Model	S	L1	L2
HSS-45551G	150	-30	581
HSS-45552G	200	20	631
HSS-45553G	320	140	751

NOTE: In the case of the overhead-mount type, the Z axis in the uppermost position may reach higher than the base mounting face. Be careful with the interference with surrounding facilities.