

<HSS-4545*G-W>

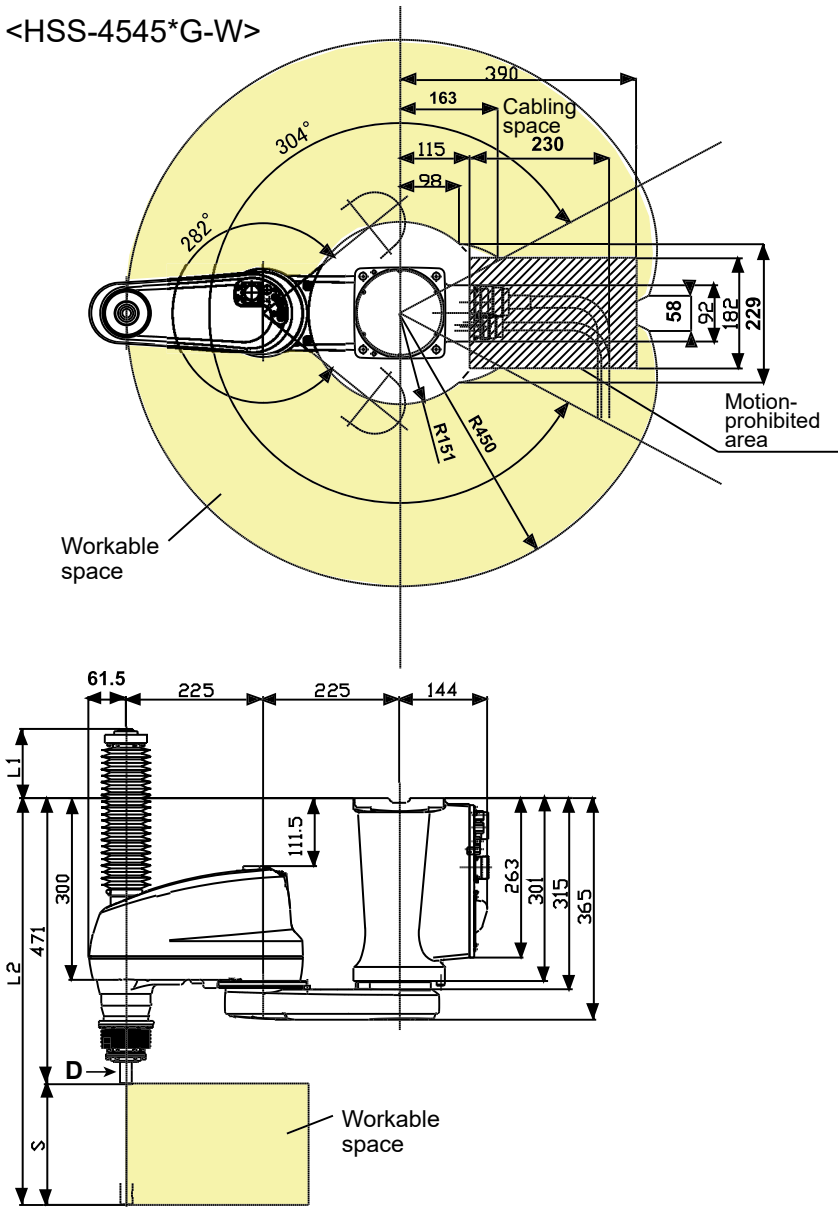

Detailed drawing of hand mounting face (Viewed from D)

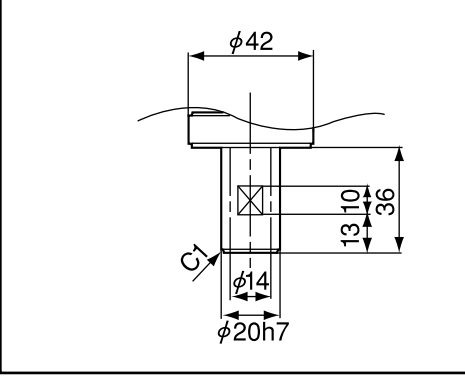

Flange (option) mounting face

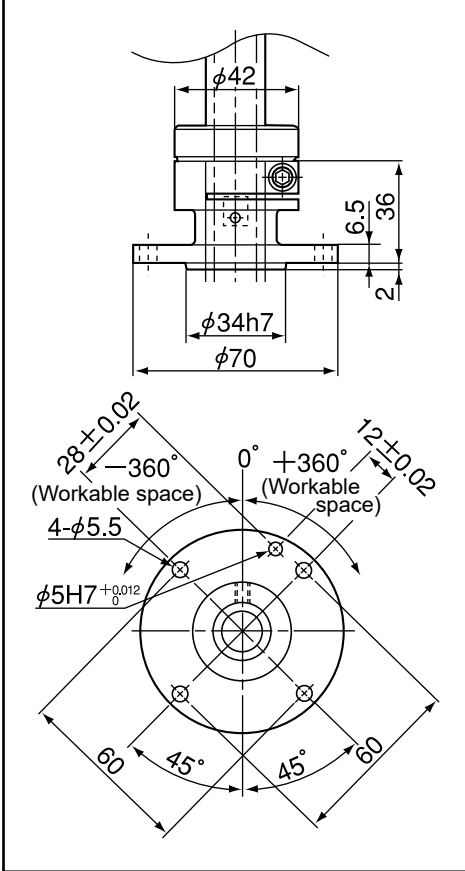

Unit: mm

Base mounting dimensions

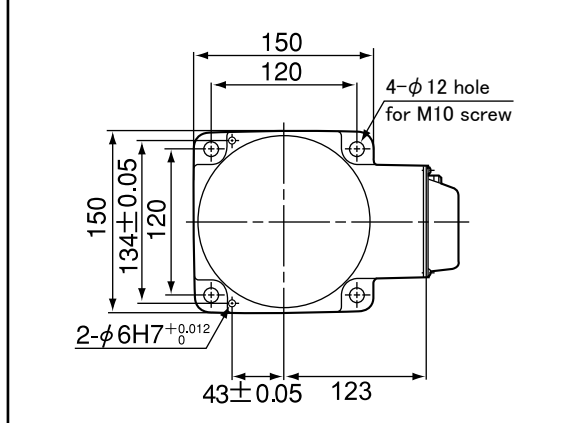

NOTE: Dimensions that differ according to Z-axis stroke (S)

Model	S	L1	L2
HSS-45451G-W	150	64	621
HSS-45452G-W	200	114	671
HSS-45453G-W	320	234	791

NOTE: In the case of the overhead-mount type, the Z axis in the uppermost position may reach higher than the base mounting face. Be careful with the interference with surrounding facilities.