

Mount side

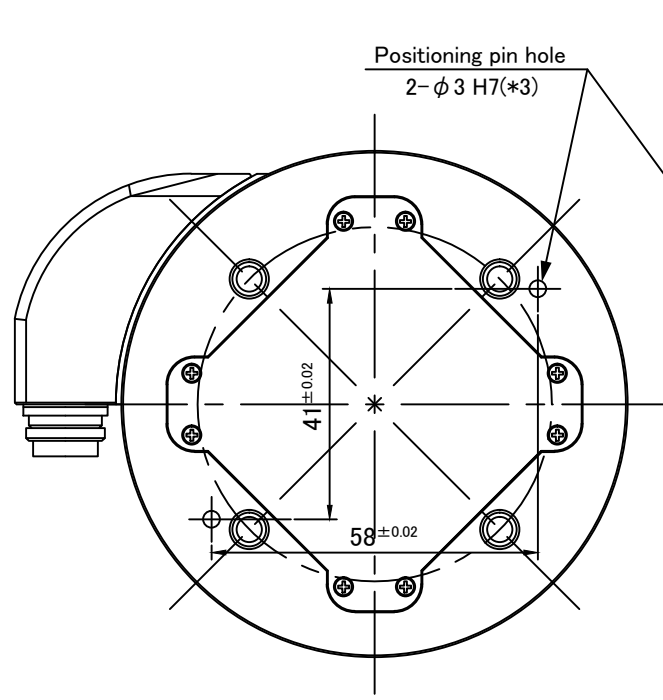

Tool side

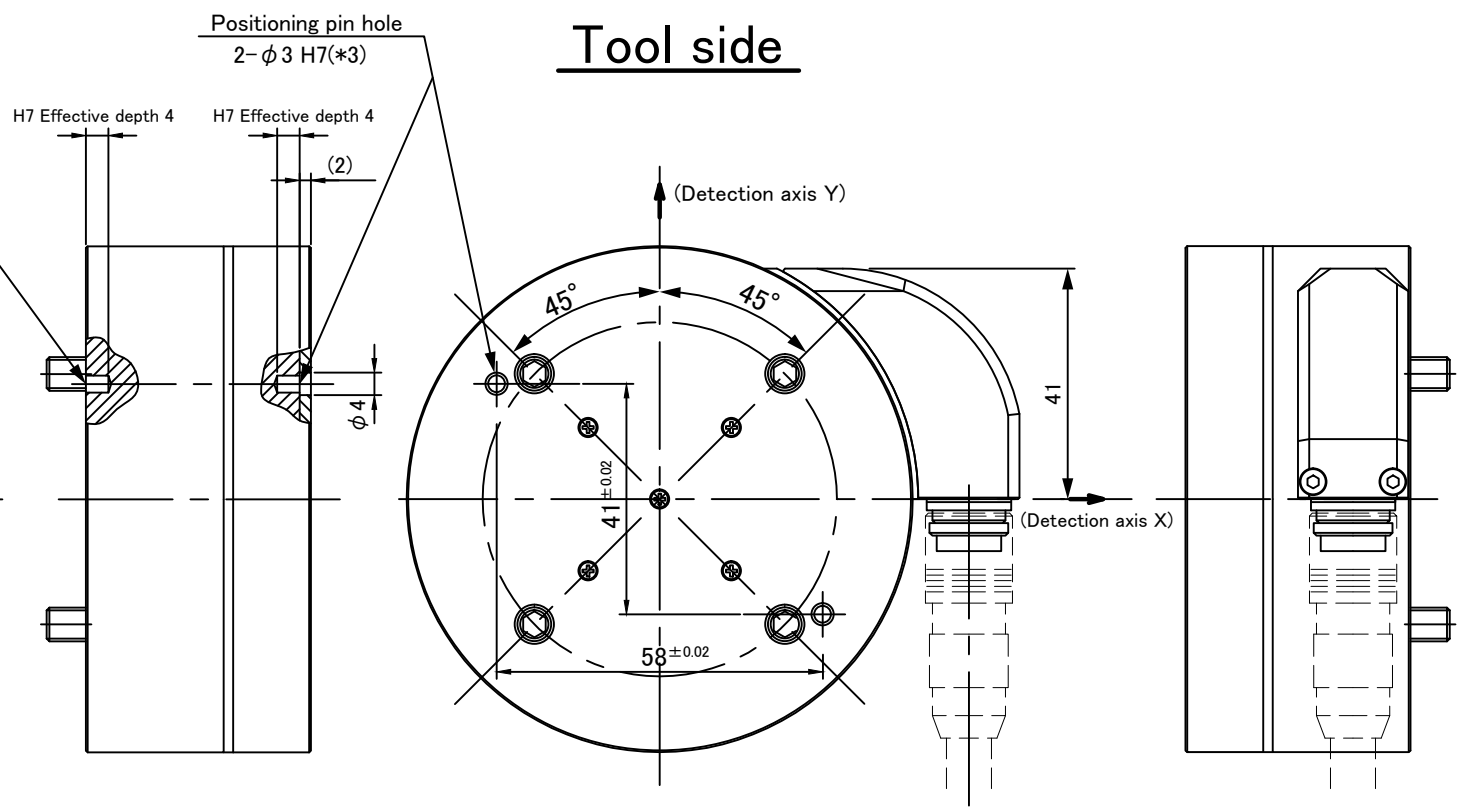

Sensor mounting tapped hole 4-M6 × 1.0
(P.C.D. φ 63) (*1)

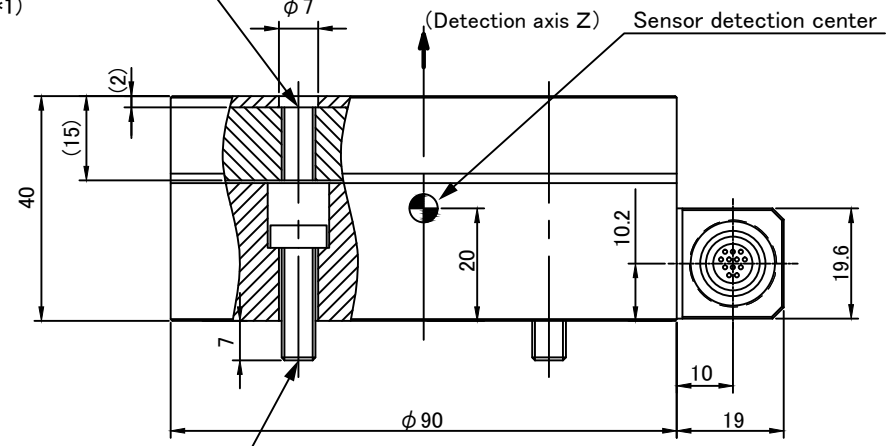

Sensor mounting low head bolt 4-M6 × 1.0
(P.C.D. φ 63) (*2)

- *1 Tool section recommended mounting conditions
 - Bolt strength category: A2-50
 - Tightening torque: 10Nm (±10%)
 - Thread section engagement length: 10~18mm from mounting surface on tool section side (Make sure that engagement length is 18mm or less. If it is exceeded, the sensor may fail.)
- *2 Mount section recommended mounting conditions
 - Tightening torque: 10Nm (±10%)
- *3 Recommended positioning pin
 - Pin dimension: φ 3 g6 Length 9~12mm (Do not insert in excess of H7 effective depth. If it is press-fitted, the sensor may fail.)