

Procedure of Attachment (Reference)

Step 1

Set the feet of the first frame that will be a reference.

- Adjust the height and flatness of the top plate with an adjustment pad.

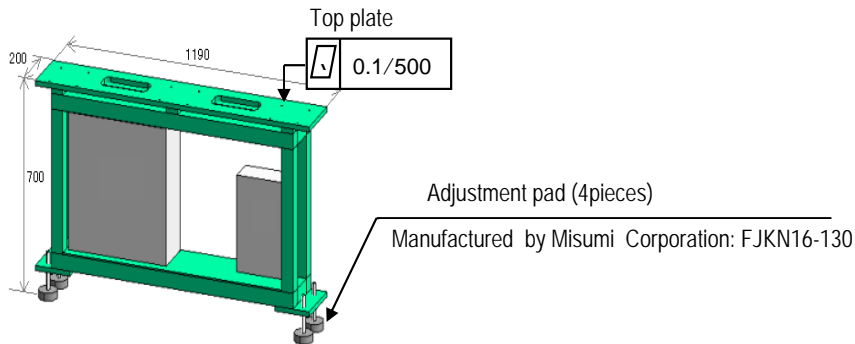

Step 2

Set the feet of the second frame.

- Adjust the height and flatness of the top plate with an adjustment pad.
- Adjust the lateral position, height position, and depth position to those of the first frame  $\pm 4$  mm and the angle to be almost the same.

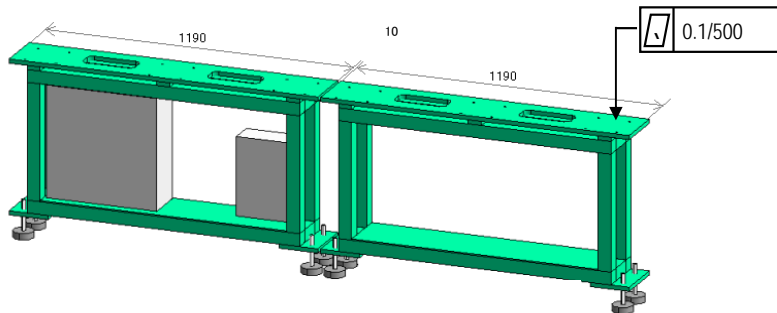

<Direction in depth>

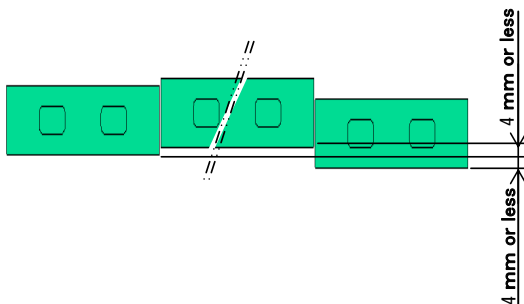

<Direction in height>

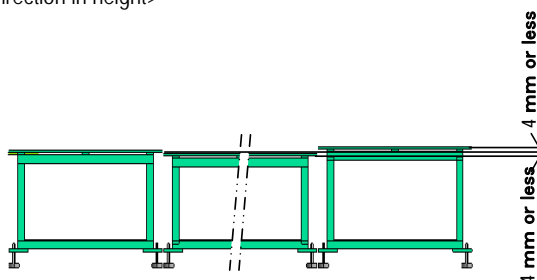

### Step3

Fix the supports of the first frame temporarily.

- Specify the depth position, lateral position, and angle temporarily and tighten with bolts (M8x20) temporarily.

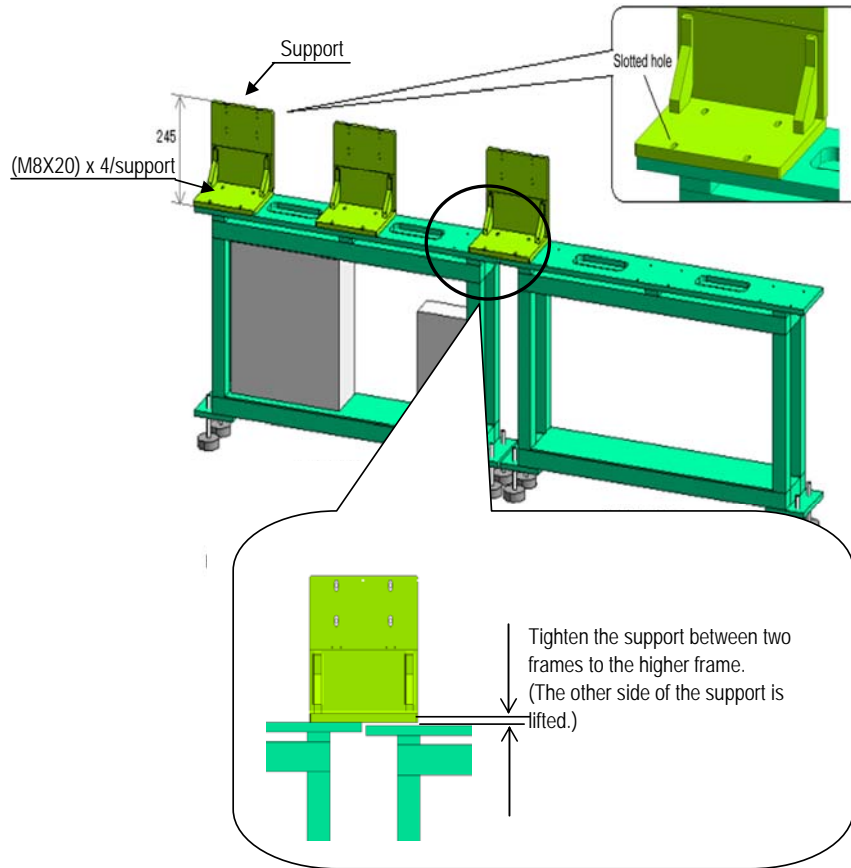

### Step4

Fix the rail unit of the first frame to the supports temporarily, adjust the depth position of the supports to the rail and fix them.

- Adjust the height position, depth position, and angle and fix all the supports of the first frame.

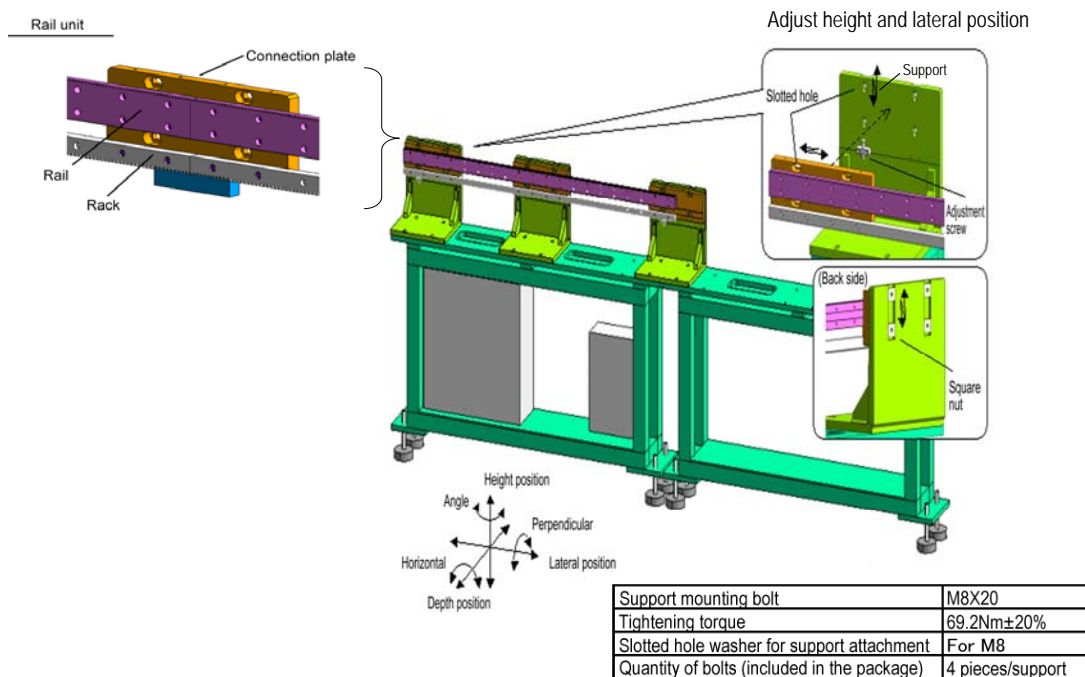

### Step5

Adjust the lateral position of the rail unit of the first frame and fix them.

(Refer to the drawing of Step 4)

### Step6

Set the supports of the second frame temporarily.

- Specify the depth position and the angle temporarily.

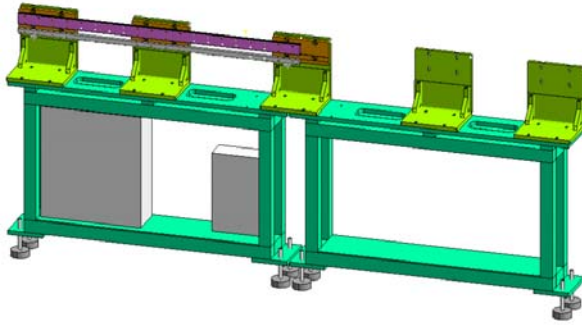

### Step7

Fix the rail unit of the second frame temporarily to the support of the first frame temporarily and fix the supports of the second frame temporarily by adjusting to it.

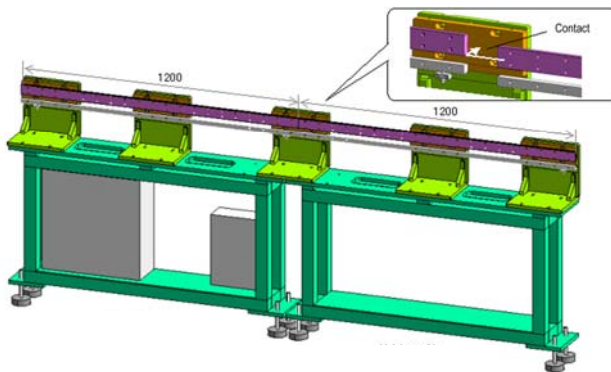

### Step8

Engage the rack gears.

- For engagement of the rack gears, refer to "Pitch Adjustment of Racks."

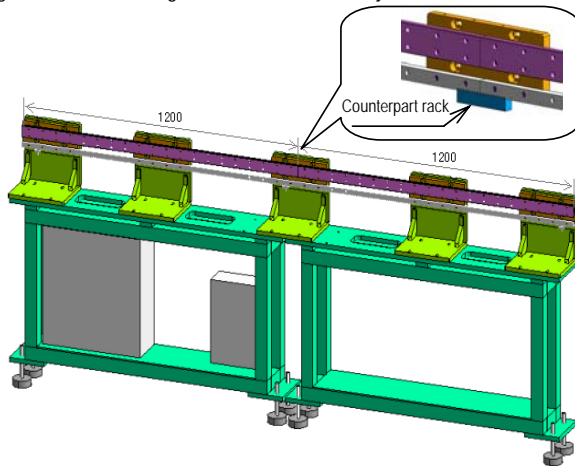

- When the rack gears are engaged, the gap between the rails should be 1mm or less.

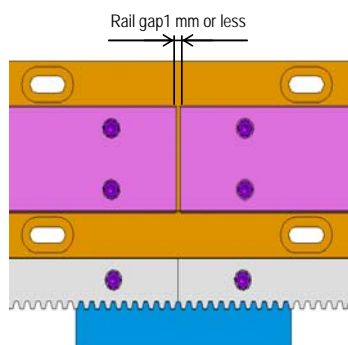

## Step9

### Attachment of rail and rack

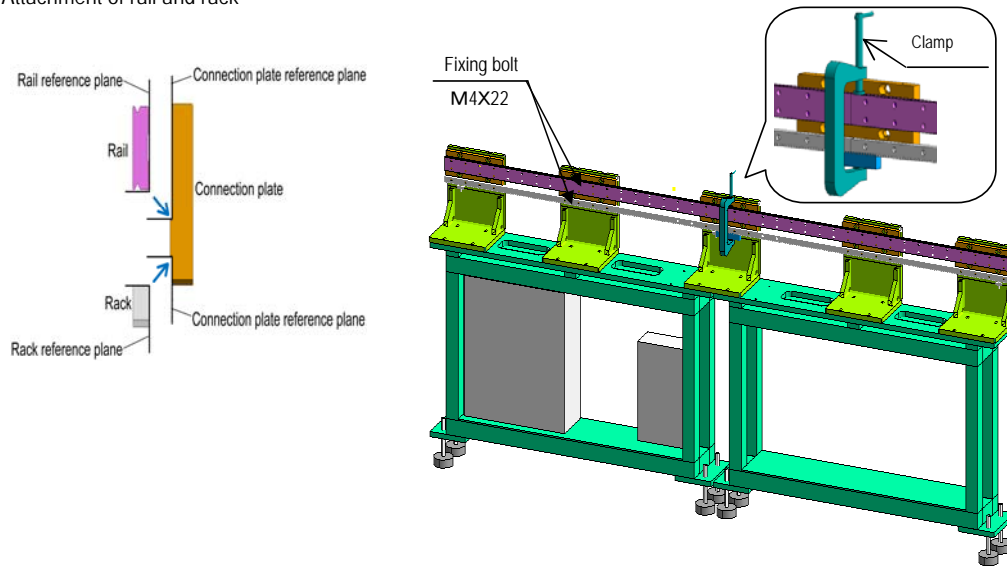

- Adjust the reference planes of the rail and rack to the reference plane of the connection plate and fix them. At that time, make the reference plane of the connection plate contact the reference planes of the rail and rack with small clamps with a clamp force of 2300N or more so that no difference of level is found in the joint of the rails. When clamping, take measures to avoid damage to the rails.

Support mounting bolt	M4X22
Tightening torque	2.9N·m±20%
Quantity of bolts (included in the package)	6 pieces/connection plate

## Step10

Set the rail for the second frame and fix the supports.

- Check the accuracy of rail attachment.

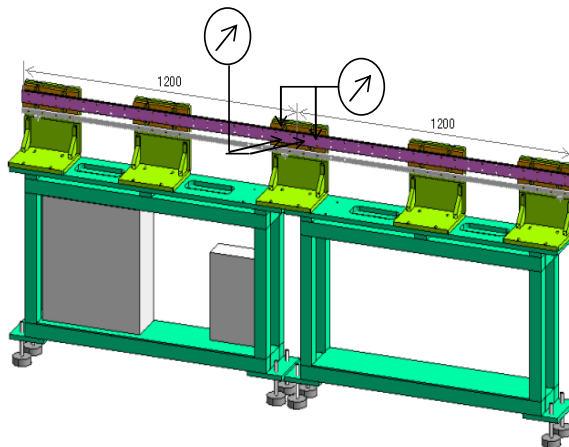

- Fix the supports of the second frame temporarily by adjusting them to the rail of the second frame.
- Check that the parallelism (difference in level) between rails is 0.02 mm or less.
- If it is not 0.02 mm or less, check if trash, burr, etc. are not on the attachment surface. Reassemble the rails and check the parallelism

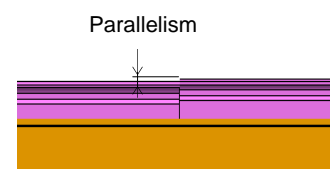
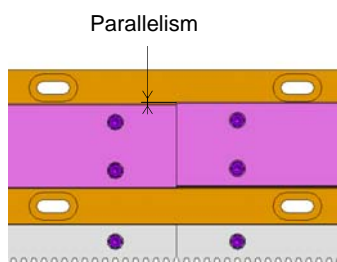

Parallelism of rails (difference in level)  
0.02 mm or less

## Step11

Set the L axis to the rail.

A resin rail is attached to the L axis to prevent the slider ball from falling.



Insert the L axis to the rail with the resin rail attached so that the slider ball of the L axis does not come out.



## Step12

Set the L axis and conduct backlash adjustment.

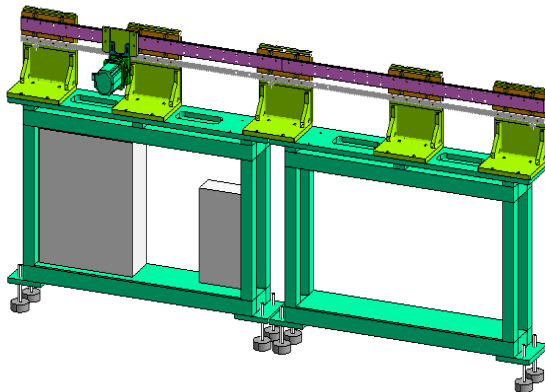

- For backlash adjustment, refer to "Backlash Adjustment."
- After backlash adjustment, check that the sliding friction of the L axis is within the standard (29.4N to 47.1N).  
If the sliding friction is out of the standard, adjust again with the adjustment screw to have the sliding friction within the standard.

### Step 13

Fix stoppers.

- Tighten two stoppers on the both sides of the connection plate.

Stopper tightening bolts  
(M12X50) x 2 pieces/stopper

Stoppers

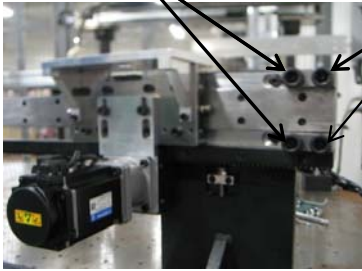

Stopper tightening bolt	M12X50
Tightening torque	42.2Nm±20%
Quantity of bolts	2 pieces/support

### Step 14

Install cableveyor.

- Attach the cableveyor holder to the connection plate of the rail unit and fix it.

Cableveyor mounting bolt	M5X10
Tightening torque	8.8Nm±20%
Quantity of bolts	2

- Attach the cableveyor to the cableveyor holder with bolts and slotted hole washers (for M6) and fix it.

	Cableveyor holder	Slotted hole washer
Mounting bolt	M6X10	M6
Tightening torque	5.3Nm±20%	
Quantity	Bolts, 4 pieces	4 pieces

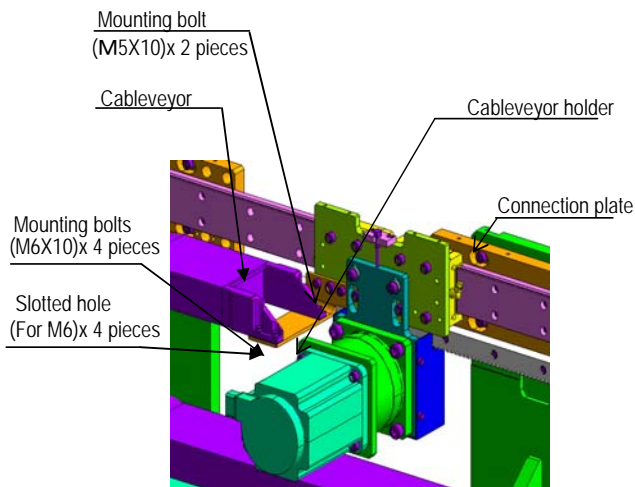

<<Final Form>>

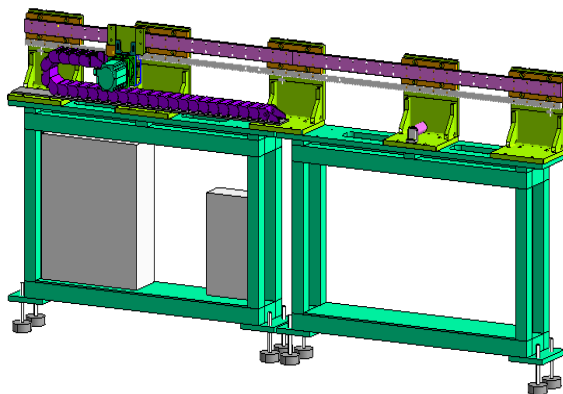

[Cautions for Use of Cableveyor]

The volume of insertion of cable and air piping should be 50 % or less of the capacity inside the cableveyor. Make sure that wiring and piping are properly connected.

The capacity of the cableveyor (TKP0580W50R75) used as a standard is 1900 mm<sup>2</sup>.